

# MSB 18 Safety Brake Datasheet

---

Product Information

Product Data

Product Dimensions



# MSB 18 Safety Brake

## Technical Data

<b>Brake Type</b>	<b>MSB 18</b>
Max TQ (Nm)	130
Weight (g)	1080



Tube Thickness (mm)	Max Suspended Curtain Weight (Kg's)	
60 x 1.5	160	250
70 x 1.5	155	240
89 x 2.0	150	230
101.6 x 3.6	145	210
108 x 3.6	135	200
127 x 4.0	130	180
133 x 4.0	120	170
139.7 x 4.5	115	160
159 x 4.5	110	140

## Essential Product Information

- Activation speed: 22 rpm
- Install with the UP arrow at the 12 o'clock position for proper operation
- Ensure shafts and discs are centered inside the barrel to avoid inadvertent activation
- Prevent slack/tight conditions when using drive sprockets and wheels
- Do not use excessive force to mount the brake onto the shaft
- Operator output torque must not exceed the brake's torque rating
- If fitted with a safety switch, connect it to the STOP circuit of the control panel



## Product Dimensions

Model	A	B	C	D	E	F	G
MSB 18	23	86.3	83.4	8.5	106.5	18	105

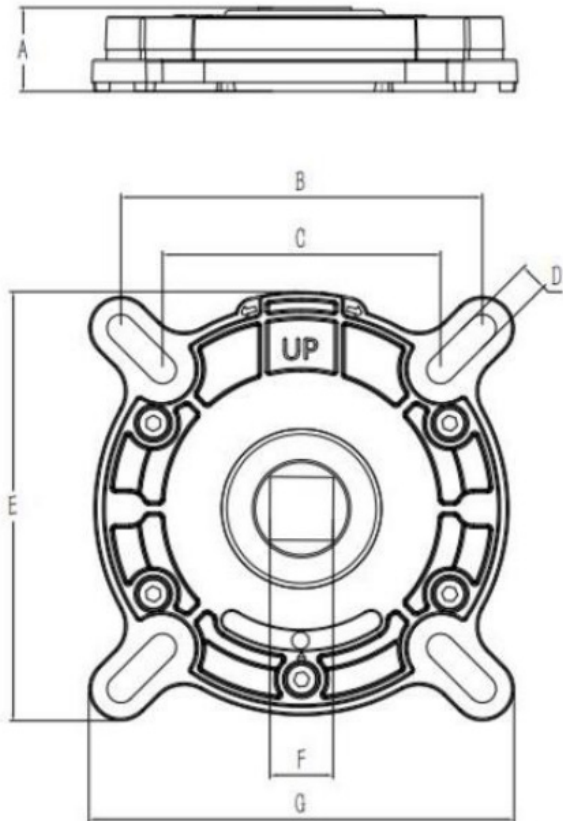

Please Contact Our Sales Department On 01928 579050 For Further Information

