

MOTOR

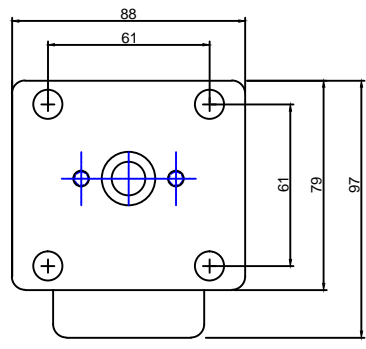

HEAD DETAIL

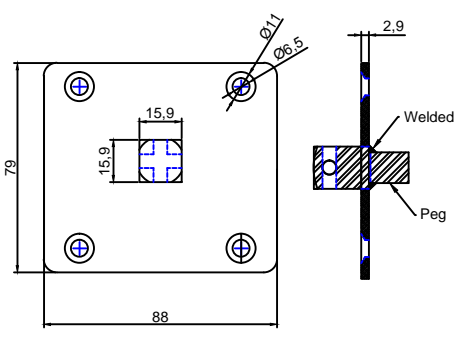

MOUNTING PLATE

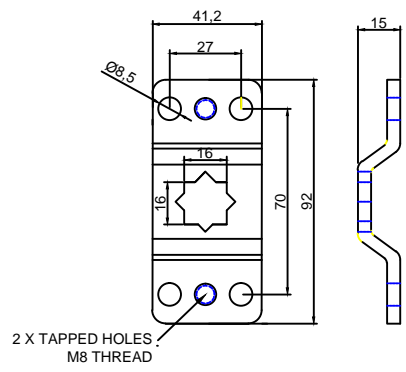

STAR BRACKET

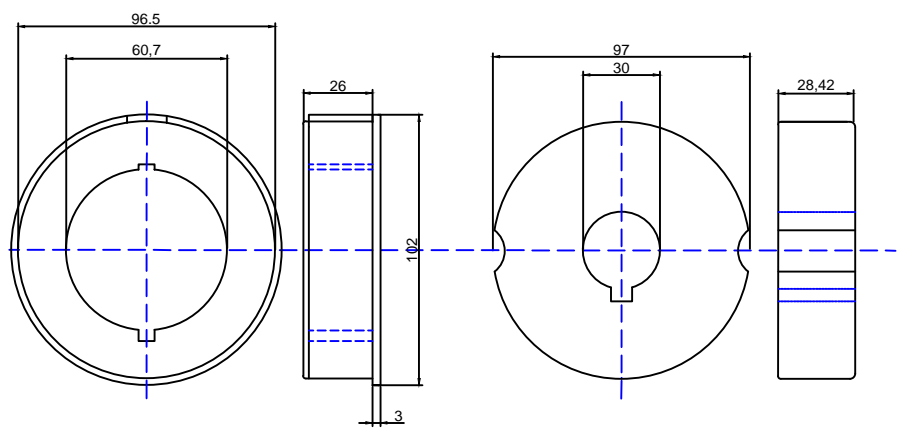

97mm LIMIT ADAPTER (PLASTIC)

97mm DRIVE ADAPTER (ALUMINIUM)

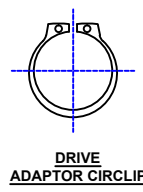

DRIVE ADAPTOR CIRCLIP

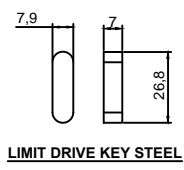

LIMIT DRIVE KEY STEEL

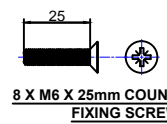

8 X M6 X 25mm COUNTERSUNK FIXING SCREW



8 X M6 NUT

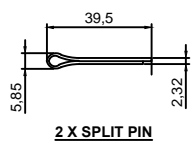

2 X SPLIT PIN

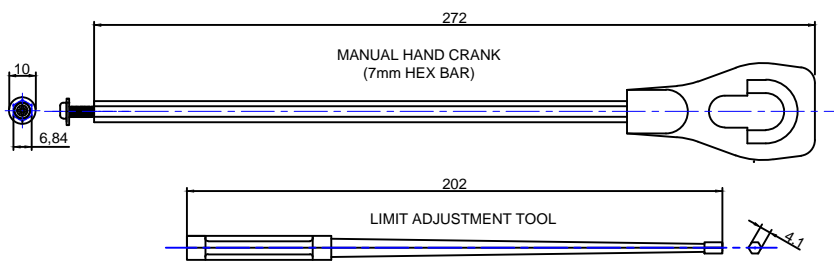

MANUAL HAND CRANK (7mm HEX BAR)

LIMIT ADJUSTMENT TOOL

Specification

Voltage	Hz	Amps	Watts
230V AC	50	1.74	390
Speed	Rating	IP	Limit Turns
10 rpm	4 mins	44	22

marantec
engineered for you

Unit 10 Christleton Court, Manor Park, Runcorn, WA7 1ST

P: +44 (0)1928 579 050
E: info@marantec.co.uk

This drawing is the property of Marantec UK LTD, it may not be reproduced without the written authorization. All intellectual property rights are expressly reserved

Title M1/ 150M TUBE MOTOR GENERAL ARRANGEMENT (97mm ADAPTERS)	Rev/Notes		
	Date 01/11/2021		
	Drawn by DE	Chk'd by 	AP
Drg # 	M1/ 150M General Arr		

Date 01/11/2021		
Drawn by DE	Chk'd by 	AP
Drg # 	M1/ 150M General Arr	