

**Fire Door Control Panel (40-FDCP)
Fire Door Repeater Panel (40-FDR)**

INSTALLATION INSTRUCTIONS



LC-3262 Rev:0

Date: 01/08/2024

Approved By: AP

10 Christleton Court Manor Park, Runcorn Cheshire, WA7 1TS

technical@marantec.co.uk

www.marantec.co.uk

Contents

1 - Specification Dimensions and Installation.

2 - Board Layout.

3 - Programming - DIP Switches and Auto Close Timer.

4 - Connections.

4.1 - Power Supply.

4.2 - Motor.

4.3 - Fire Signal.

4.4 - Photocell.

4.5 - Single Impulse Button.

4.6 - Stop Button and Safety Brake.

4.7 - Key-switch and Push Button.

4.8 - Aux Relay.

4.9 - Emergency Re-Open.

5 - Status Indication and troubleshooting.

6 - Repeater Panel Connection.

7 - Commissioning.

Multi Function Fire Control System for Roller Shutters

Features

- Visual warning 'FIRE SHUTTER OPERATING' and 98 dB sounder
- Easy to program using internal DIP Switches
- Selectable fire signal using - Normally Open (N/O) or Normally Closed (N/C) volt free contact
- Connection for Low Voltage external controls by key-switch or push button operation
- Door Closing method by - Mains Power only
- Programmable Auxiliary relay
- LED Fault diagnostics
- Audio / Visual Delay Timer from 0 - 5mins
- Extended door close timer using a Cyclic Pulse and Pause operation from 0 - 15 secs
- Repeater extension panel available for remote indication
- Motor stop and reverse safety possible by use of additional safety devices (not supplied)
- Front panel multi-functional RED indicator
- Auto close function

General Application

- The FDCP is designed to operate roller doors fitted with a 230v tubular motor type drives
- While maintaining the function of every day normal use, the FDCP gives advanced warning in the event of a fire before closing the door, protecting both personnel and property from the effects of smoke and fire
- The control system and all its features can be programmed to meet most site requirements, to automatically close the door upon receiving a fire signal

Installation

- This product is designed for indoor use only and should be installed in a dry area not exceeding its temperature specification
- The enclosure should be mounted vertically and secured using the provided fixing holes
- It should be mounted in a suitable position, within sight of the door and un-obscured
- Consideration must be given to the incoming cables and the panel rotated accordingly to give top or bottom cable entry
- Mains Power should be provided from an adjacent 230V 13A fused spur connection
- It is recommended that the panel be fitted at a height of 1.6m or above and be visible from all directions
- This product must be connected to a suitable **EARTH** point, to protect both motor and personnel
- All electrical work should be undertaken by a competent person.
- This product must be installed in accordance with all relevant standards & regulations.

1 - Specification, Dimensions and Installation

Power Supply	230v - 50Hz
Max Motor Load	2.4A @ 230v or 500Watts
Max Accessories Load	150mA @ 24v d.c
Working Temp	-15 to +55°C
Protection Fuses	Mains: F1 = T6.3A, Delayed Ext 24v d.c: F2 = T250mA, Delayed
Sounder	98 dB (Decibels)
Enclosure Rating	IP 20
Dimensions (mm)	180 (w) x 180 (h) x 65 (h)
Weight (g)	300

Mount the unit using the fixing holes provided

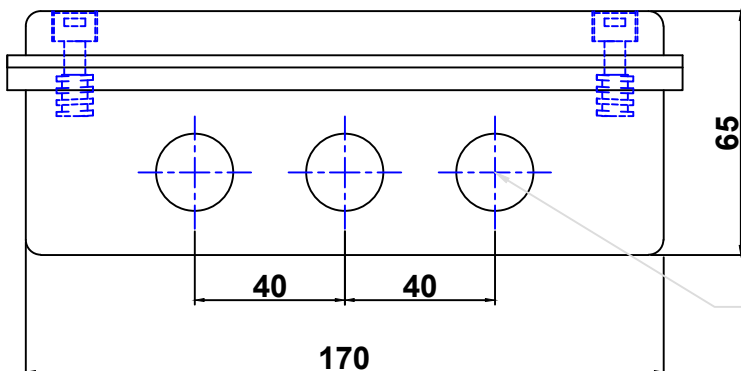
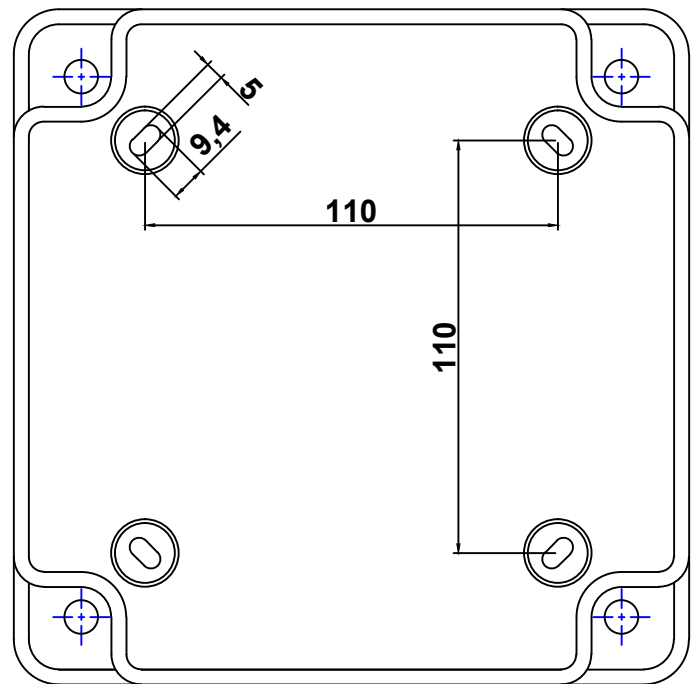
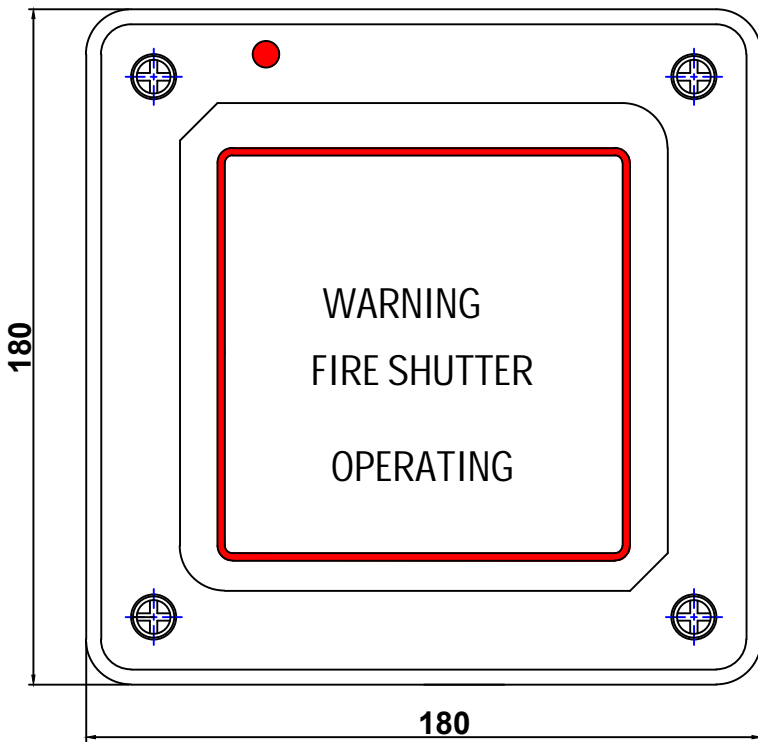

3 x 20mm Knockouts

2 - Board Layout

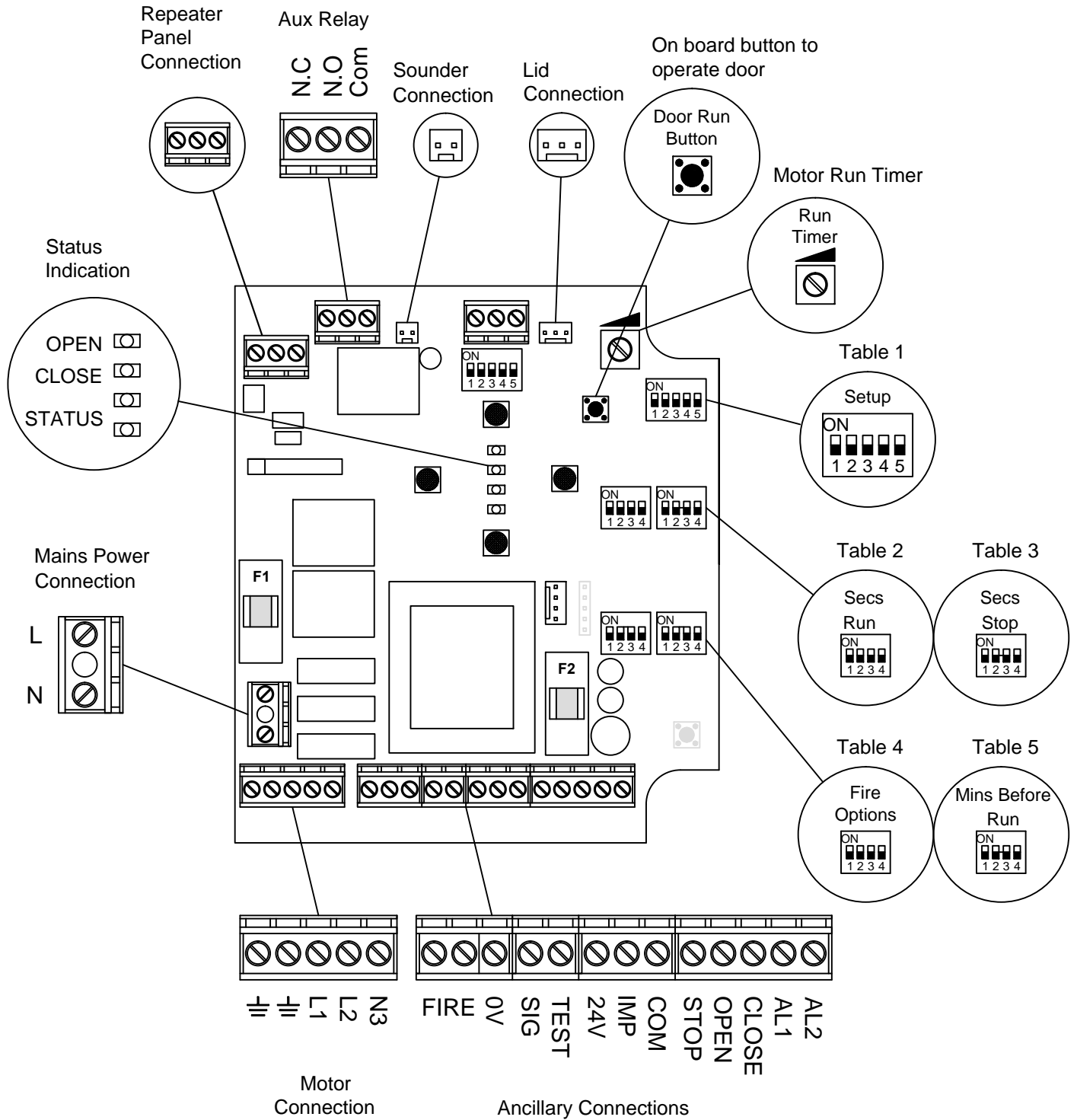

3 - Programming The Fire Shutter Control Settings

To suit most site requirements the FDCP control panel can be programmed to close or open a door in the event of fire using a selection of various DIP Switch settings

DIP	Table 1 - Setup		Notes
1 <i>(see note)</i>	Off	No Function	
	On	Aux relay pulses 3 times before door movement	**Needs DIP 3 - on (FIRE OPTIONS)
2	Off	Door retracts fully after safety device activated	
	On	Door partial retracts 200mm after safety device activated	
3	Off	Motor power is applied for the full duration of run timer	
	On	No Function	
4	Off	Auto Close feature turned off	
	On	Auto Close feature turned on (requires safety device)	
5	Off	Motor current sensing turned on	
	On	Motor current sensing turned off	

Setting a pulse and pause Motor drive on closure

It is possible to extend the overall closure time by setting the "pulse" and "pause" drive option
 Set the DIP Switches in accordance with the tables opposite
 Upon activation from a fire signal the door will begin closing then pausing, this will repeat until the door is fully closed
 Using the control system in this way could for instance, provide extra time for people to exit the building in a fire situation

Table 2 - Run				
DIP Switch				
1	2	3	4	
Off	Off	Off	Off	Not Active
On	Off	Off	Off	1 sec
Off	On	Off	Off	2 sec
On	On	Off	Off	3 sec
Off	Off	On	Off	4 sec
On	Off	On	Off	5 sec
Off	On	On	Off	6 sec
On	On	On	Off	7 sec
Off	Off	Off	On	8 sec
On	Off	Off	On	9 sec
Off	On	Off	On	10 sec
On	On	Off	On	11 sec
Off	Off	On	On	12 sec
On	Off	On	On	13 sec
Off	On	On	On	14 sec
On	On	On	On	15 sec

Table 3 - Stop				
DIP Switch				
1	2	3	4	
Off	Off	Off	Off	Not Active
On	Off	Off	Off	1 sec
Off	On	Off	Off	2 sec
On	On	Off	Off	3 sec
Off	Off	On	Off	4 sec
On	Off	On	Off	5 sec
Off	On	On	Off	6 sec
On	On	On	Off	7 sec
Off	Off	Off	On	8 sec
On	Off	Off	On	9 sec
Off	On	Off	On	10 sec
On	On	Off	On	11 sec
Off	Off	On	On	12 sec
On	Off	On	On	13 sec
Off	On	On	On	14 sec
On	On	On	On	15 sec

DIP	Table 4 - Fire Options		Notes
1	Off	Door CLOSES on fire alarm	
	On	Door OPENS on fire Alarm	
2	Off	Panel requires a N.O Fire alarm signal to activate	
	On	Panel requires a N.C Fire alarm signal to activate	
3 <i>(see note)</i>	Off	Aux relay operates for the same time as the alarm signal	<i>**Function Only active in fire</i>
	On	Aux relay latches for 3.5 mins in normal operation	<i>**Function only active in normal operation, DIP 3 = off (FIRE OPTIONS)</i>
4	Off	Not used	
	On	Not used	

Setting a Delay Time before closure on receipt of fire signal

A signal from the fire alarm will immediately activate the FDCP visual and audible warnings

By setting a combination of DIP Switches from the table opposite, a delay time will be entered to give audio / visual warning before closure of the shutter begins

Table 5 - Mins Before Run				
DIP Switch				Delay Time
1	2	3	4	
Off	Off	Off	Off	Immediate Close
On	Off	Off	Off	20 sec
Off	On	Off	Off	40 sec
On	On	Off	Off	1 min
Off	Off	On	Off	1 min 20 secs
On	Off	On	Off	1 min 40 secs
Off	On	On	Off	2 mins
On	On	On	Off	2 mins 20 sec
Off	Off	Off	On	2 mins 40 sec
On	Off	Off	On	3 mins
Off	On	Off	On	3 mins 20 secs
On	On	Off	On	3 mins 40 secs
Off	Off	On	On	4 mins
On	Off	On	On	4 mins 20 secs
Off	On	On	On	4 mins 40 secs
On	On	On	On	5 mins

Setting an Auto Delay Time

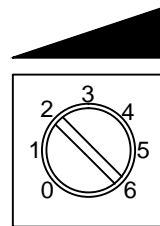

By setting the dial in the chosen position, the FCP-01 will pre load both the motor run timer and the optimum auto close delay time (requires photocell connected and DIP 4 = **ON**, Table - SETUP)

Dial Position	Motor run Time (Secs)	Auto Close Delay Time (Secs)
0	2	10
1	8	18
2	16	34
3	26	46
4	35	60
5	44	70
6	52	90

Important

When using auto-close function, set run time slightly longer than door travel time
The motor must reach its top limit for the auto-close to activate

4.1 Power Supply Connection

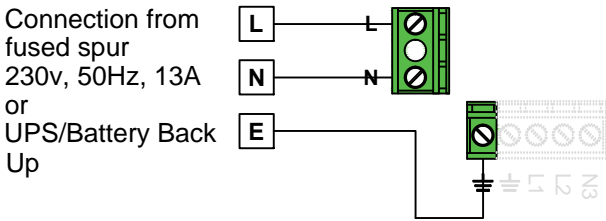

4.2 Motor Connection

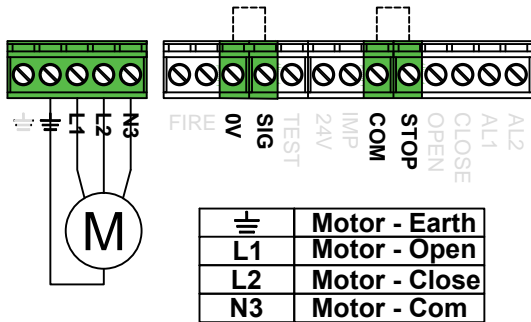

When operating check the motor direction matches the corresponding LED indication on the panel. Reverse the connections L1 + L2 to correct motor direction if necessary

4.3 Fire Signal Connection

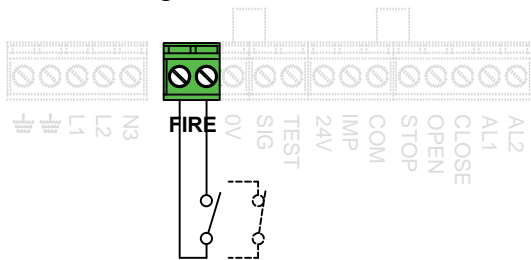

To activate the panel connect a N.O or N.C fire signal (see Table 4, DIP SW 2 for options)

4.4 Safety Device / Photocell Connection

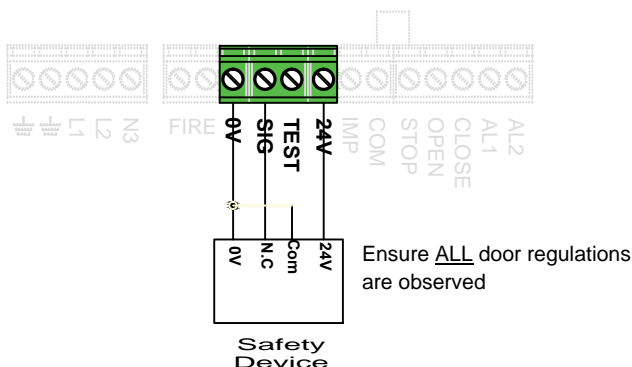

4.5 Single Impulse Button Connection

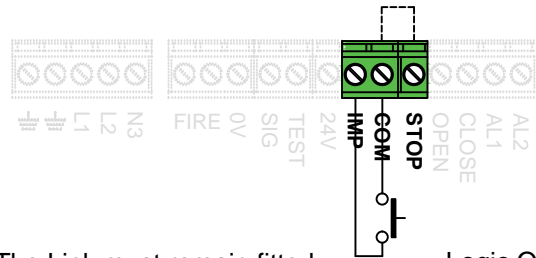

The Link must remain fitted between STOP and COM

Logic Operation
OPEN-STOP-CLOSE
-STOP

4.6 Stop Button or Safety Brake Connection

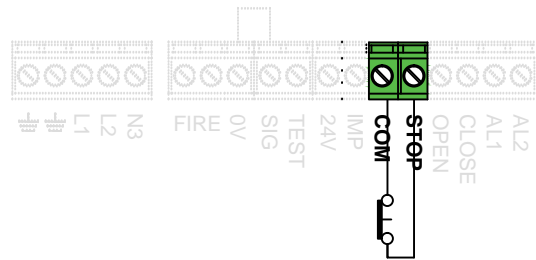

4.7 Key-switch / Push Button Connection

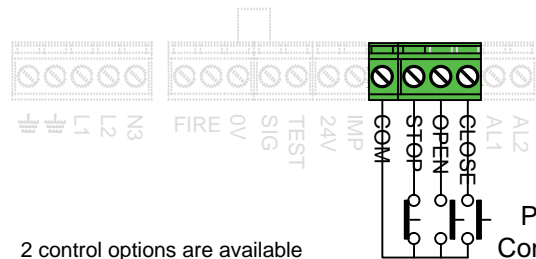
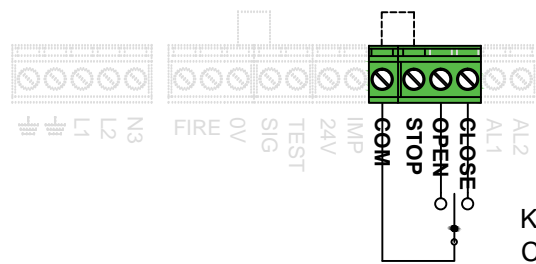

2 control options are available

- Impulse OPEN / CLOSE
This requires both safety links to be fitted, momentary activation of the key switch will cause the door to open or close
- Impulse OPEN / Hold to Run (Dead-man) - CLOSE
Remove Safety Link from (0v and SIG)

4.8 Aux Relay

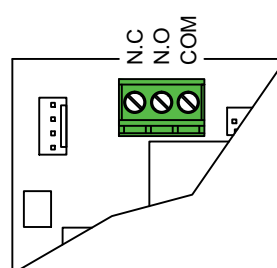

Refer to:
Table - Fire Options - DIP Sw3

Note: - Only active on fire signal

4.9 Emergency Re-Open Connection

5 - Status Indication and trouble shooting

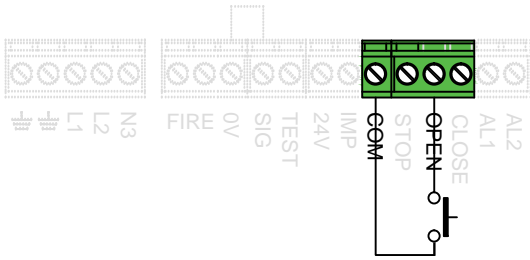

A non latching open command can be used to re-open the door when a fire signal is active. Command is dead-man, once released the door immediately closes.

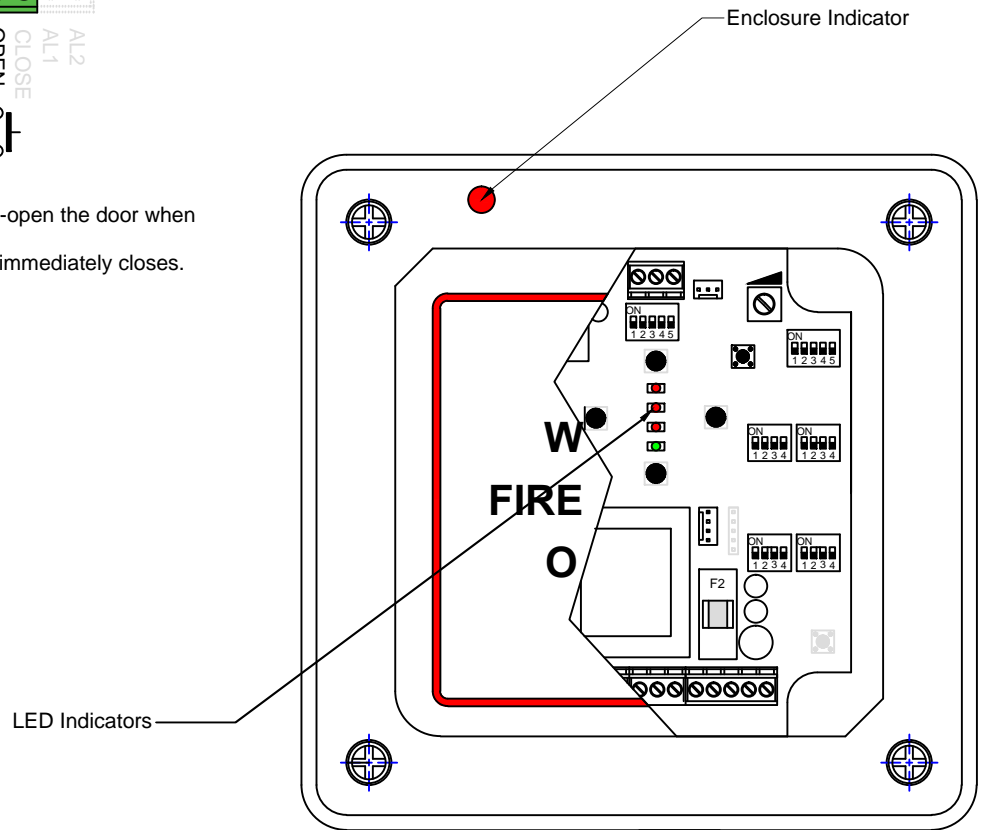

NOTE:

Enclosure Indicator can be disconnected with zero detriment to control panel operation if required.

		LED	Table 4 - Fire Options
OPEN <input type="checkbox"/> CLOSE <input type="checkbox"/> STATUS <input type="checkbox"/>	Open	Off	No Motor Action
		RED	Motor operating - Open Direction
		<u>RED</u> then drops out after 1 sec	Check motor connection - Open Direction or Motor faulty
	Close	Off	No Motor Action
		RED	Motor operating - Close Direction
		<u>RED</u> then drops out after 1 sec	Check motor connection - Close Direction Motor direction faulty
Status	GREEN	Power Available	
	GREEN = off RED = on	Stop fault - check link (Com / Stop) or stop button	
Enclosure Lid LED		Off	No Power supply or in fire alarm condition
		Solid RED	Power ON - Safety Device Connected
		Flashing RED	Power ON - Dead-Man closing only

6 - Connection of FDCP to FDR (Repeater Panel)

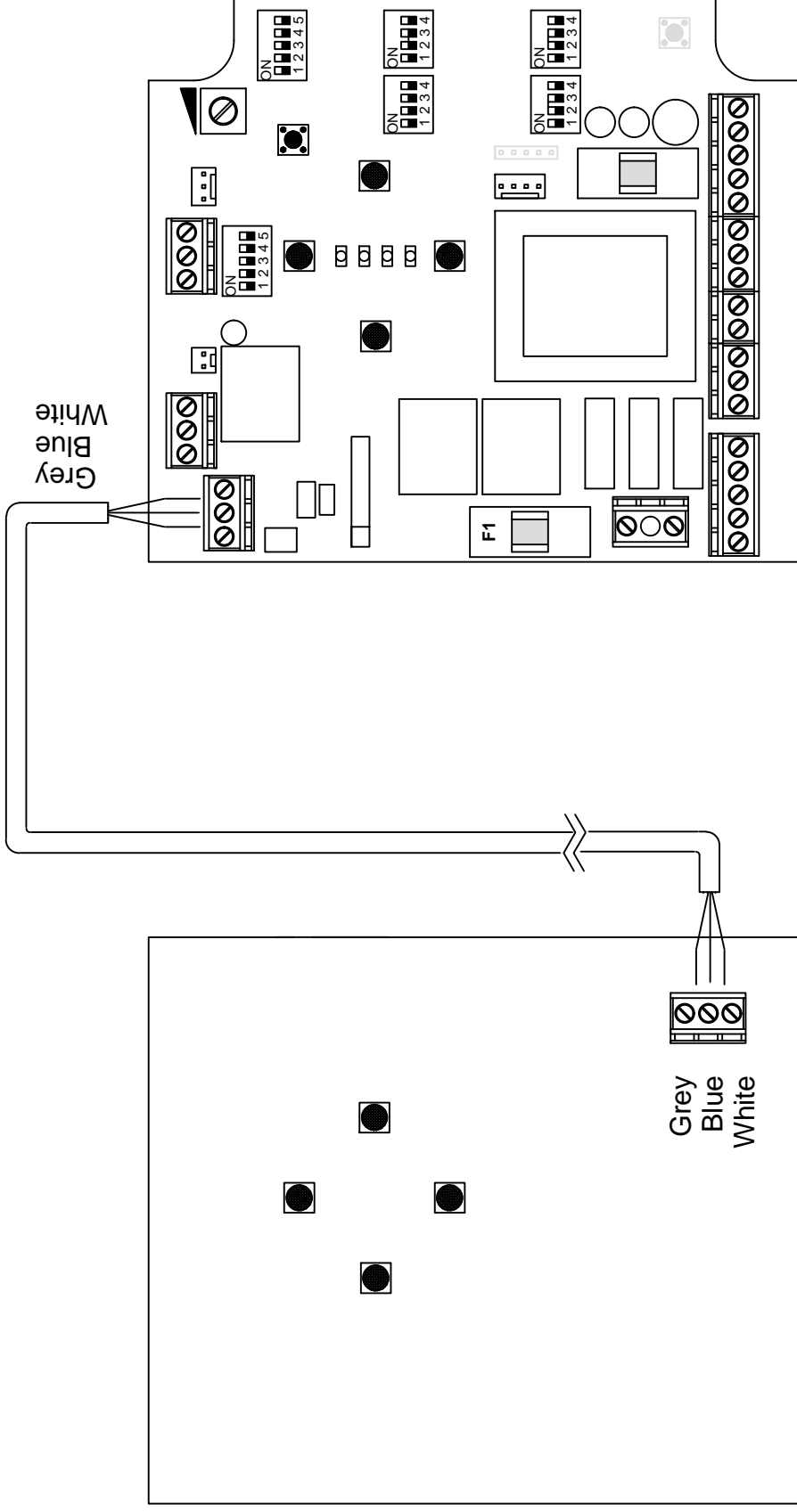

FDR - Repeater Panel

FDCP - Control Panel

7 - Commissioning

- Connect all required devices e.g motor, key-switch (photocell optional)
- If no safety device is used ensure link is removed between 0v and SIG
- If a key switch is used ensure link is fitted between COM and STOP
- Turn Run Time Dial fully clockwise to give max run time (52 secs)
- Apply Power
- Before setting the travel limits, turn the motor current sensing OFF by Moving DIP SW 5 (Table 1 - SETUP) to ON position
- Operate the door and set travel limits at desired positions
- Check by running the door to full open position, then full closed position, adjust if necessary
- Move DIP SW 5 (Table 1 - SETUP) back to OFF position
- If auto close is required move DIP SW 4 (Table 1 - SETUP) to ON position
- Operate door again and check photocell in the closing direction for stop and retract (options set by DIP2, Table 1 - SETUP)
- If no photocell is fitted, remove the link between (0v and SIG) to give Hold-to-run control (Dead man) in the close direction

Please note: In Hold-to-Run (Dead man) mode there is a slight delay when operating in the close direction

Fire Signal

- Select the fire signal type to be used using DIP SW 2 (Table 4 - FIRE OPTIONS) and connect a volt free signal to the terminals marked "FIRE"
- Set the delay time required using the DIP Switches as in "Table 5 - DELAY TIMER"
- Open the door fully and using a simulated fire signal, activate the panel
The panel will give an audio/visual warning for the delay time set, then begin to close the door

The door will continue to close run for as long as the simulated signal remains on



marantec 
engineered for you

Certificate of Conformity

Certificate No. : STL2024S 1112083C-Y1
Applicant : Marantec UK Limited
Address : Unit 10 Christelton Court, Runcorn, Cheshire, WA7 1ST
Manufacturer : Marantec UK Limited
Address : Unit 10 Christelton Court, Runcorn, Cheshire, WA7 1ST
Product : Marantec FDCP
Trade Name : Marantec
Model : FDCP
Test Standards : EN 60335-1:2012+A11:2014+A13:2017 + A1:2019 + A2:2019 +
A14:2019 + A15:2021 + A16:2023
EN IEC 60335-2-103:2023 + A2:2023
EN 62233: 2008

The EUT described above has been tested by us with the listed standards and found in compliance with the council LVD directive 2014/35/EU. It is possible to use CE marking to demonstrate the compliance with this LVD directive.



Marantec UK Ltd.

Unit 10 Christleton Court, Manor Park, Runcorn, Cheshire, WA7 1ST

Tel: 01928 579 050 | Email: sales@marantec.co.uk | www.marantec.co.uk



marantec 
engineered for you

Certificate of Conformity

Certificate No. : STL2024S 1112083C-Y1
Applicant : Marantec UK Limited
Address : Unit 10 Christelton Court, Runcorn, Cheshire, WA7 1ST
Manufacturer : Marantec UK Limited
Address : Unit 10 Christelton Court, Runcorn, Cheshire, WA7 1ST
Product Name : Marantec FDCP
Trade Name : Marantec
Model : FDCP
Test Standards : BS EN 60335-1:2012 + A11:2014 + A13:2017 + A1:2019 +
A14:2019 + A15:2021 + A16:2023
BS EN IEC 60335-2-103:2023 + A2:2023
BS EN 62233: 2008

The certificate of conformity is based on an evaluation of a sample of the above-mentioned product. This Attestation of Compliance is issued according to the Great Britain legislation Electrical Equipment (Safety) Regulations 2016. It confirms that the listed product complies with all essential requirements of the Regulations. The applicant is authorized to use this certificate in connection with UK Declaration of Conformity.

**UK
CA**



Marantec UK Ltd.

Unit 10 Christleton Court, Manor Park, Runcorn, Cheshire, WA7 1ST

Tel: 01928 579 050 | Email: sales@marantec.co.uk | www.marantec.co.uk