

## Control Panel Layout & Dimensions

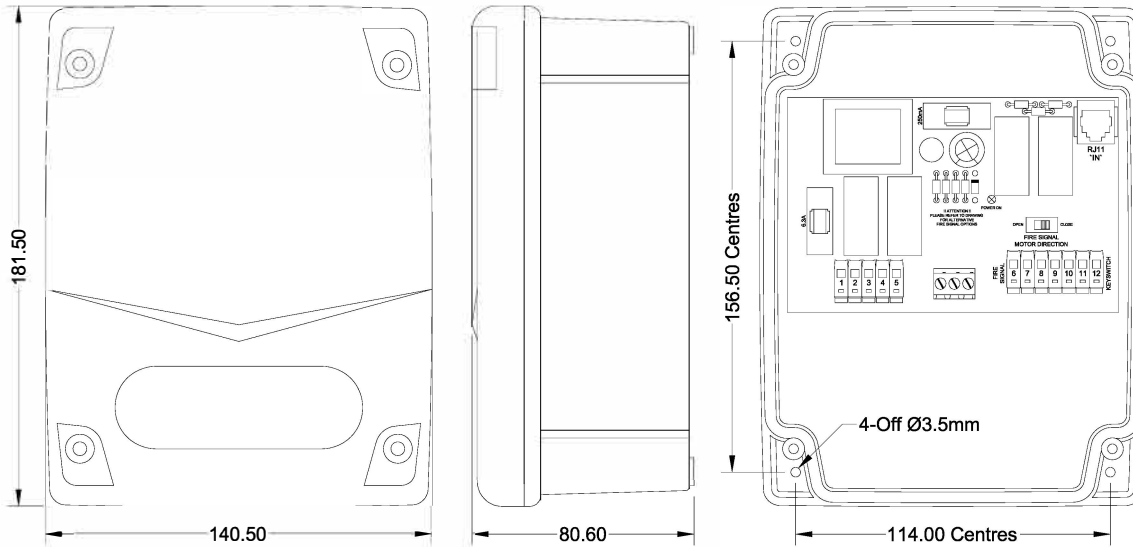

### Operation as a Simple Tube Motor Controller

1. The door will open & close via the keyswitch in Deadman mode (i.e. Hold-to-Run).
2. If the door travels in the wrong direction, simply swap the black & brown motor wires around.

### Operation as a Simple Fire Door Interface

1. The door will open & close via the keyswitch in Deadman mode (i.e. Hold-to-Run).
2. If the door travels in the wrong direction, simply swap the black & brown motor wires around.
3. Upon receipt of either a volt-free or a 24VDC fire signal, the door will travel in the selected direction. The door will be inoperable until the fire signal is removed.
4. If the door travels in the wrong direction upon receipt of a fire signal then simply change the direction via the 'fire signal direction switch'.

### Operation with UPS (Battery Back-up)

1. Connect the mains in lead from the UPS into a suitable fused spur or socket that is **always** on.
2. Connect from a 230VAC power outlet (socket) on the rear of the UPS to terminals 'L', 'N' & 'E'.
3. Plug in the RJ11 lead provided with the UPS into the RJ11 'IN' socket in the top right of the board and the other end into the RJ11 'IN' socket on the rear of the UPS.
4. Ensure the UPS mains ON/OFF switch is set to the 'OFF' position for 'sleep' mode

In 'sleep' mode the UPS will be turned off and only become 'live' when a command is given to the FDI-UPS controller. This will ensure that the UPS can provide the maximum standby time by using power only when required. This will allow a fully charged UPS to provide a supply for several days after a power failure. When the mains supply is healthy the UPS will become 'live' almost immediately and power the motor. If a power failure occurs, there will be a delay of approx. 3 seconds for the UPS to fully 'wake up' before the motor will run. This 3 second delay also acts as a warning that there may be a problem with the mains supply to the UPS.

## Terminal Connections

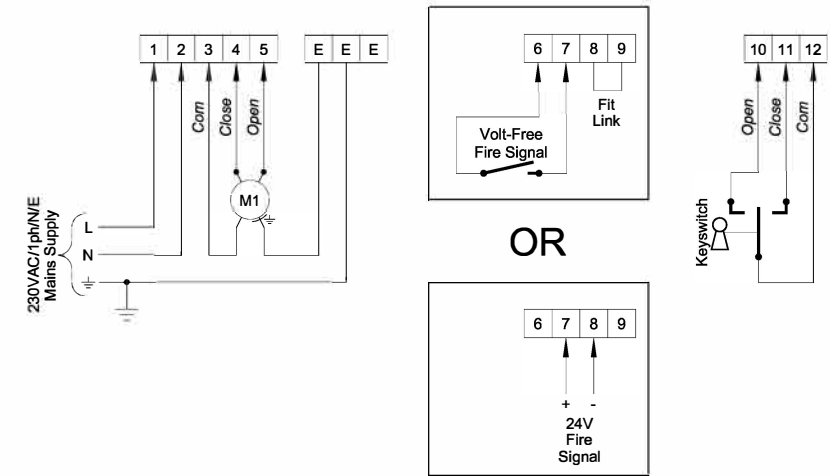

1. Power Supply: Connect a 230VAC supply to terminals as shown.
2. Tube Motor: Connect a 230VAC tube motor as shown (max 1000W).
3. Keyswitch: Connect a keyswitch to the terminals as shown.
4. Volt-free Fire Signal: Connect a N/O volt-free fire signal to terminals '6' & '7' and fit a link between terminals '8' & '9'.
5. 24VDC Fire Signal: Connect a 24VDC fire signal to terminals '7' & '8' as shown (no link fitted).
6. UPS connection: (If Required) Plug in the RJ11 lead provided with the UPS into the RJ11 'IN' socket in the top right of the board and the other end into the RJ11 'IN' socket on the rear of the UPS.

### Note:-

The Keyswitch and Fire Signal terminals are all at a safer low voltage of 24VDC and **DO NOT** carry any mains voltage.

### IMPORTANT:

The 'Sleep Mode' is only available if used with the Marantec UK Ltd UPS range via the RJ11 connection.