

AE0900 Installation Instructions

WARNING! Read these instructions **FULLY** before use.
Installation should only be carried out by a **COMPETENT** installer.

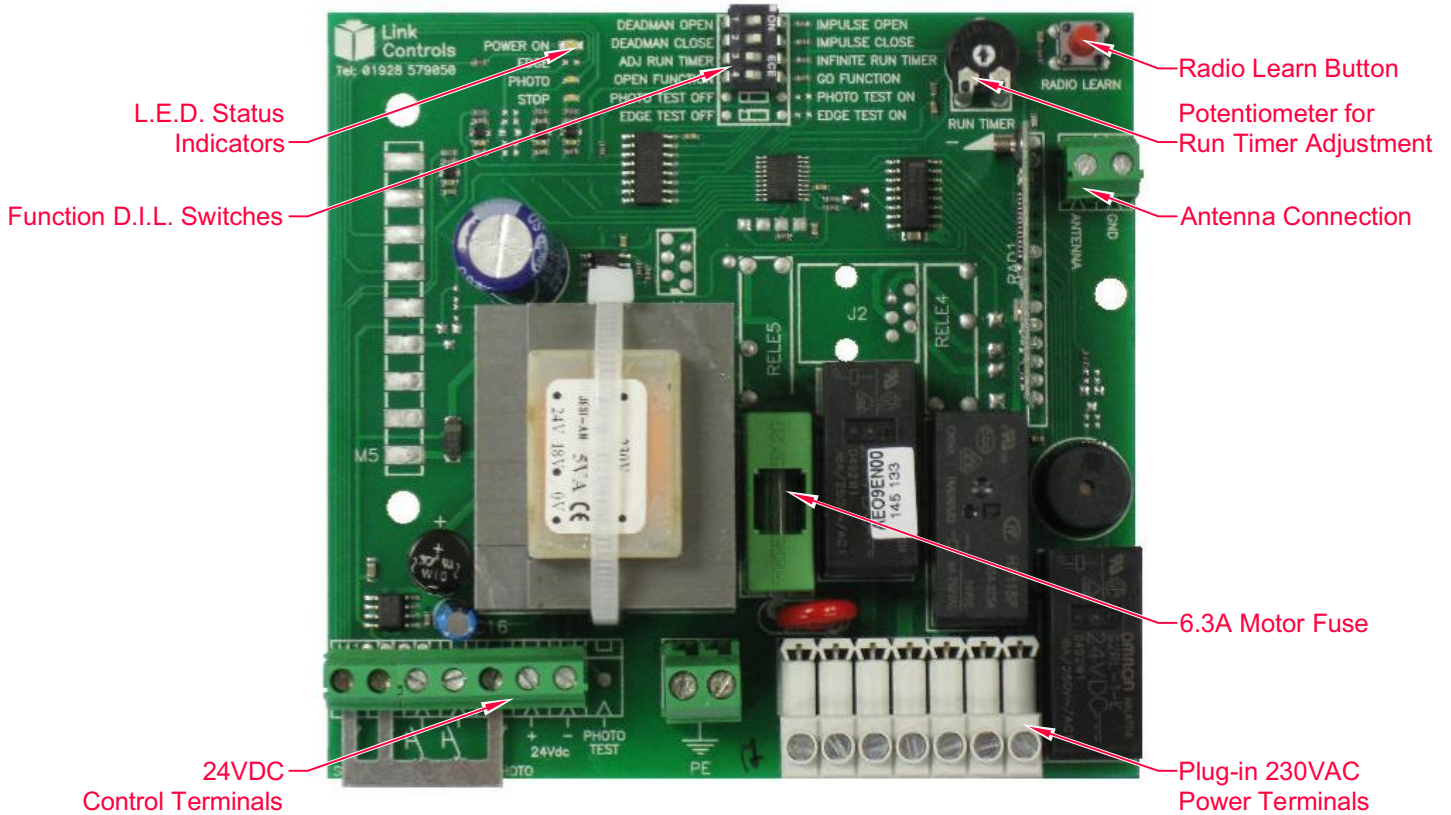

Basic Connections

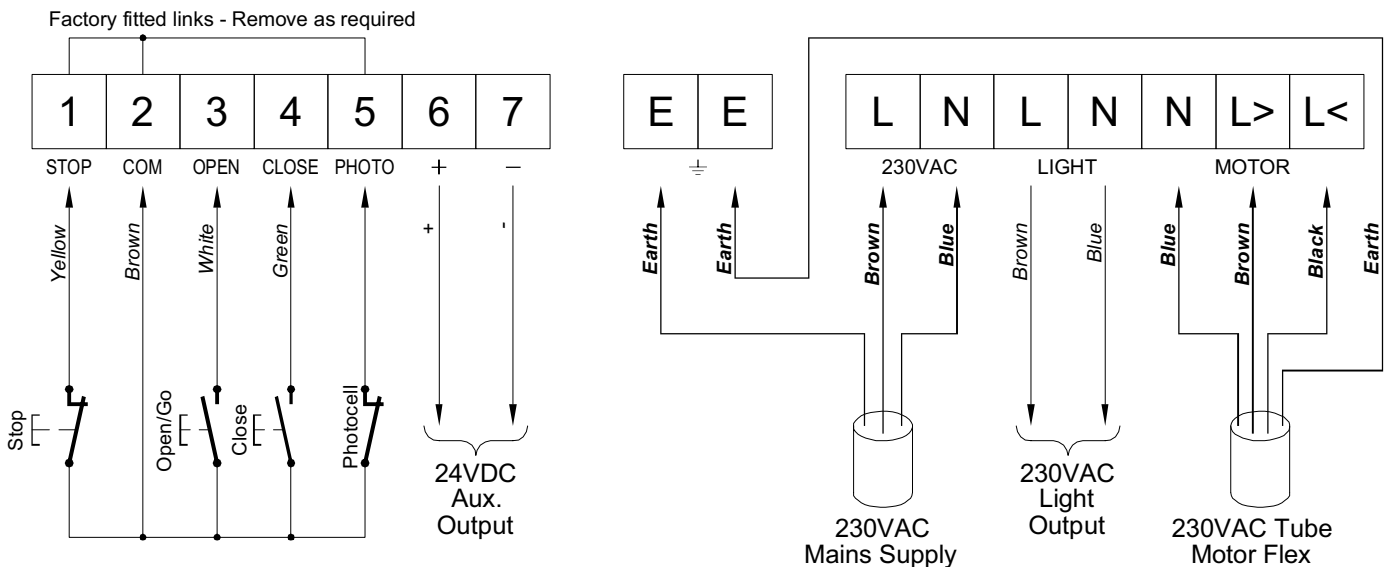

Installation Instructions

1. Fix the control panel to the wall using the 4 mounting holes provided, taking care not to damage the circuit board.
2. The wiring should be fed through the grommets provided at the bottom of the panel.
The 230VAC mains supply should be fed from a suitable fused supply and connected to terminals 'L', 'N' & 'PE', as shown.
Alternatively, use the plug (*if supplied*).
3. The motor can now be wired by connecting the motor flex's blue, brown, black & green/yellow wires, as shown.
Note:- The maximum load for the motor is 1000W.
4. If a courtesy light is required then this can be wired into the 'LIGHT' terminals. The light will remain active for a 3min. period.
Note:- The maximum load for the light output is 500W.
5. Any accessories can now be connected (e.g. keyswitch, safety brake switch, safety edge, photocell, etc.).
If the motor runs in the wrong direction (for example if the motor closes when the photocell is broken), then interchange the brown & black motor wires.

Programming the Handsets

AE0911 (3 Button: Open - Stop - Close)

1. Press and release the 'Radio Learn' button (top right of the circuit board).
2. The receiver will 'Beep' slowly to indicate Programming mode.
3. Press and release all three handset buttons in sequence, the receiver will 'Beep' with each button press.
i.e. Press Open - 'Beep', then Stop - 'Beep' and finally Close - 'Beep', all within 3 seconds of each other.
Note:- The first button pressed will always be the 'Open' direction.
4. The receiver will give 2 long 'Beeps' and the handset is now learnt.
5. The receiver will then give 2 short 'Beeps' as the receiver exits the Programming mode.
6. Repeat the process above for any additional handsets.

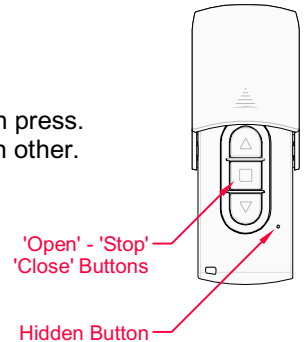

AE0901 (2 Button: Go - Stop)

1. Press and release the 'Radio Learn' button (top right of the circuit board).
2. The receiver will 'Beep' slowly to indicate Programming mode.
3. Press and release the top left button of the handset and the receiver will 'Beep' to confirm.
Note:- The first button pressed will always be the 'Open' direction.
4. The receiver will give 2 long 'Beeps' and the handset is now learnt.
5. The receiver will then give 2 short 'Beeps' as the receiver exits the Programming mode.
6. Repeat the process above for any additional handsets.

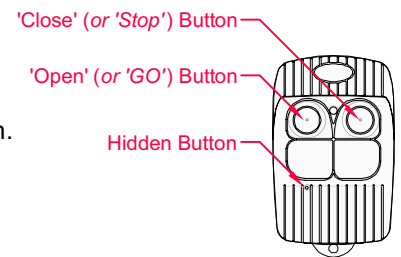

Programming New Handsets Using a Working Handset

Caution! If the hidden button is pressed for more than 1 second (i.e. several seconds) this can erase ALL of the handsets.

1. Stand as close as possible to the receiver (in working range of the handset), so the receiver 'Beep' is audible.
2. Using a paperclip press and release the hidden button on a working handset through the small hole.
(Bottom right of the AE0911 and bottom left of the AE0901).
3. The receiver will 'Beep' slowly to indicate Programming mode.
4. Program the new handset by repeating Steps 3-6 of the relevant handset programming instructions.

Erasing all of the Handsets

1. Remove the power from the Receiver.
2. Press and hold the 'Radio Learn' button.
3. Reapply the power whilst holding the 'Radio Learn' button.
4. The receiver will 'Beep' for 3 seconds.
5. When the 'Beep' stops, release the 'Radio Learn' button.
6. Memory is now erased.

D.I.L. Switch Functions

DIL1 : DEADMAN OPEN : IMPULSE OPEN	- Open only whilst the handset is pressed - Open automatically on one press of the handset
DIL2 : DEADMAN CLOSE * : IMPULSE CLOSE	- Close only whilst the handset is pressed - Close automatically on one press of the handset
DIL3 : ADJUSTABLE RUN TIMER : INFINITE RUN TIMER	- Run in the open or close direction for the time set using the pot. (1-90s) - Run in the open or close direction until a stop command is received
DIL4 : OPEN FUNCTION (suitable for 3-button handsets)	- One button for OPEN (and Stop closing) - One button for CLOSE (and Stop opening)
: GO FUNCTION (suitable for 2-button handsets)	- One button for GO (Open-Stop-Close-Stop sequence) - One button for STOP

***IMPORTANT!**

The Deadman Close function must be selected when the safeguarding of the main closing edge cannot be guaranteed, for example on a shop doorway (EN 12453).

Note:- The 'GO FUNCTION' is only possible if DIL switches 1 & 2 are both set to IMPULSE.
The 'OPEN' pushbutton input will also act as a 'GO FUNCTION' if this function is enabled.
The 'CLOSE' pushbutton input will always act as a close.

Adjustable Run Timer Potentiometer

If selected (DIL3 OFF), the motor will run for the time set by the potentiometer (1-90s). This should be set for a few seconds longer than the door takes to open or close. This will allow the photocell / safety edge to be disabled when the door is fully closed - preventing the door from accidental re-opening.

Other Auxiliary Connections

Remove link if Interlock/
Safety Brake is fitted

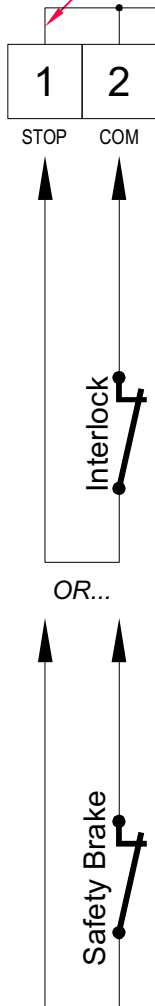

Retain link if NO Interlock/
Safety Brake is fitted

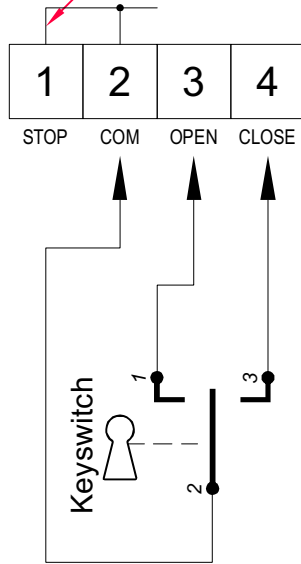

Remove link if Photocell/
Evaluation Relay is fitted

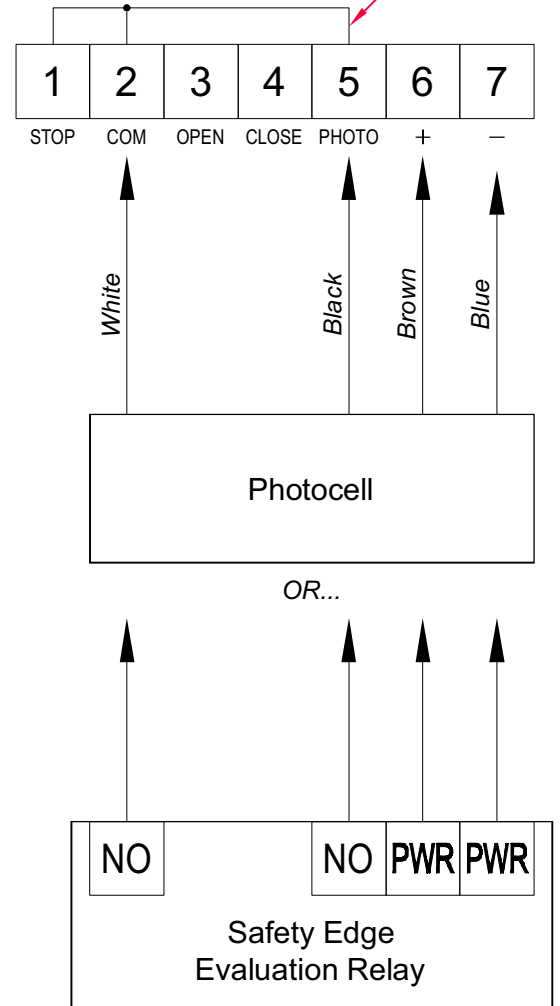

Technical Details

Supply Voltage	230 VAC +10% -15% 50-60Hz
Receiver Load (on mains)	4.4W Max.
Maximum Motor Load	1000W (230VAC)
Maximum Light Load	500W (230VAC)
Receiver Frequency	433.92MHz
Receiver Type	SAW Filter, Narrow Band.
Receiver Coding	Rolling Code Birol - 64 Bit
Maximum Number of Stored Transmitters	1000
Working Temperature	-10...+55°C
Fuse	6.3A Anti-Surge

DISCLAIMER: Marantec UK Ltd. constantly strives to improve the quality of its goods and as such reserves the right to replace/modify products without prior notification. Any examples given are intended for guidance only.