

Operating Instructions for:

CS 300RM



Warning : Please read these instructions fully before installation

1. Contents

1.	Contents	2
2.	Key to symbols	2
3.	General safety instructions	2
4.	Overview of products	3
5.	Initial operation	5
6.	Programming with the LED module	10
7.	Programming with the LCD monitor	12
8.	Navigator (LCD monitor only)	14
9.	Overview of functions	16
10.	Error messages and rectification	23
11.	Technical data	24
12.	EC Declaration of Incorporation	25
13.	Appendix	26

2. Key to symbols



Danger of personal injury!

The safety instructions must be observed!



Warning! Danger to property!

The safety instructions must be observed!



Information

Special information

OR

Reference to other sources of information

3. General safety instructions

Original operating instructions

- Protected by copyright.
- No part of this manual may be reproduced without our prior approval.
- Subject to alterations in the interest of technical progress.
- All dimensions are given in millimetres.
- The diagrams in this manual are not to scale.

Guarantee

The function and safety of the equipment is only guaranteed if the warning and safety instructions included in these operating instructions are adhered to.

MFZ Antriebe GmbH + Co. KG is not liable for personal injury or damage to property if these occur as a result of the warnings and safety advice being disregarded.

Using the equipment for its intended purpose

The CS 300 RM control unit is intended exclusively for the purpose of controlling tubular drives that have mechanical limit switch systems.

Target group

Only qualified and properly trained electricians are allowed to connect up, programme or service the control unit.

Qualified and trained electricians must have the following:

- Knowledge of the general and specific safety and accident-prevention regulations
- Knowledge of the relevant electrical regulations
- Training in the use and care of appropriate safety equipment
- The ability to recognise the risks associated with electricity

Instructions relating to installation and connection

- Before commencing electrical works, the system must be disconnected from the power supply. Measures must be taken to ensure that the power supply remains switched off for the duration of the works.
- The local safety regulations must be observed.
- Power cables must be laid separately from control cables.

4. Overview of products

Regulations and test specifications

The following regulations must be complied with when connecting, programming or servicing the unit. (The list is not exhaustive.)

Construction product standards

- EN 13241-1 (Products without fire resistance or smoke control characteristics)
- EN 12445 (Safety in use of power operated doors - Test methods)
- EN 12453 (Safety in use of power operated doors - Requirements)
- EN 12978 (Safety devices for power operated doors and doors - Requirements and test methods)

EMC

- EN 55014-1 (Electromagnetic compatibility - Requirements for household appliances)
- EN 61000-3-2 (Limits for harmonic current emissions)
- EN 61000-3-3 (Limitation of voltage changes, voltage fluctuations and flicker in public low-voltage supply systems)
- EN 61000-6-2 (Electromagnetic compatibility (EMC) - Part 6-2: Generic standards - Immunity for industrial environments)
- EN 61000-6-3 (Electromagnetic compatibility (EMC) - Part 6-3: Generic standards - Emission standard for residential, commercial and light-industrial environments)

Machinery Directive

- EN 60204-1 (Safety of machinery, electrical equipment of machines, Part 1: General requirements)
- EN 12100-1 (Safety of machinery - Basic concepts, general principles for design, Part 1: Basic terminology, methodology)

Low voltage

- EN 60335-1 (Household and similar electrical appliances - Safety)
- EN 60335-2-103 (Particular requirements for drives for gates, doors and windows)

Committee for Workplaces (Ausschuss für Arbeitsstätten - ASTA)

- ASR A1.7 (Technical Regulations for workplaces - Doors and gates)

4.1 Various options

The following package options are available for the CS 300 RM controls:

- CS 300 RM control unit with LCD monitor
- CS 300 RM control unit with LCD monitor in housing
- CS 300 RM control unit with LED module for setting the OPEN and CLOSED door positions (no further settings are possible).
- CS 300 RM control unit without LED module and without LCD monitor (a module or monitor is required for adjusting the settings)

All the above options can be fitted with a plug-in weekly timer (switch clock) and a plug-in radio receiver.

The following options are available for the housing:

- Housing unit with 3-button input unit CS
- Housing unit with 3-button input unit KDT
- Housing with ON/OFF key switch
- Housing with mains switch
- Housing with emergency off button

The operating instructions describe the connection options and programming procedures for the following models:

- CS 300 RM control unit with LED board
- CS 300 RM control unit with attached LCD display board

4. Overview of products

4.2 CS 300 RM main board (with attached LCD display monitor)

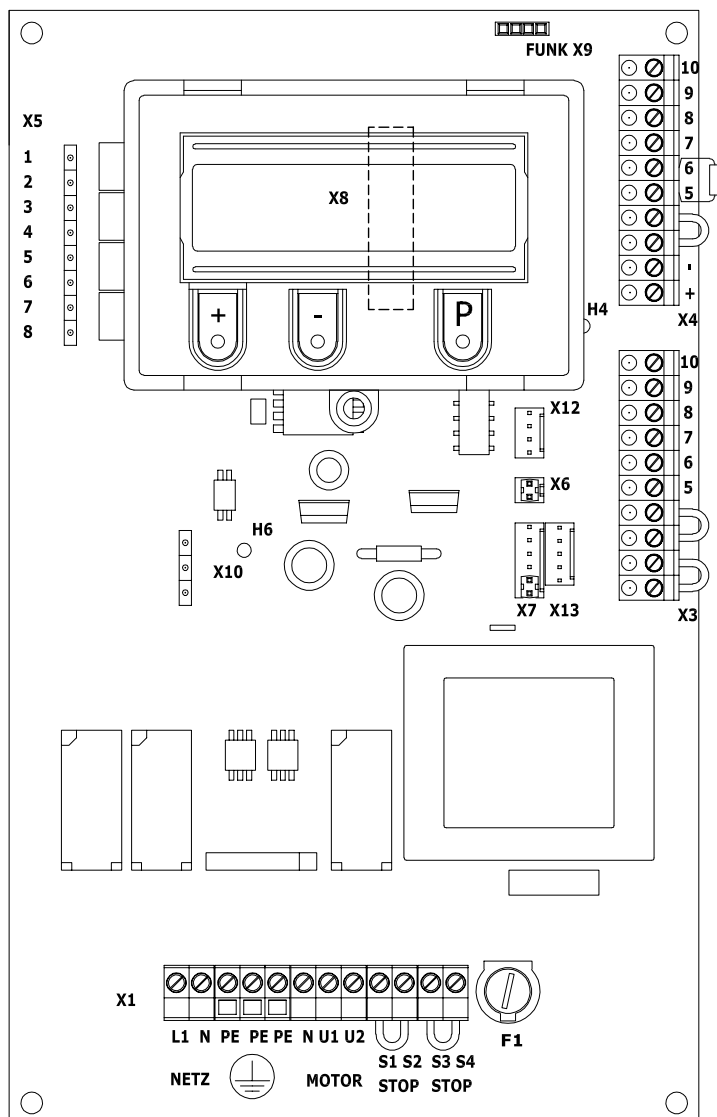

Key:

- X1: terminal block for mains connection / motor
- X3: terminal block for command devices
- X4: terminal block safety devices / before-end switch
- X5: terminal block relay
- X6: terminals for internal ON-OFF switch
- X7: terminals for internal 3-button input unit
- X8: socket for monitor (under monitor)
- X9: terminals for radio receiver
- X10: terminals for weekly timer (switch clock)
- X12: socket for external radio receiver
- X13: terminals for CS 3-button input unit
- H4: status display for safety edge protection (SKS) – illuminated when SKS is working
- H6: Safety circuit status message – lights up when the safety circuit is closed
- F1: 4A fuse

5. Initial operation

GB

5.1 General



Warning!

To guarantee that the equipment functions properly, the following points must be ensured:

- The door is installed and operational.
- The MFZ tubular drive is installed and ready for operation.
- The command and safety devices are installed and ready for operation.
- The control housing with the CS 300 RM control unit is installed.



Information:

For the installation of the gate/door, the MFZ geared motor and the command and safety devices, the relevant manufacturer's instructions are to be adhered to.

5.2 Mains connection



Danger!

To ensure that the control unit functions properly, the following conditions must apply:

- The supply voltage must correspond to the voltage shown on the type plate.
- The supply voltage must correspond to the voltage of the door operator.
- If a permanent connection is to be made, an all-pole mains switch must be installed.



Warning!

Before switching on the control unit for the first time, check to ensure that the cabling works are complete and that all the motor connections are secure at both the motor and the control unit. All control voltage inputs are separated galvanically from the mains power supply.

5. Initial operation

5.3 Assignment of connections for the motor and the power supply (terminal X1)

Terminal block X1

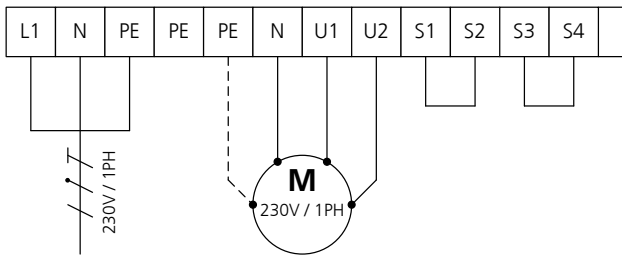

S1-S4
Connection of mains switch (optional)

Connection:

- Connect the control unit to the mains.
- Connect the control unit to the motor.
- Cable groups must be secured in place with a cable tie close to their terminals.



Information:

Technical data, see page 24.

5.4 Assignment of connections for command and safety devices

Command and safety devices can be connected to terminals X3, X4 and X5.

Terminal block X3

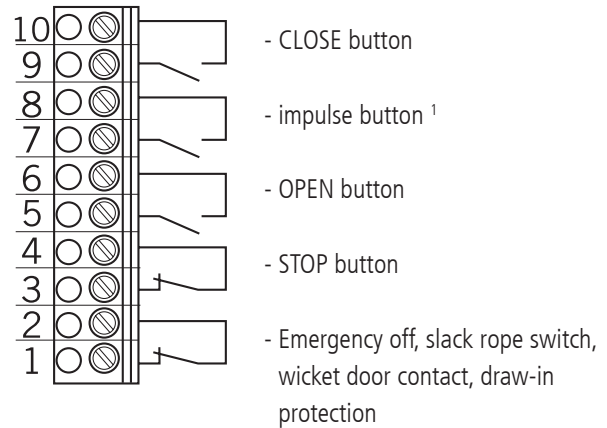

Terminal block X4

(for optoelectronic safety edge protection)

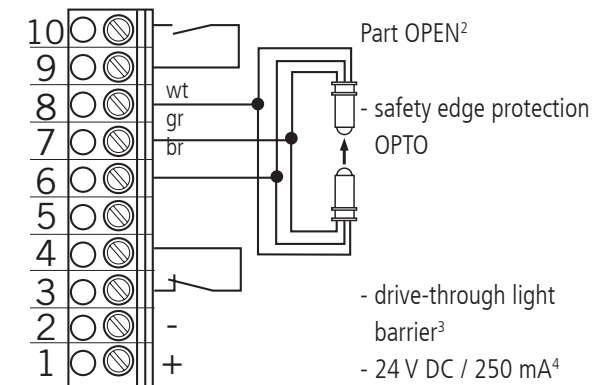

¹ sequence control

² button or selector switch

³ effective in down direction

⁴ for external switching devices (connection to terminals 1 and 2)

wt: white
gr: green
br: brown

Terminal block X4

(for 8.2 kOhm safety edge protection)

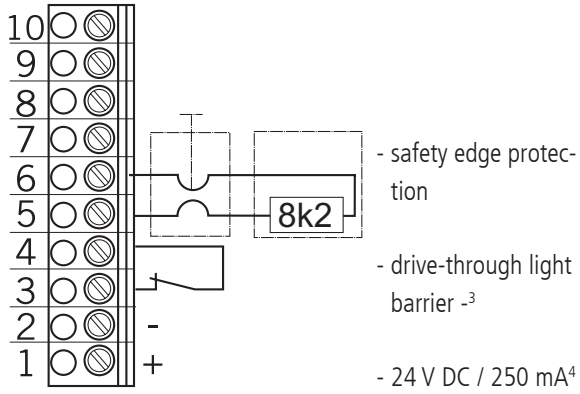

Klemmleiste X4

(mit Vorendschalter für Reversierabschaltung)

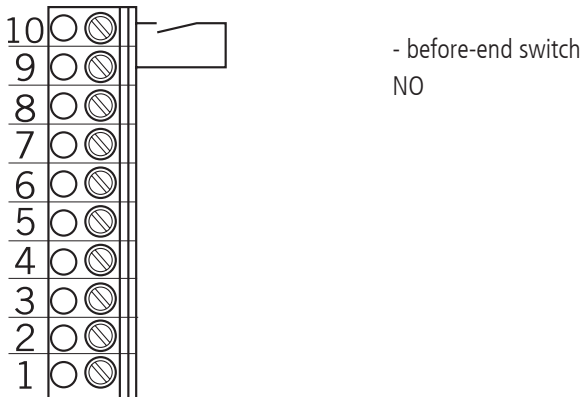

Terminal block X4

(for 3-wire light barrier)

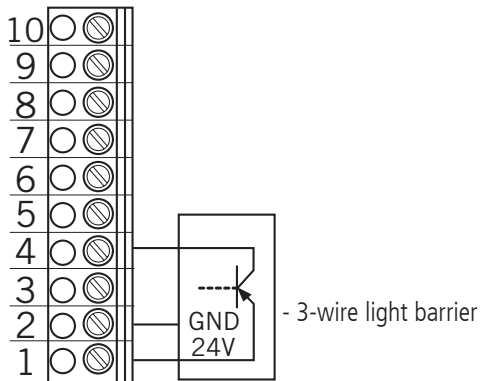

Terminal block X5

(potential-free switch contacts)

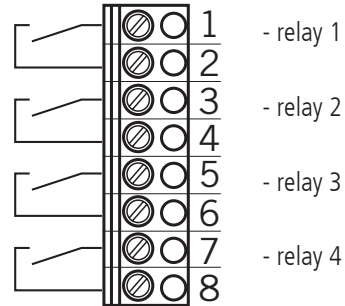

5. Initial operation

5.5 Connection examples for command and safety devices (terminal X3)

OPEN / STOP / CLOSE buttons

(6-lead solution)

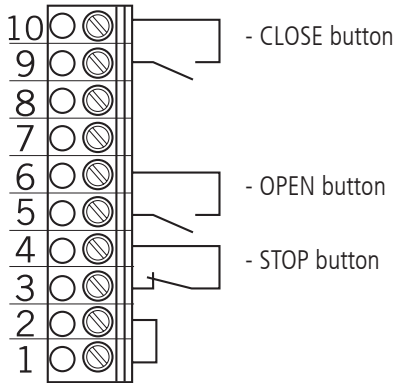

OPEN / STOP / CLOSE buttons

(4-lead solution)

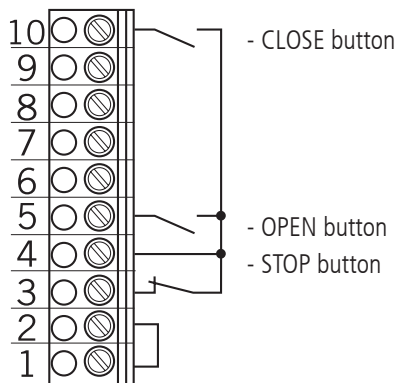

Key switch OPEN / CLOSE

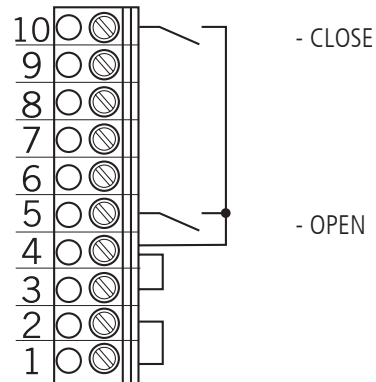

Impulse button

(sequence control)

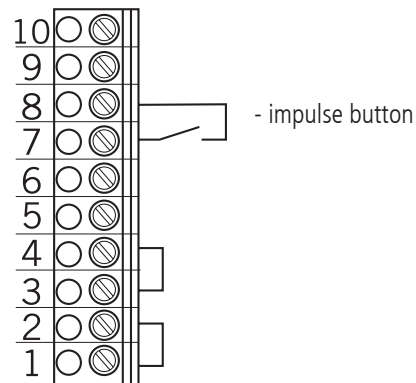

Connection:



- Connect any installed command and safety devices to the control unit.

6. Programming with the LED module

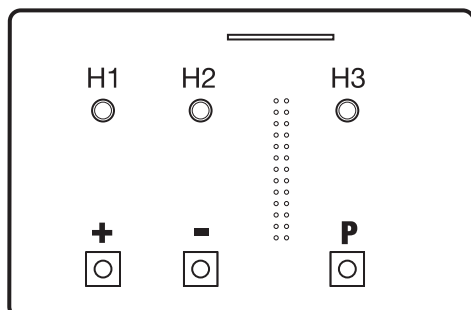
6.1 Overview of the LED module



Key:

-  LED off
-  LED illuminated
-  LED flashing

6.2 Operating modes of the LED module

With the LED module, the control unit has two modes of operation:

1. AUTOMATIC
2. ADJUSTMENT



Information:

The current mode of operation of the control unit is shown via the LEDs.

- In AUTOMATIC mode, no LEDs flash. The (+) and (-) buttons have no function.









- In the ADJUSTMENT mode, at least one LED flashes. The external buttons have no function.

Pressing the (P) button toggles between the modes of operation.

Operating mode 1: AUTOMATIC

In the AUTOMATIC operating mode the door system is operated automatically.







LED displays:

H1	H2	Status
		The door is open. The OPEN limit switch has been reached.
		The door is closed. The CLOSED limit switch has been reached.
		The door is between end positions. No limit switch has been reached.
		The OPEN and CLOSE limit switches have been interrupted (illogical state = TERM SWITCH FAIL).

Operating mode 2: ADJUSTMENT





In deadman mode, the OPEN/CLOSED end positions can be set.

LED displays:





H1	H2	Status
		The OPEN end position is programmed at this door position.
		The CLOSED end position is programmed at this door position.
		The CLOSED and OPEN end positions are not programmed at this door position.

6.3 Setting the end positions

Setting the OPEN end position

-  Change the mode of operation to ADJUSTMENT by pressing the (P) button.
-  Press the (+) button to drive the door to the desired end position in the OPEN direction.
-  Adjust the mechanical limit switches.
-  Change to AUTOMATIC mode by pressing the (P) button.

Setting the CLOSED end position

-  Change the mode of operation to ADJUSTMENT by pressing the (P) button.
-  Press the (-) button to drive the door to the desired end position in the CLOSE direction.
-  Adjust the mechanical limit switches.
-  Change to AUTOMATIC mode by pressing the (P) button.



Warning!

The door can be damaged if driven beyond the end position.

7. Programming with the LCD Monitor

7.1 Overview of the LCD monitor

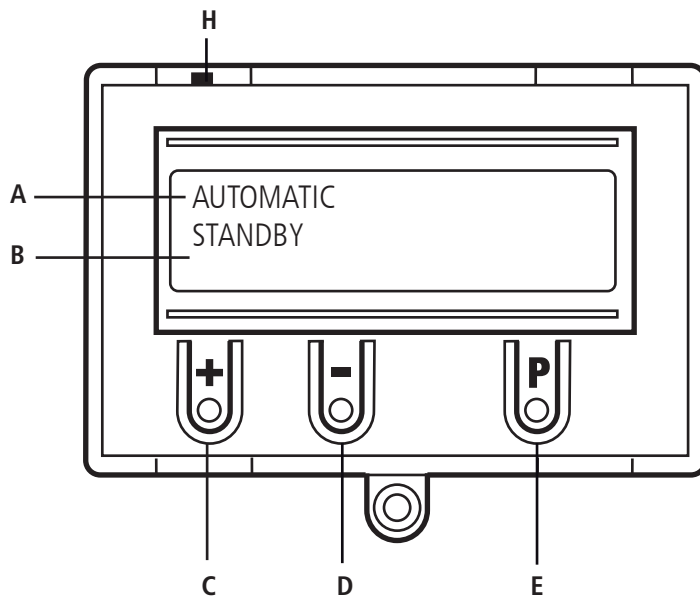

Key:

- A: Operating mode /
Diagnosis info
- B: Parameters /
Diagnosis info
- C: (+) button
- D: (-) button
- E: (P) button
- H: Jumper

7.2 Operating modes of the LCD monitor

The control unit has four modes of operation with the LCD monitor:

1. AUTOMATIC
2. ADJUSTMENT
3. INPUT
4. DIAGNOSIS

When the jumper H is removed, the (+) button, the (-) button and the (P) button have no function. The display still continues to function.

Operating mode 1: AUTOMATIC

In the AUTOMATIC operating mode the door system is operated automatically.

Display:

- Displays the action being carried out.
- Displays any errors.

If the "self locking" parameter in the Input menu is set to MOD2 or MOD3, then the display changes from AUTOMATIC to MANUAL.

The (+) and (-) buttons have no function.

Operating mode 2: ADJUSTMENT

In ADJUSTMENT mode, the door is driven to the OPEN/CLOSED end positions in deadman mode and the mechanical limit switches are set.

Display:

- Displays the operating status

The external buttons have no function.

Operating mode 3: INPUT

In the INPUT operating mode, the values of various parameters can be altered.

Display:

- Displays the selected parameter
- Displays the set value or status

Operating mode 4: DIAGNOSIS

In DIAGNOSIS mode, door-related monitoring can be carried out.

Display:

- Displays the monitored function
- Displays the status of the function

8. Navigator (LCD monitor only)

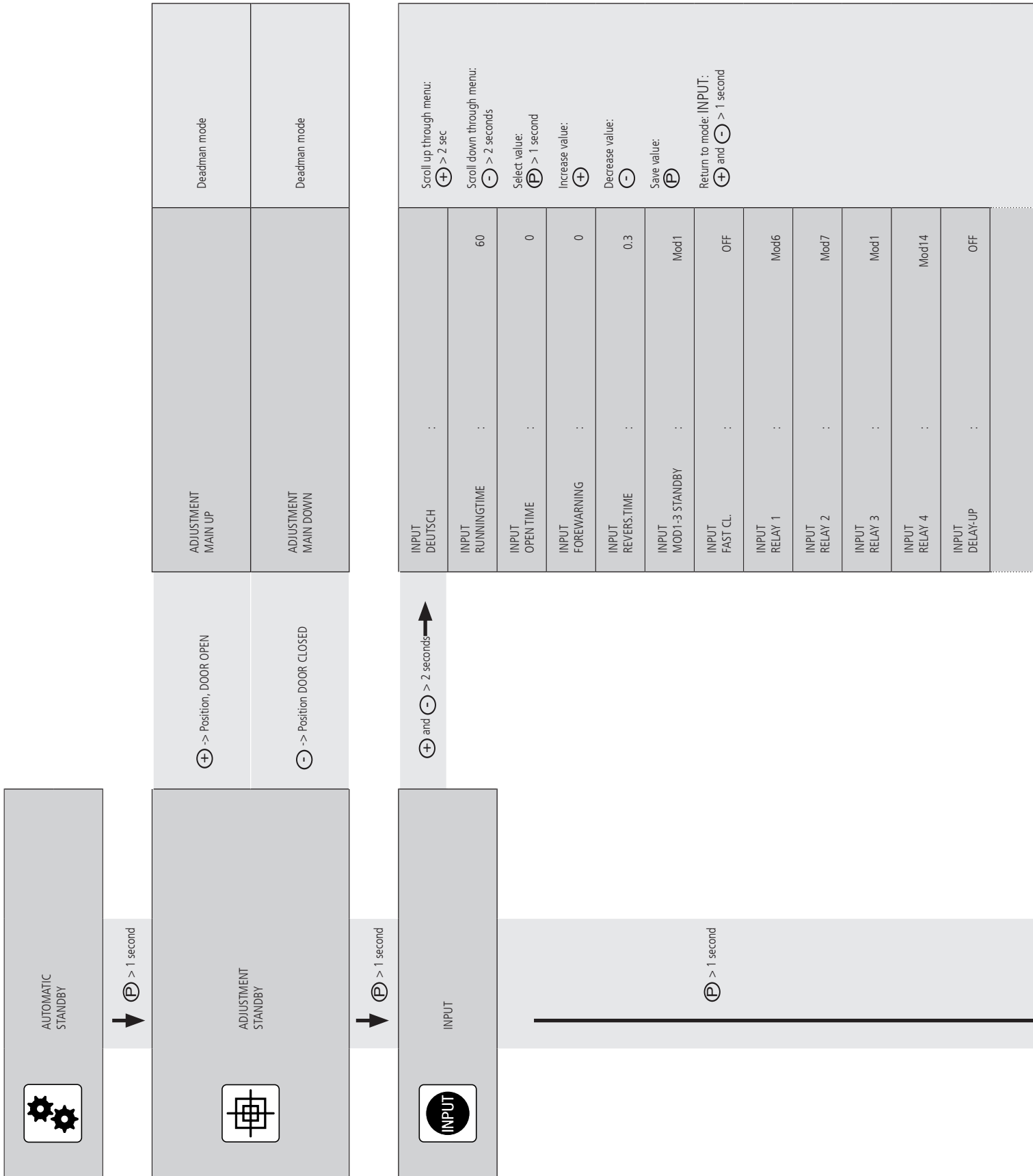

INPUT SELF LOCK	:	MOD1
INPUT SU/WI	:	MOD1
INPUT REVERS	:	MOD1
INPUT LB OPEN	:	MOD2
INPUT LB CLOSE	:	MOD1
INPUT SKS LEAD	:	MOD1



DIAGNOSIS

UP-SWITCH SECT.-SWITCH	:	OFF	OFF
DOWN-SWITCH SKS	:	OFF	ON
IMPULS SWITCH CLOCK	:	OFF	OFF
LIGHT BARR STOP CHAIN	:	ON	ON
BES-OPEN BES-CLOSE	:	ON	ON
CYCLE	:		4

Scroll up through menu:
 (+) > 2 seconds

Scroll down through menu:
 (-) > 2 seconds

Return to mode -AUTOMATIC:
 (P)

Only query is possible

9. Overview of functions

9.1 Automatic operating mode

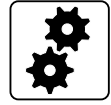

Display	Description
AUTOMATIC OPENING PHASE	The door is driven to the OPEN end position
AUTOMATIC CLOSING PHASE	The door is driven to the CLOSED end position
AUTOMATIC STANDBY	The door is stationary



Information:

If the "self locking" parameter in the Input menu is set to MOD2 or MOD3, then the display changes from AUTOMATIC to MANUAL.

Display	Description
MANUAL MAIN UP	The door is driven to the OPEN end position
MANUAL MAN CLOSE	The door is driven to the CLOSED end position
MANUAL STANDBY	The door is stationary



9.2 Input operating mode

Function	Description	Possible settings	Factory setting
ENGLISH	Select the menu language	DEUTSCH ENGLISH FRANCAIS ESPANOL NEDERLANDS POLSKI CESKY ITALIANO	ENGLISH
RUNNING-TIME	Monitors the maximum running time for an open and close movement	1 – 250 seconds	60 seconds
OPEN TIME	After the door has opened, it runs in the CLOSE direction again after the set time has elapsed. Open time > 0 = impulse functions only in the OPEN direction	0 – 600 seconds	0 = Auto close off
FOREWAR-NING	The traffic light flashes before the door starts to close. The preset forewarning time is only active if the open time is > 0 or if operated via radio impulse.	0 – 120 seconds	0 = Off
REVERS-TIME	Time spent stationary each time the door changes direction	0.1 - 2.0 seconds (in 1/10 second steps)	0.3 seconds
MOD1-3 STANDBY	MOD 1: OFF when resting MOD 2: ON when resting	MOD1 MOD2	MOD1
FAST CL.	ON: The open time is interrupted after a vehicle passes the light barrier (the door then closes immediately). This function is also active if the open time is set to 0. OFF: The open time continues as usual	ON OFF	OFF
RELAY 1	All 4 relays can have a relay module of 1 to 28 assigned to them.	MOD1 – MOD28	MOD6
RELAY 2	MOD1: Red traffic light lights up during door movement and flashes as a warning before door movement starts	MOD1 – MOD28	MOD7
RELAY 3	MOD2: Red traffic light flashes during door movement and as a warning before door movement starts	MOD1 – MOD28	MOD1
RELAY 4	MOD3: Red traffic light lights up during door movement and as a warning before door movement starts	MOD1 – MOD28	MOD14
	These 3 modes are affected by the parameter M1-3 STANDBY		
	MOD4: Impulse when OPEN command is given MOD5: Error message MOD6: OPEN end position MOD7: CLOSE end position MOD8: OPEN end position negated MOD9: CLOSE end position negated MOD11: Pre-limit position CLOSE MOD12: Pre-limit CLOSE position to CLOSE end position MOD13: Magnetic lock function MOD14: Brake MOD15: Brake negated MOD16: Brake remains ON during open time MOD17: Safety edge protection (SKS) activated MOD18: (Red traffic light 4) Forewarning - flashing Door movement - off MOD20: Activation of the optoelectronic transmission system MOD21: Test of draw-in protection before door opening run (additional module required) MOD22: Test of external safety devices before door closing run (additional module required)		

9. Overview of functions

Function	Description	Possible settings	Factory setting
	<p>MOD23: (Green traffic light) OPEN end position - light on Forewarning - OFF Door movement - OFF</p> <p>MOD25: Yard light function 2 minutes after OPEN command</p> <p>MOD26: Activation of radio transmission system</p> <p>MOD27: Impulse signal after end position in the OPEN direction has been reached.</p> <p>MOD28: Relay OFF</p>		
DELAY-UP	<p>ON: Gives forewarning before opening</p> <p>OFF: Opens immediately</p>	<p>ON</p> <p>OFF</p>	OFF
SELF LOCK	<p>MOD1: Automatic operation</p> <p>MOD2: Manual operation for OPEN + CLOSE</p> <p>MOD3: Manual operation for CLOSE</p>	MOD1 - MOD3	MOD1
SU/WI	<p>Connection to terminal block X4 (9 + 10)</p> <p>MOD1: Pre-limit switch CLOSE (N.O.)</p> <p>MOD6: Activation of automatic closing Closed: No automatic closing of the door Open: Automatic closing of the door is active</p> <p>MOD7: External input for timer (switch clock) The door opens as soon as the contact closes and then remains at the OPEN position until the contact opens. The door then closes automatically. This function can be aborted by pressing the CLOSE button. The door then closes.</p> <p>MOD9: Continuous CLOSE signal 1 Closed: Door CLOSSES with safety devices activated and remains in CLOSED position until contact opens. OPEN commands are ignored. If the safety edge protection (SKS) is triggered 3 times, the door then remains in the OPEN position. Open: Normal function</p> <p>MOD10: Continuous CLOSE signal 2 As for MOD9 except that after the SKS has been triggered 3 times, the door reverses for 750 ms and then remains stationary in that position.</p>	MOD1 - MOD10	MOD1
REVERS	<p>MOD1: No reversing takes place if the pre-limit switch CLOSE is activated.</p> <p>MOD2: No reversing takes place even when the pre-limit switch CLOSE is activated.</p>	<p>MOD1</p> <p>MOD2</p>	MOD1
LB CLOSE	<p>MOD1: Stop when triggered</p> <p>MOD2: Stop and reverse when triggered</p>	<p>MOD 1</p> <p>MOD 2</p>	MOD 2
LB OPEN	<p>MOD1: Light barrier not active</p> <p>MOD2: If the light barrier is triggered between the pre-limit CLOSE position and the CLOSE end position, the door stops moving. The red traffic light lights up. The pre-limit switch CLOSE is set automatically to the CLOSED end position + 600.</p>	<p>MOD 1</p> <p>MOD 2</p>	MOD 1
SKS LEAD	<p>MOD1: No function</p> <p>MOD2: Leading light barrier (MFZ)</p>	<p>MOD 1</p> <p>MOD 2</p>	MOD 1

Explanation of the relay modes:

A. Traffic light functions

MOD	Description	CLOSED end position	OPEN end position	Forewarning	Door moving
MOD 1	Red traffic light 1	ON / OFF *	OFF	Flashing	Continuously lit
MOD 2	Red traffic light 2	ON / OFF *	OFF	Flashing	Flashing
MOD 3	Red traffic light 3	ON / OFF *	OFF	Continuously lit	Continuously lit
MOD 18	Red traffic light 4	OFF	OFF	Flashing	OFF
MOD 23	Green traffic light	OFF	Continuously lit	OFF	OFF

* Depends on parameter MOD1-3 REST

B. Position messages

MOD	Description	Comments
MOD 6	OPEN end position	The relay closes the contact when the door is in the OPEN end position.
MOD 7	CLOSED end position	The relay closes the contact when the door is in the CLOSED end position.
MOD 8	Not OPEN end position	The relay closes the contact when the door is not in the OPEN end position.
MOD 9	Not CLOSED end position	The relay closes the contact when the door is not in the CLOSED end position.
MOD 11	Pre-limit position CLOSE	The relay closes the contact when the door is in the pre-limit position CLOSE.
MOD 12	Pre-limit position CLOSE to CLOSED end position	The relay closes the contact when the door is in the area between the CLOSED end position and the pre-limit position CLOSE.*

* Only possible if an external pre-limit switch (MOD 1) is connected to the SU/WI input (X4 9+10).

9. Overview of functions

C. Impulse signals

MOD	Description	Comments
MOD 4	Impulse upon OPEN command	The relay closes the contact for 1 second when the door receives an OPEN command. This impulse can be used to control lights, for instance.
MOD 27	Impulse when OPEN end position is reached	The relay closes the contact for 2 seconds when the door reaches the OPEN end position. This impulse can be used, for instance, to open a second barrier.

D. Brake functions

MOD	Description	Comments
MOD 14	Brake	The switching contact of the brake rectifier is activated via the relay to achieve a faster brake function. The contact is closed, and the brake is therefore released, as soon as the door moves (zero current brake).
MOD 15	Brake negated	The switching contact of the brake rectifier is activated via the relay to achieve a faster brake function. The contact is opened, and the brake is therefore released, as soon as the door moves (operating current brake).
MOD 16	Brake remains ON during open time	The switching contact of the brake rectifier is activated via the relay to achieve a faster brake function. The contact is closed, and the brake is therefore released, as soon as the door moves (zero current brake). In order to stop the door more smoothly at the OPEN end position, the switching contact is not switched at the OPEN end position (OPEN TIME).

E. Error messages

MOD	Description	Comments
MOD 5	Error message	The relay closes the contact when a stop command is given or an error occurs. All errors described in section 10 result in activation of the relay.
MOD 17	Safety edge protection (SKS) activated	The relay opens the contact when the safety edge protection strip is activated. An error in the safety edge protection strip or an unsuccessful test is shown via MOD 5.

F. Functions for external accessories

MOD	Description	Comments
MOD 13	Magnetic lock function	The relay is open in the CLOSED end position. If an OPEN command is received, the relay closes and remains closed until the CLOSED end position is reached again. If a time delay is required for opening the magnetic lock, this is achieved via the DELAY-UP and Forewarning parameters.
MOD 20	Activation of the optoelectronic transmission system	Before every CLOSE command, the optoelectronic transmission system is activated and remains active for the duration of the closing run. This activation results in a closing run delay of approx. 0.5 seconds.
MOD 21	Test of draw-in protection	The relay generates a test signal when the CLOSED end position is reached and expects that the safety circuit is then activated in response to the test signal.
MOD 22	Test of external safety devices	The relay generates a test signal when the OPEN end position is reached and expects that the safety edge protection strip input circuit is then activated in response to the test signal.
MOD 25	Yard light function	At every OPEN command, the relay closes for 2 minutes and can therefore be used to control a light.
MOD 26	Activation of radio transmission system	Before every CLOSE command, the radio transmission system is activated by an impulse. The duration of the activation must be set in the transmission system. This activation results in a closing run delay of approx. 0.5 seconds.
MOD 28	Relay OFF	The relay is always open.

9. Overview of functions

9.3 Diagnosis operating mode



Display	Meaning	Status
UP-SWITCH	UP-SWITCH	ON: activated OFF: not activated
SECT.-SWITCH	PART OPEN button (X4 / 9 + 10)	ON: activated OFF: not activated
DOWN SWITCH	DOWN button	ON: activated OFF: not activated
SKS	Safety edge protection	ON: System is closed OFF: System is interrupted (fault)
IMPULS	Impulse button	ON: activated OFF: not activated
SWITCH CLOCK	Weekly timer (switch clock)	ON: activated OFF: not activated
LIGHT BARR	Drive-through light barrier	ON: closed OFF: interrupted (fault)
STOP CHAIN	- Stop button of controls - Stop systems of drive	ON: closed OFF: interrupted (fault)
BES CLOSE	Pre-limit (before end) switch CLOSE	OFF: actuated ON: not actuated
CYCLE	Door cycle counter	Display shows the number of door cycles

10. Error messages and rectification

GB

Fault / error message	Cause	Rectification
System does not react	- No voltage supply present	- Check the voltage supply of the drive and the controls
Door travels to the CLOSE end position when the OPEN button is pressed Door travels to the OPEN end position when the CLOSE button is pressed	- Motor connected incorrectly	- Swap around U1 and U2
STOP	- The safety circuit is interrupted. X3 1,2: Emergency off, slack rope switch, wicket door contact, draw-in protection X6 1,2: Internal On-Off switch X11 4,8: Safety circuit of drive X2 B1/B2: Jumper X3 3,4: External stop button X7 1,2: Internal stop button	- Check and then close the safety circuit
ERROR RUNTIME	- The programmed running time has been exceeded	- Check the path of the door - Re-programme the running time
ERROR SKS	- Safety edge protection (SKS) is faulty - Safety edge protection has been triggered	- Check the safety edge protection and the spiral cable - Remove obstacle from path of door
ERROR SKS TEST	- The PS (pressure sensor) switch is not triggered at the CLOSE end position	- Check the PS switch, spiral cable and edge profile - Check the setting for the CLOSE end position

After rectifying the cause of the fault, the controls must be disconnected briefly from the mains!

11. Technical data

Dimensions Housing:	215 x 275 x 190 mm
Installation:	Mount vertically on a wall; minimum installation height: 1,100 mm
Supply voltage:	230 V/AC 50/60Hz
Switching current:	max. 4A
Switching capacity:	max. 920 VA
Internal fuse:	4AT
Fuse protection:	Type K 10A fuse
Intrinsic consumption of control unit	max. 250 mA
Control voltage:	24 V DC; maximum of 250 mA; protected by a self-resetting fuse for external sensors. All control voltage inputs are separated galvanically from the mains power supply.
Control inputs:	24 V DC; all inputs must be connected such that they are potential-free. The minimum signal duration for input control commands is > 100 ms.
Control outputs:	24 V DC; max. 250 mA
Safety circuit / Emergency off:	All input connections MUST be potential-free if the safety circuit is interrupted, no further door operator movement is possible – not even in deadman mode
Input for safety edge strip:	For electrical safety edge protection strips with 8,2 k Ω terminating resistance and for dynamic optical systems.
Relay outputs:	If inductive loads are connected (e.g. further relays or brakes), these must be equipped with suitable interference suppression (recovery diode, varistors or RC circuits). Normally-open potential-free contact; minimum of 10 mA; maximum of 230 V AC / 4 A. <i>Once contacts have been used in power circuits they can no longer be used for low currents.</i>
Temperature range:	In operation: -10 °C ... +45 °C In storage: -25 °C ... +70 °C
Air humidity:	Up to 80%, non condensing
Vibration:	Low vibration mounting, e.g. on a masonry wall
Protection category:	IP 65
Weight:	Approx. 1.8 kg

12. EC Declaration of Incorporation

We hereby declare that the product described below:

CS 300 RM Door Controls

is in conformity with all essential requirements of the Machinery Directive (2006/42/EC).

This partly completed machinery complies with all the regulations of the EC Construction Products Directive (89/106/EEC), EC Electromagnetic Compatibility Directive (2004/108/EEC) and the EC Low Voltage Directive (2006/95/EC).

The following standards were applied:

EN 60204-1

Safety of machinery - Electrical equipment of machines, Part 1: General requirements

EN 12100-1

Safety of machinery - Basic concepts, general principles for design, Part 1: Basic terminology, methodology

EN 12453

Safety in use of power operated doors - Requirements

EN 12604

Doors and gates - Mechanical aspects - Requirements

EN 61000-6-2

Electromagnetic compatibility (EMC) - Part 6-2: Generic standards - Immunity for industrial environments

EN 61000-6-3

Electromagnetic compatibility (EMC) - Part 6-3: Generic standards - Emission standard for residential, commercial and light-industrial environments

EN 60335-1

Household and similar electrical appliances - Safety

EN 60335-2-103

Particular requirements for drives for gates, doors and windows

GB

Manufacturer and manager of documentation

MFZ Antriebe GmbH & Co. KG, Neue Mühle 4, 48739 Legden, Germany

The special technical documents were prepared in accordance with Annex VII, Part B of EC Machinery Directive 2006/42/EC. We undertake to supply these documents, in electronic form and within a reasonable period, in response to a duly reasoned request from the market surveillance authorities.

The partly completed machine may not be set in operation until it has been ascertained that the machine in which the partly completed machine is to be installed complies with all the requirements of Machinery Directive (2006/42/EC).

Place and date

Legden, 1 October, 2013

Manufacturer's signature



Dirk Wesseling

Job description of the signatory

Director

13. Appendix

Overview of connections

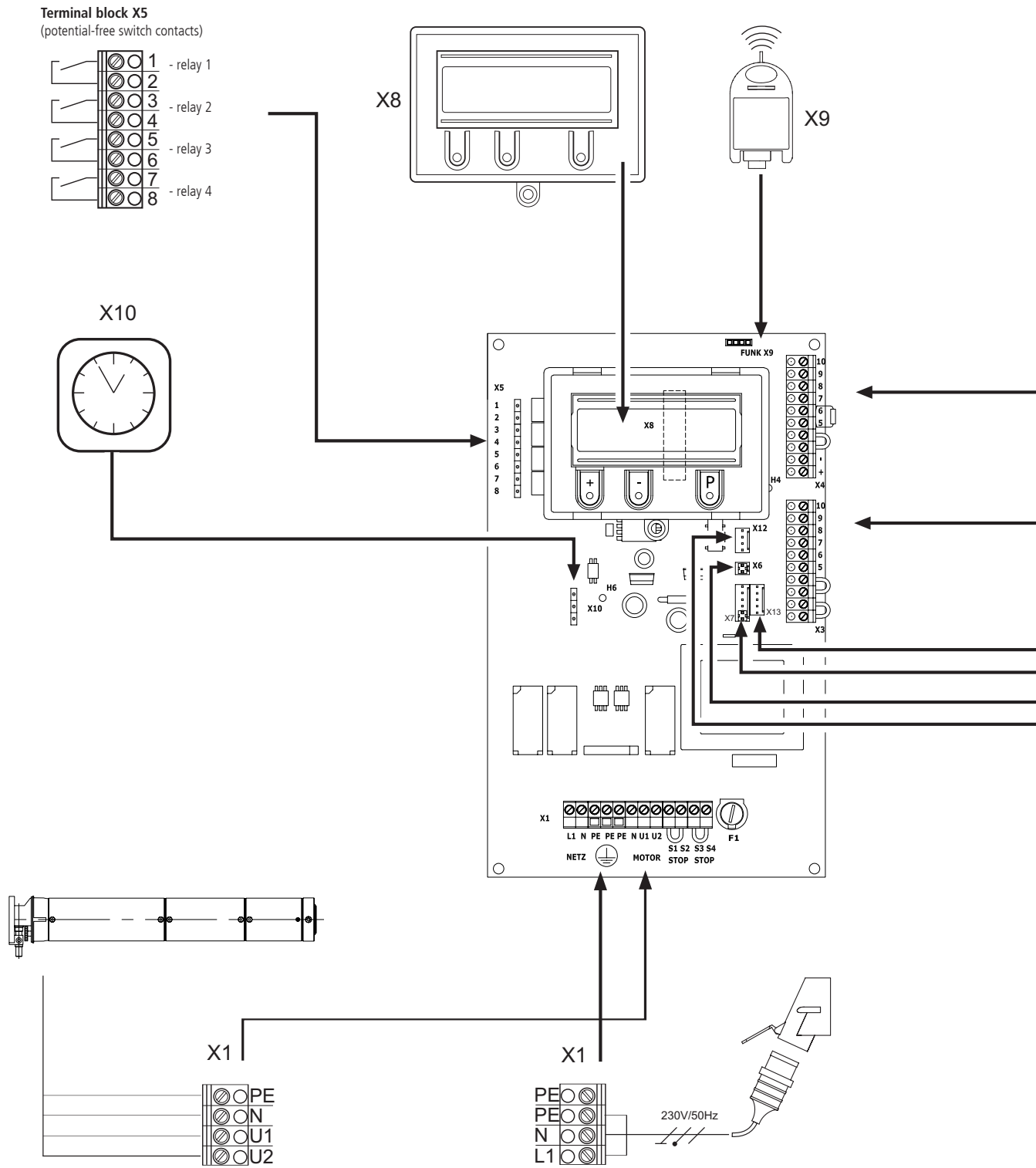

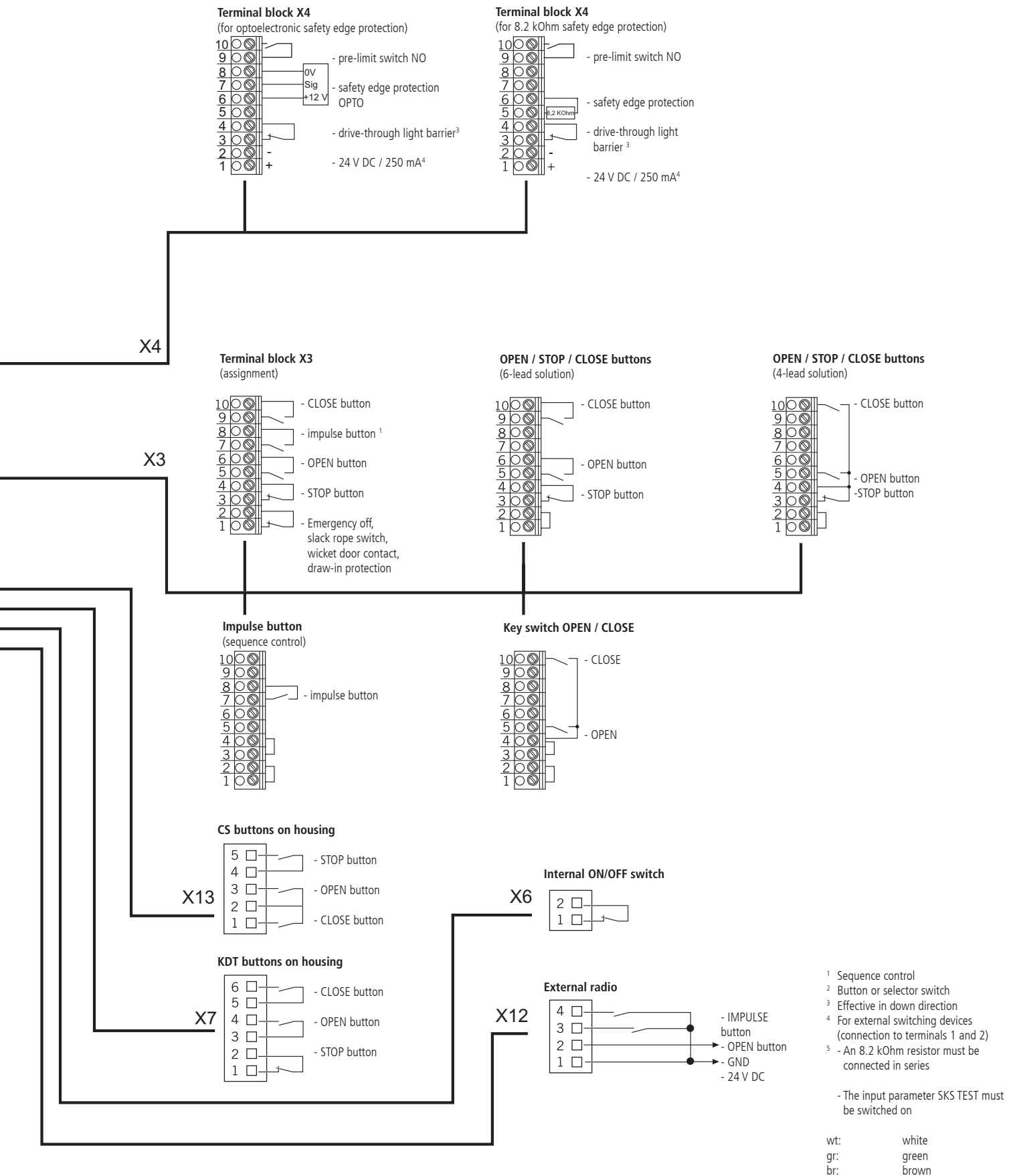

- ¹ Sequence control
- ² Button or selector switch
- ³ Effective in down direction
- ⁴ For external switching devices (connection to terminals 1 and 2)
- ⁵ - An 8.2 kOhm resistor must be connected in series

- The input parameter SKS TEST must be switched on

wt: white
gr: green
br: brown

