

Instructions for Sectional Door Operator type :

STA

Instructions for Rolling Door Operator type :

CDO100 Compact

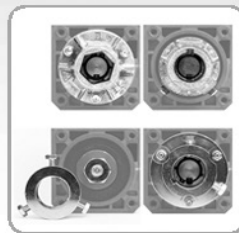
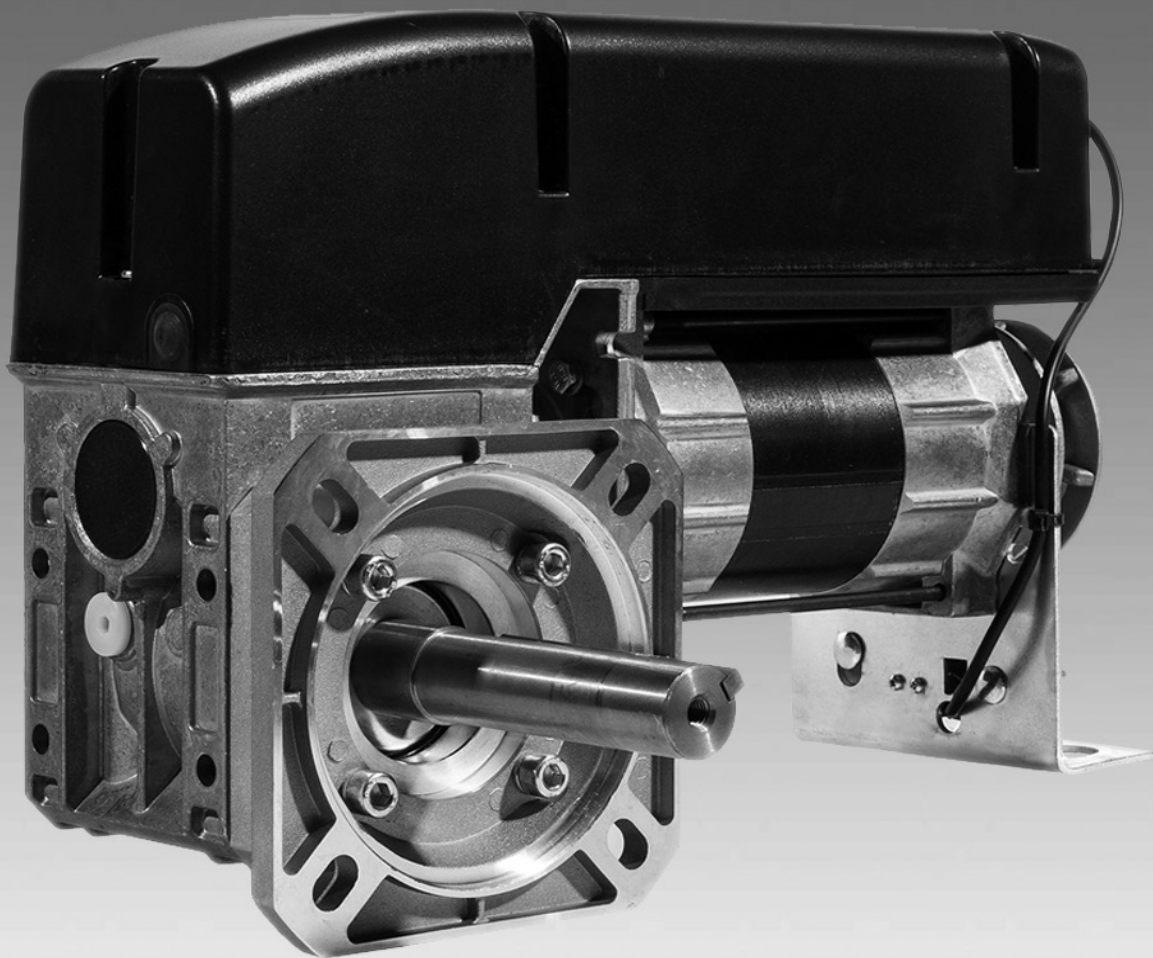

Warning : Please read these instructions fully before installation

1. Contents

1.	Contents	2
2.	Key to symbols	2
3.	General safety instructions	2
4.	Overview of products	3
5.	Installation	4
6.	Initial Operation	9
7.	Emergency operation	13
8.	Maintenance	15
9.	EU Declaration of Conformity	16

2. Key to symbols



Danger of personal injury!

The safety instructions must be observed!



Warning! Danger to property!

The safety instructions must be observed!



Information

Special information

OR

Reference to other sources of information

3. General safety instructions

Guarantee

The function and safety of the equipment is only guaranteed if the warning and safety instructions included in these operating instructions are adhered to.

Marantec UK is not liable for any personal injury or damage to property that occurs as a result of the warning and safety instructions being disregarded.

Marantec UK does not accept any liability or warranty for damage due to the use of non-approved spare parts and accessories.

Using the equipment for its intended purpose

Operators of the STA range are designed exclusively for opening and closing counter balanced sectional doors.

Operators of the CDO range are designed exclusively for opening and closing roller shutter doors (complete with installation of a safety brake as required)

Target group

Only qualified and trained specialists are permitted to install and service the operator. Qualified and trained professionals fulfil the following requirements:

- knowledge of the general and specific safety and accident prevention regulations,
- Knowledge of the relevant regulations,
- trained in the use and care of appropriate safety equipment,
- Capable of recognising the dangers associated with installation.

Only qualified and trained electricians may connect the operator and carry out electrical maintenance.

Qualified and trained electricians fulfil the following requirements:

- knowledge of the general and specific safety and accident prevention regulations,
- knowledge of the relevant electrical regulations,
- trained in the use and care of appropriate safety equipment,
- capable of recognising the dangers associated with electricity.

Instructions for installation and connection

- The controls must be disconnected from the electricity supply before carrying out electrical works. It must be ensured that the electricity supply remains disconnected during the works.
- Local protective regulations must be complied with.
- Mains cables and control cables must be laid separately.

Regulations and bases for testing

For connecting, programming and servicing, the following regulations must be observed (the list is not exhaustive).

Construction product standards

- EN 13241-1 (Products without fire resistance or smoke control characteristics)
- EN 12445 (Safety in use of power operated doors - Test methods)
- EN 12453 (Safety in use of power operated doors - Requirements)
- EN 12635 (Industrial, commercial and garage doors and gates - Installation and use.)
- EN 12978 (Safety devices for power operated doors and gates - Requirements and test methods)

Electromagnetic compatibility

- EN 55014-1 (Radio disturbance, household appliances)
- EN 61000-3-2 (Disturbances in supply systems - harmonic currents)
- EN 61000-3-3 (Disturbances in supply systems - voltage fluctuations)
- EN 61000-6-2 (Electromagnetic compatibility (EMC) - Part 6-2: Generic standards - Immunity for industrial environments)
- EN 61000-6-3 (Electromagnetic compatibility (EMC) - Part 6-3: Generic standards - Emission standard for residential, commercial and light-industrial environments)

Machinery guidelines

- EN 60204-1 (Safety of machinery, electrical equipment of machines, part 1: general requirements)
- EN 12100-1 (Safety of machinery. Basic concepts, general principles for design. Basic terminology, methodology)

Low voltage

- EN 60335-1 (Household and similar electrical appliances - Safety)
- EN 60335-2-103 (Particular requirements for drives for gates, doors and windows)

Various options

The following package options are available for the STA (CDO 100 Compact) operator:

All options listed below can be supplied with either the KE, KU and WGI manual override variants;

STA 1-10-24

STA 1-10-24 E

CDO100 1-10-24

CDO100B 1-10-30

CDO100B 1-7-45

CDO100B 1-10-24

CDO 100: 1:10-30

STAW 1-10-24 E

STAW 1-10-24

CDO-100 1-10-24

5. Installation

5.1 Preparation



Danger!

To avoid injury, the following points must be observed:

- The operator must be installed free of any tension.
- The operator must not move on the shaft.
- The design and subsurface of all components must be suitable for the forces encountered.



Warning!

To avoid damage to the operator and the door, the operator must only be fitted if:

- the operator is undamaged,
- the ambient temperature is $-20\text{ }^{\circ}\text{C}$ to $+60\text{ }^{\circ}\text{C}$,
- the altitude of the location does not exceed 1,000 m,
- a suitably rated mains protection device has been selected.

Before installation, ensure that:

- the operator is not blocked,
- the operator has been newly prepared after a lengthy storage period,
- all connections have been carried out correctly,
- the direction of rotation of the drive motor is correct,
- all motor protective devices are active,
- no other sources of danger exist,
- the installation site has been cordoned off over a wide area.



Information

The relevant instruction for the door must be observed when fitting the drive to the door.

- a suitably rated mains protection device must be selected.

5.2 STA Sectional Operator

Mounting with torque bracket - example

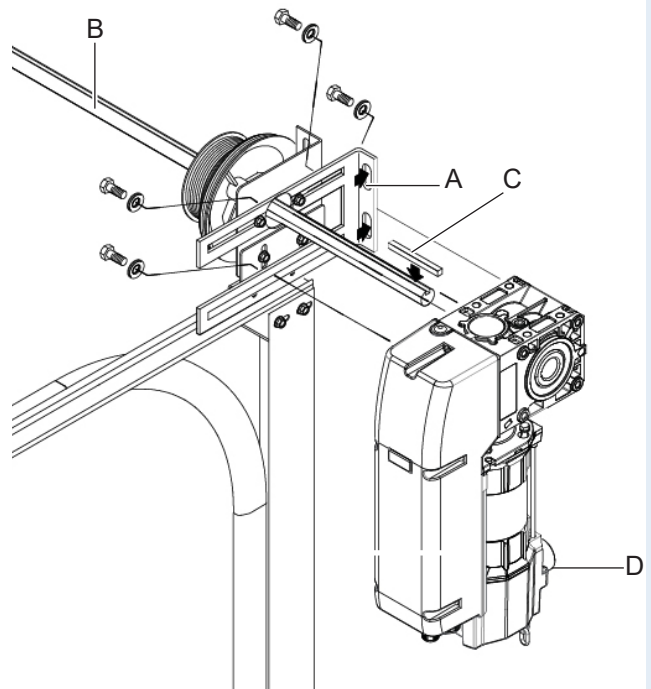

Fit the torque support bracket/console (A).
Grease the spring shaft (B) around the operator seating.
Insert the feather key (C) into the spring shaft (B).
Place the operator (D) on the spring shaft (B).
Secure the feather key (C) against any movement.

The feather key can be secured with two hose clamps or adjusting rings.

Fix the operator to the torque support bracket with 4 bolts.



Warning!

Damage due to improper installation the drive! To avoid damage to the drive and to the door, the drive must be mounted on a torque support bracket that is vibration damped.

5. Installation

Mounting torque support bracket to Operator

1. Remove Plastic caps (if fitted) from hollow shaft of the operator.
2. Fix torque plate using the 4-off M8x20 bolts, 4-off M8 spring washers and 4-off M8 flat washers.

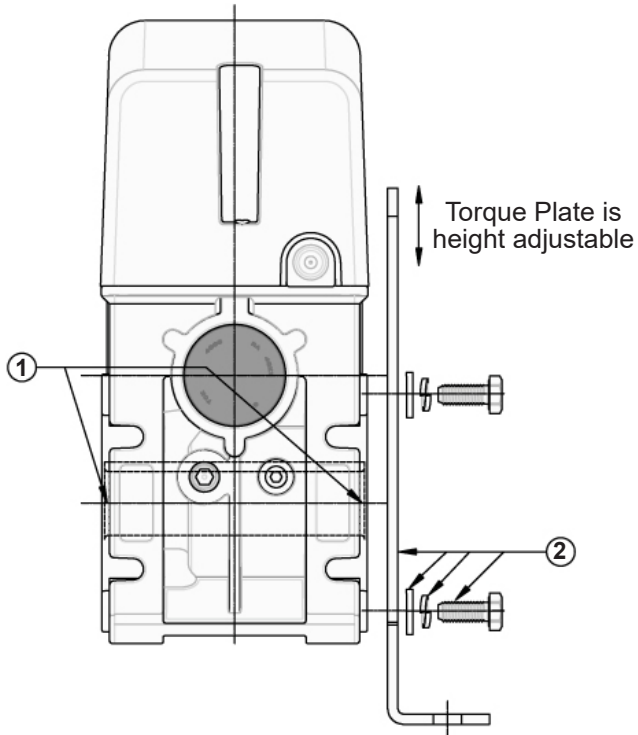

Information:

Marantec UK Ltd. constantly strives to improve the quality of its goods and as such reserves the right to replace/modify products without prior notification. Any examples given are intended for guidance only.

5.3 CDO100 Compact Operator - Flange Mount

Handing the operator

This operator is suitable for left or right hand installation. The flange and shaft can be removed and fitted on the opposite side.

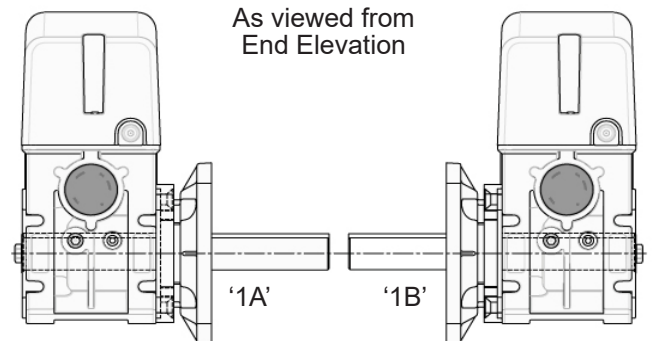

Assembly of the operator

1. Remove the plastic caps (if fitted from hollow shaft of the operator)

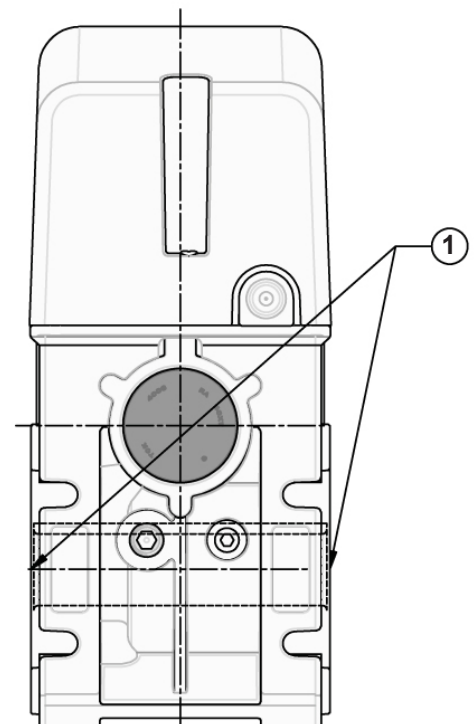

5. Installation

2. Ensure the keystone is secured in the keyway and fit the drive shaft ensuring that the shaft comes flush with hollow shaft on the non-drive side. The drive shaft is held by the M8x20mm bolt and washer (see step 1)

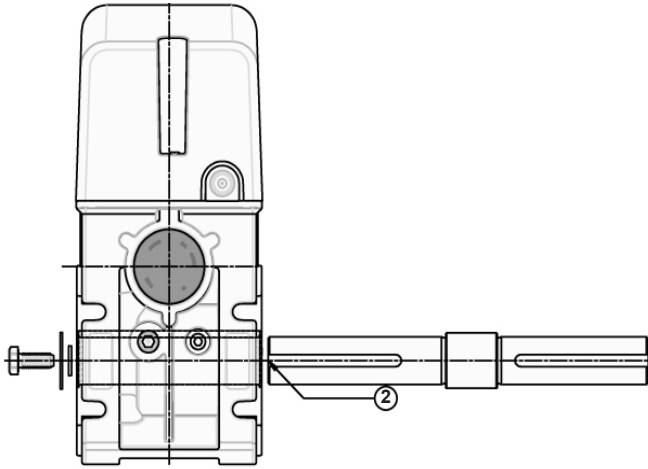

3. Fix the flange adaptor using 4-off M8x25mm countersunk socket cap screws.

4. Fix the flange using the 4-off M8x22mm socket cap screws.



Information:

The flange adaptor will only fit correctly in one orientation

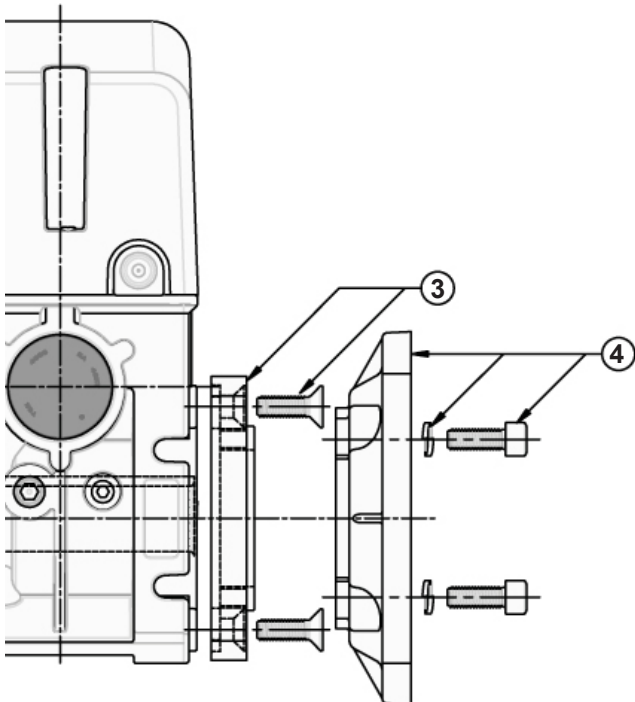

5. Ensure the keystone is secured in the keyway and fix the drive sprocket or gear pinion to the drive shaft

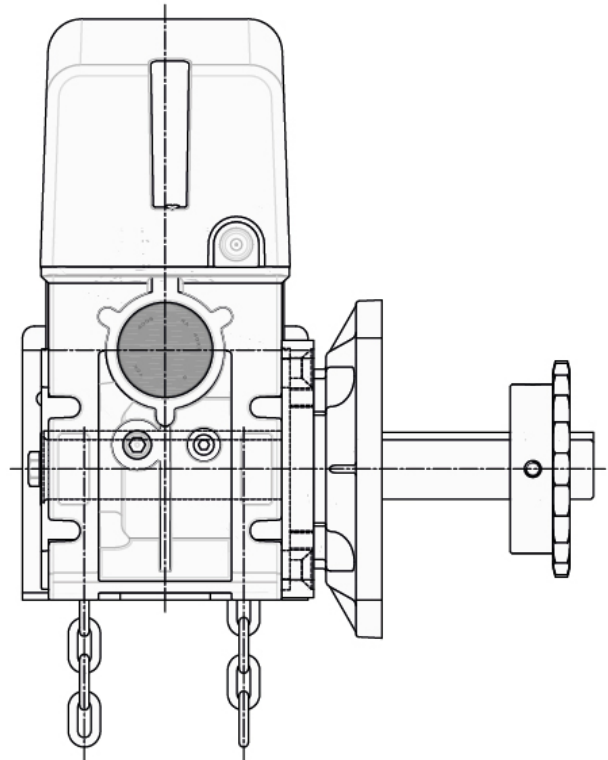

Warning!

Damage due to improper fixing of the sprocket / gear pinion. Fixing the drive sprocket at the end of the shaft may cause excessive loading on the shaft - resulting in shaft failure.- Ensure the keystone is secured in the keyway.

5. Installation

5.4 CDO100 Compact Operator - Foot Mount

Handing the operator

This operator is suitable for left or right hand installation. The shaft can be removed and fitted on the opposite side.

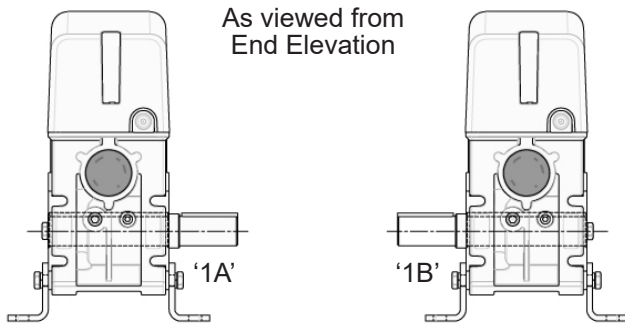

2. Ensure the keystone is secured in the keyway and fit the drive shaft ensuring that the shaft comes flush with hollow shaft on the non-drive side. The drive shaft is held by the M8x20mm bolt and washer.

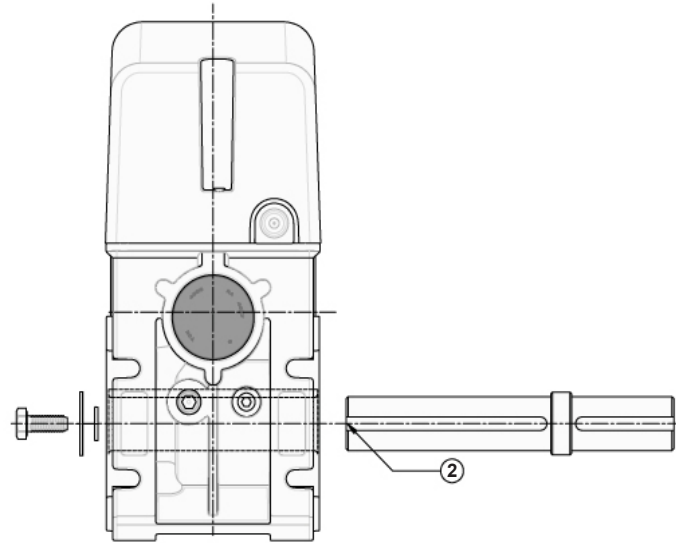

1. Remove the plastic caps
(if fitted from hollow shaft of the operator)

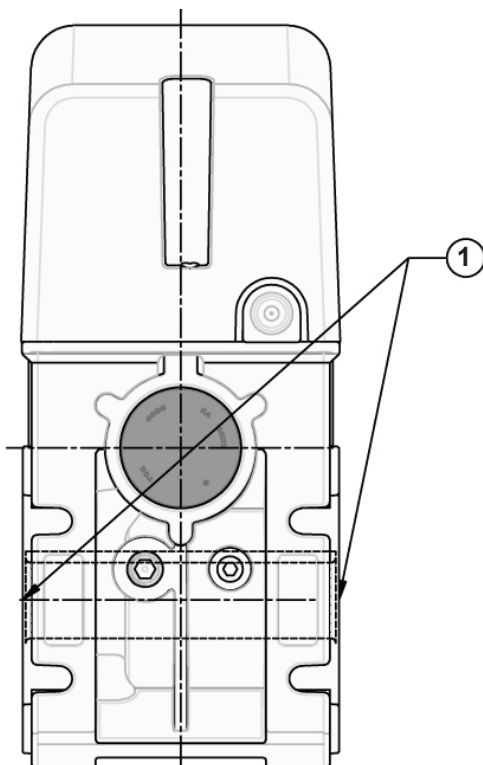

3. Fix each mounting foot using the 2-off M8x20mm Bolts and 2-off M8 spring washers.

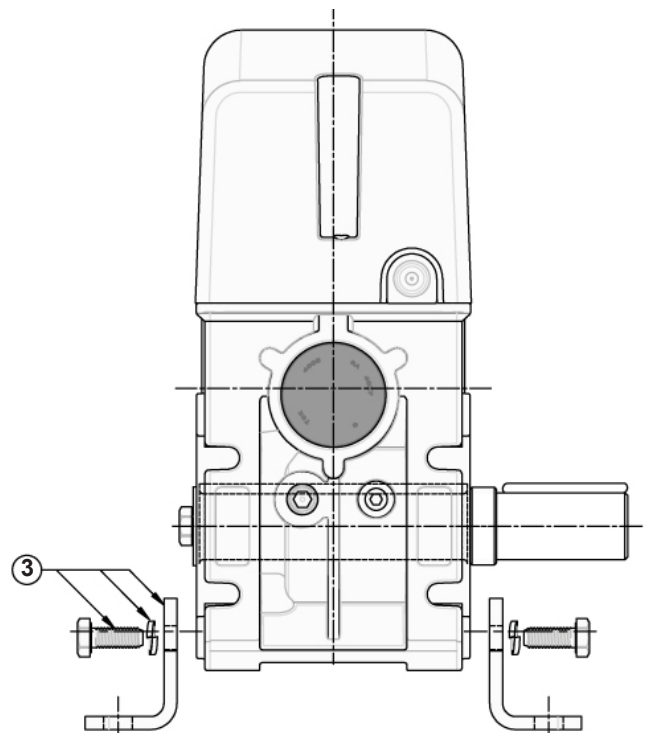

5. Installation

4. Ensure the keystone is secured in the keyway and fix the drive sprocket or gear pinion to the drive shaft

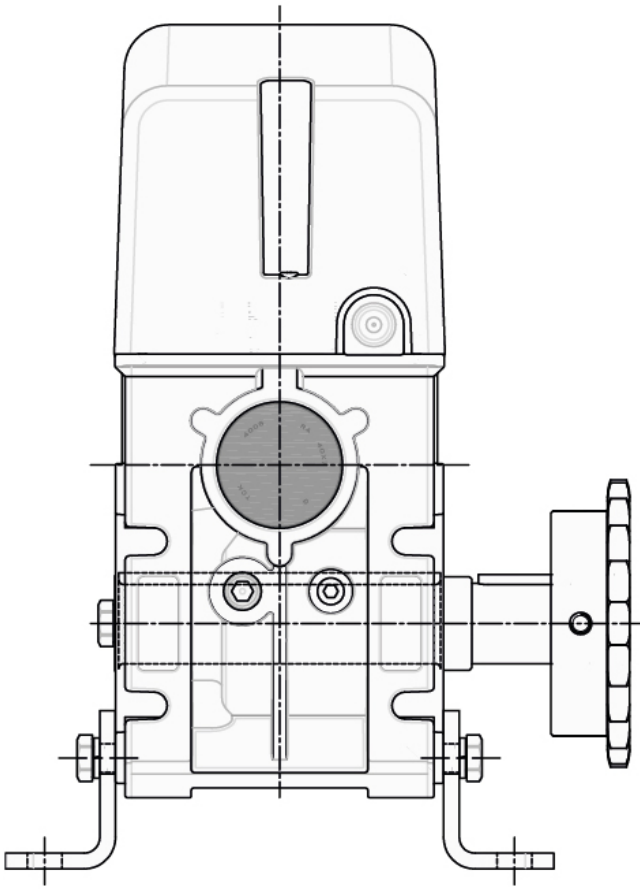

Warning!

Damage due to improper fixing of the sprocket / gear pinion. Fixing the drive sprocket at the end of the shaft may cause excessive loading on the shaft - resulting in shaft failure.

5.5 Installation of the emergency hand chain (for operators with emergency hand chain)



Information:

To ensure that they work correctly, the chain links must not be twisted.

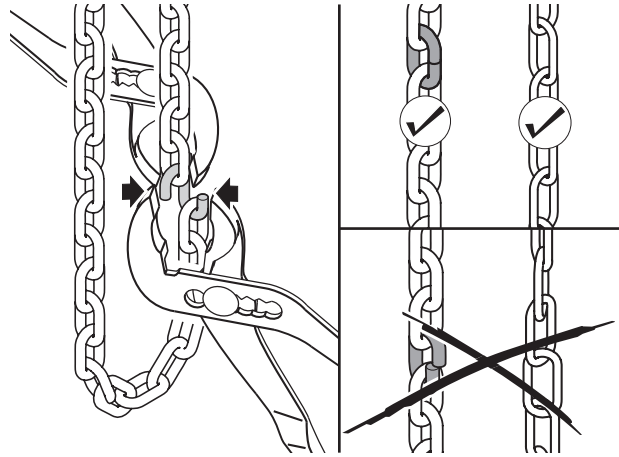

Join the ends of the emergency hand chain together with a chain connecting link.



Warning!

To avoid damage to the operator and the door, the emergency hand chain must be safely secured (for example in a 'chain keep') while the door is operated electrically.

6. Initial Operation

6.1 Preparation



Warning!

To avoid damage to the operator, the following points must be observed:

- The types of cable and their diameters must be selected according to current regulations.
- The nominal currents and the type of connection must correspond to those on the motor type plate.
- The drive details must agree with the connected loads.



Information:

When operated with electronic control units, the corresponding start-up instructions and circuit diagrams must be complied with.

6.2 Motor & Limit Switch Connections

Open the operator

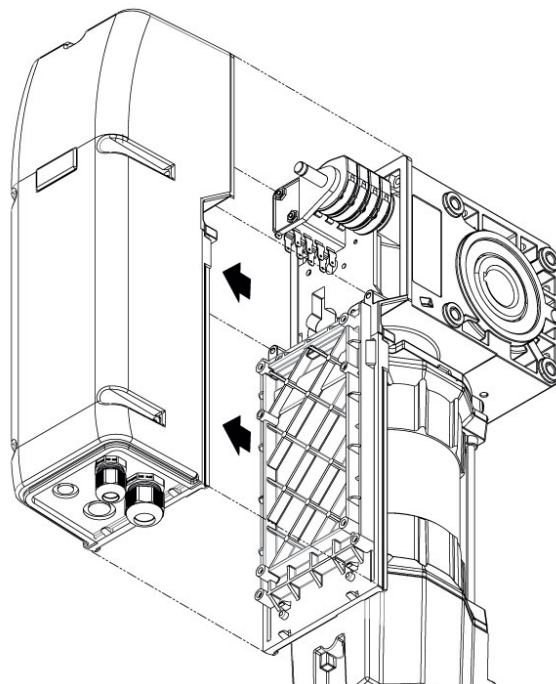

Remove the cover from the operator.

Insert the cables

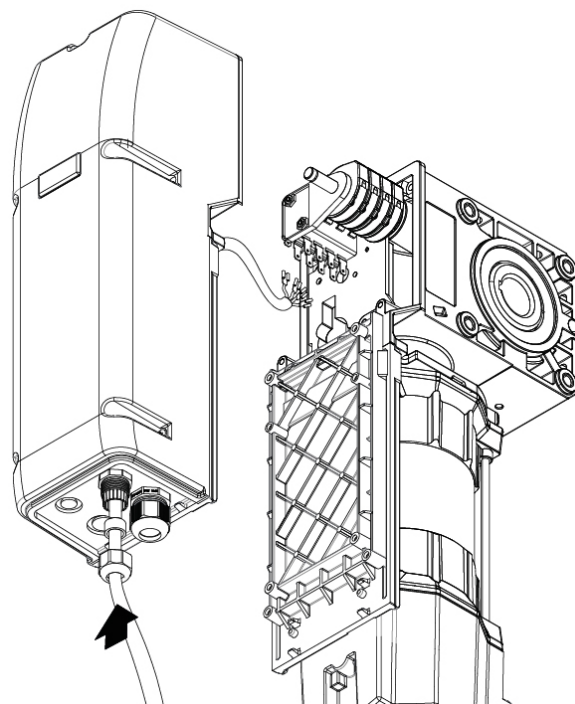

Feed the cables through the gland fitting into the operator.

6. Initial Operation

Limit switch connections (microswitches)

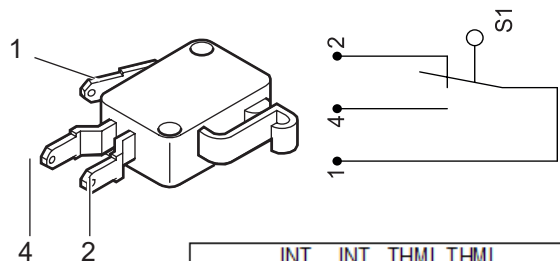
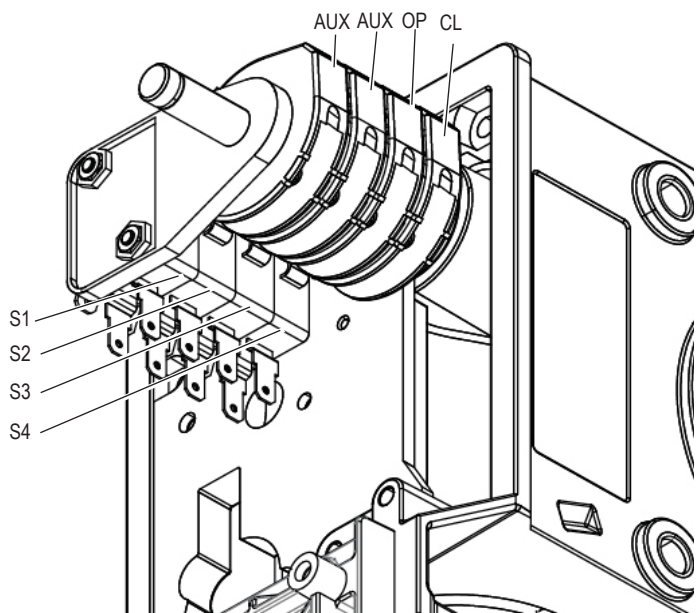

Internal Pre-wired Connections

- A Motor - "U", "V" & "W"
- B Thermal Switch - N/C
- B2 Interlock Switch - N/C
- C Limit Switch Cables

Customer Connections

- D Motor Supply Connections "1", "2" & "3"
- E Limit Switch Connections:
 - "6" - Common
 - "7" - Open Limit
 - "8" - Close Limit
 - "9" - Pre-Close Limit
- F Thermal / Interlock Connections "4" & "5"
- G Cap Switch Option Wiring
- H Cap Switch Connections "10" & "11"

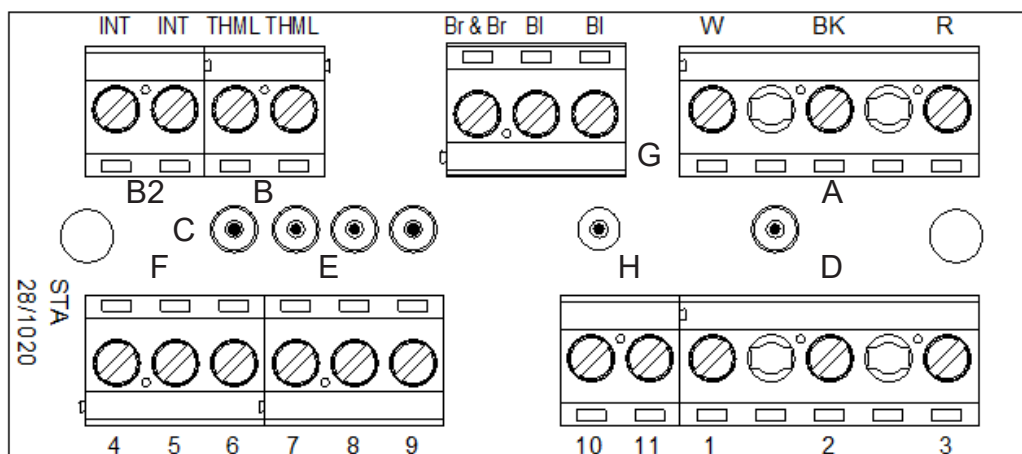

3-Wire



CS-250

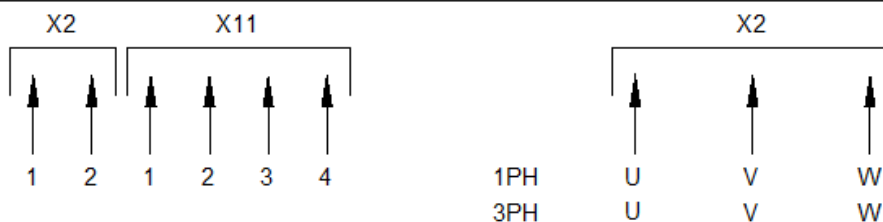

CS-310

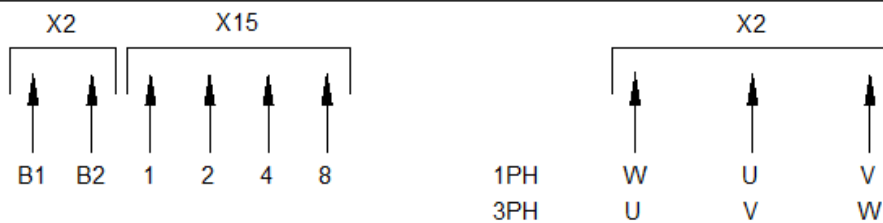

6. Initial Operation

MOTOR - 3 x 400V star connection (standard)

The motor is factory-wired for connection to a 3 x 400V mains supply control panel.

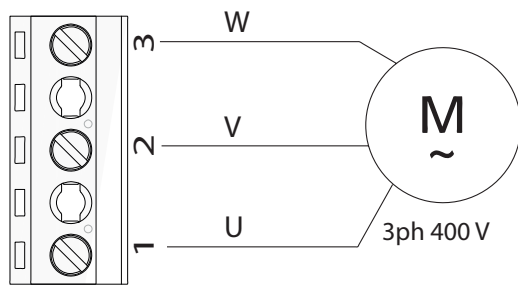

Connect all the cables required

MOTOR - 3 x 230V delta connection

To connect the operator to a 3 x 230V mains supply, please consult the manufacturer.

MOTOR - 1 x 230V connection

The motor is factory-wired for connection to a 230V/1-phase mains supply control panel.

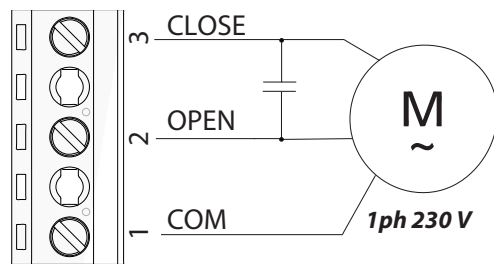

Connect all the cables required.

Pre-wired cable connections (12 core cable)

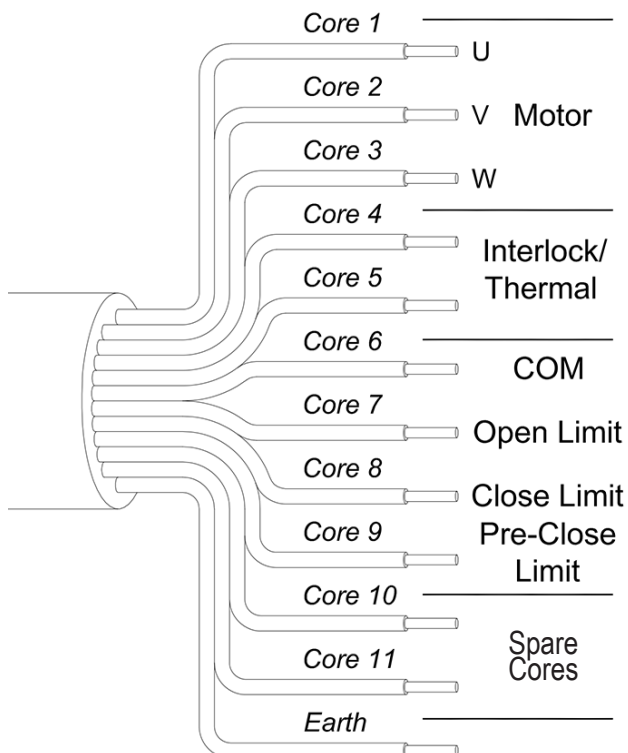

6.3 Setting Mechanical Limits

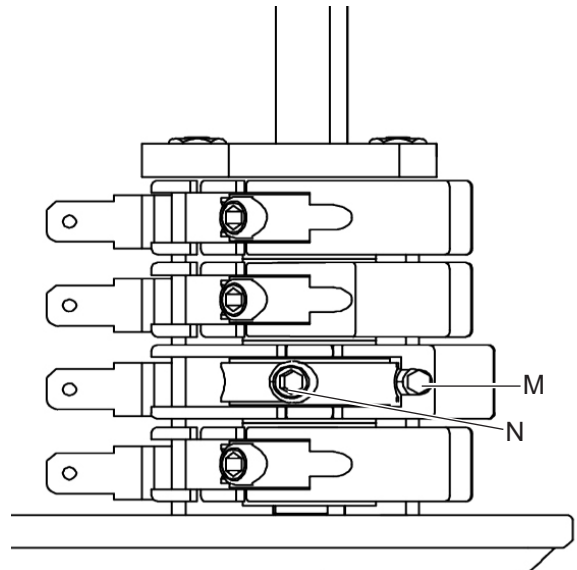

M Fine adjustment screw
N Locking screw

Each control cam has a locking screw (N) and a fine adjustment screw (M).

The locking screw (N) is used to lock the corresponding control cam in the desired position. Finer adjustment can be made with the fine adjustment screw (M).

Set the CLOSED end position

Drive the door to the CLOSED end position.
Set the control cam so that the CLOSED limit switch (S4) is actuated.
Tighten the locking screw (N).

Set the OPEN end position

Drive the door to the OPEN end position.
Set the control cam so that the OPEN limit switch (S3) is actuated.
Tighten the locking screw (N).



Warning!

To avoid damage to the operator it is important that all unused cams **MUST** be locked in position

6. Initial Operation

6.4 Digital Limits

Electronic interface

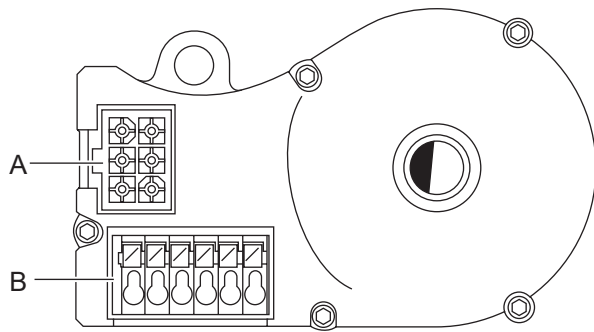

- A: AVE plug (absolute value encoder plug)
B: AVE plug terminal (absolute value encoder plug terminals).



Information:

Please refer to the control unit operating manual for instructions on setting the limit end positions.

Wiring allocation, AVE (absolute value encoder) plug

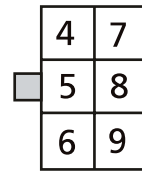

The numbers on the plug are also the wire numbers.

- 4: Safety circuit input (N/C)
5: RS 485 B
6: GND
7: RS485 A
8: Safety circuit output (N/C)
9: 7...18V_{DC}

AVE (absolute value encoder) plug terminal (7-12)

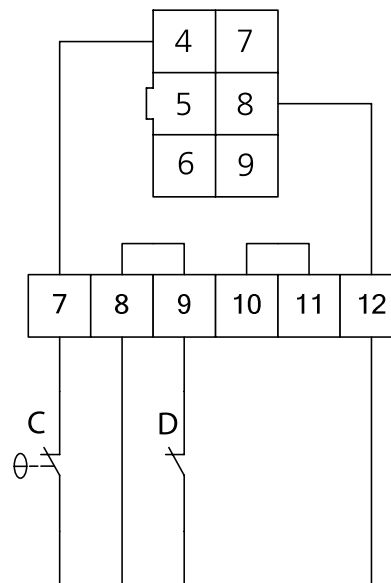

- C: Thermal element in the drive
D: Manual emergency control (emergency crank or emergency chain)

6.5 Check the system

Check the direction of travel

Drive the door in the CLOSED direction.
The operator must close the door.

Drive the door in the OPEN direction.
The operator must open the door.



Information:

If the door's direction of travel does not correspond to the commands keyed in, then the direction of rotation must be changed. Instructions for changing the direction of rotation are given in the control unit operating manual.
After this the direction of travel must be checked again.

Check the limit switch settings

Drive the door to the CLOSED end position.
The operator must stop in the desired position.

Drive the door to the OPEN end position.
The operator must stop in the desired position.

Check the mechanical functions

After assembling and installing all components the functions of the system must be checked.

Check that all mountings have been securely tightened.

Check all the functions of the system.

Check that the operator runs smoothly.

Check whether the operator is leaking oil.

If the operator makes unusual noises or leaks oil:

- The operator must be taken out of service immediately,
- Contact technical support.

Danger!

To avoid injury, the following points must be observed:

- Emergency operation may only be carried out from a safe standing position.
- Emergency operation may only be carried out when the motor is stationary.
- The system must be disconnected from the power supply during emergency operation.
- Operators with a spring brake must be actuated against the closed brake when opening or closing the door.
- For safety reasons, brakes in doors without a weight counterbalance must only be released in the closed door position for testing purposes.
- Accidental releasing of the brake must be rendered impossible by preventive measures at the installation site.

During maintenance works or in the case of an electrical failure, the door can be moved towards the OPEN or CLOSED positions with the help of the emergency manual override equipment.



Information:

If the door is moved beyond the CLOSED or OPEN end positions, the operator can no longer be activated electrically

- place the door back into a normal position before attempting powered operation.

7. Emergency Operation

Operation with emergency hand chain

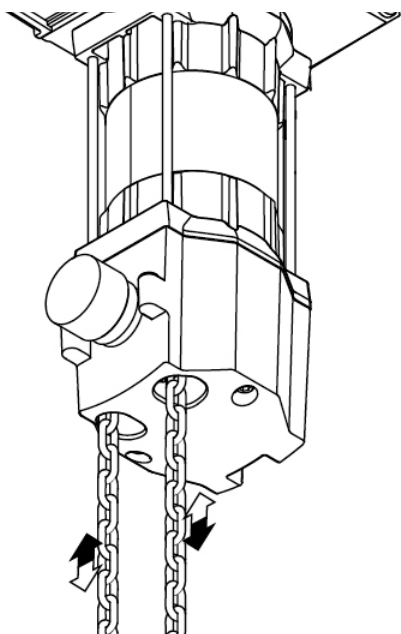

- Release the emergency hand chain from its fixing.
- Move the door in the OPEN or CLOSE direction by pulling on the emergency hand chain on the side concerned.

Operation with emergency hand crank

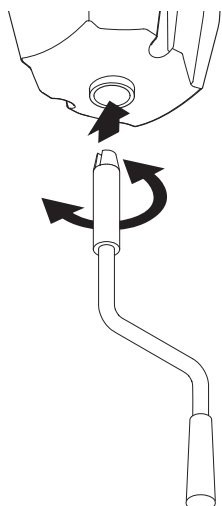

- Push the emergency hand crank into the operator as far as it will go.
- Move the door in the OPEN or CLOSE direction by turning the emergency hand crank.
- Remove the emergency hand crank from the operator after completing emergency manual operation.

Operation with emergency wheel guide & interlock

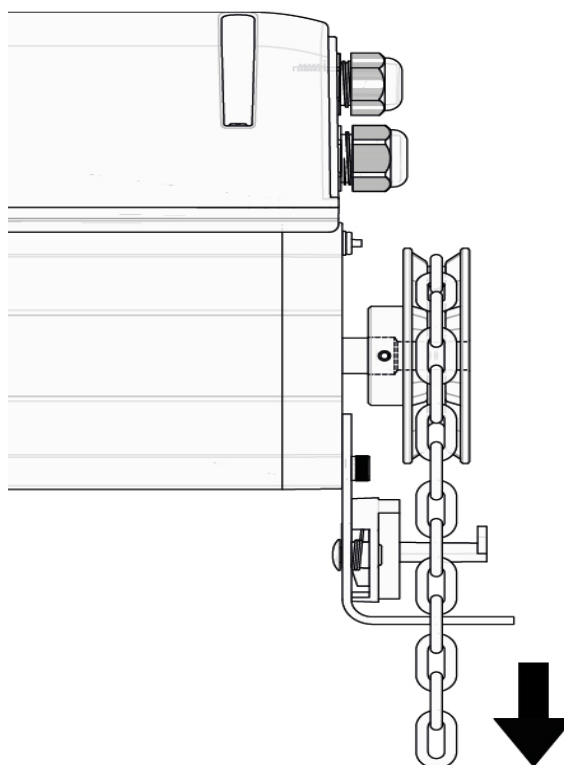

Lift the handchain off the safety switch and place it on the chainwheel.

The Door can now be operated by handchain. Before power is restored, the above procedure must be reversed

Operation with disengage mechanism



Warning!

To avoid injury, the following points must be observed:-

- Drive units with a disengage mechanism require that a fall protection is mounted on to the door.
- Without a fall protection the door does not comply with directive ASR. A1.7 and may fall in an uncontrolled manner

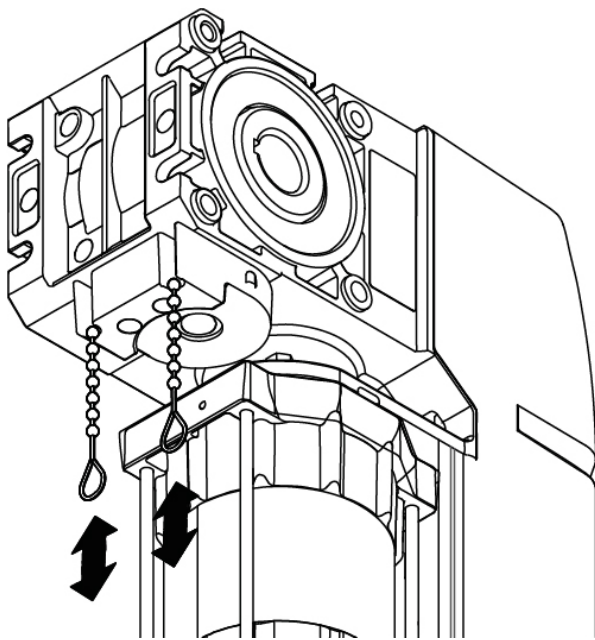

Pull on the red loop.

The door can be moved manually.

Pull on the green loop.

The door can be moved with the operator.



Warning!

To avoid damage to the operator and door, the following points must be observed:

- Maintenance must only be carried out by authorized persons.
 - Directive BGR 232 must be complied with.
 - Worn or faulty parts must be replaced.
 - Only approved parts may be installed.
- All maintenance work must be documented.



Information:

The drive unit has lifetime lubrication and is maintenance-free.

Check that all mountings have been securely tightened.

Check the brake (if available).

Check the limit switches and safety switches.

Check for noises and oil leaks.

Check the mounting of the operator for corrosion.

Check the housing for damage.

Authorised Distributor:
Marantec UK

EC Declaration of Incorporation

Manufacturer:

MFZ Antriebe GmbH & Co. KG, Neue Mühle 4, D-48739 Legden

We hereby declare that the products described below:

Sectional door drive STAC1-E, STAC1-KU and STAC1-KE

are in conformity with the essential requirements of the Machinery Directive (2006/42/EC).

In addition, the partly completed machinery is in conformity with all the provisions of the EU Construction Products Regulation No. (305/2011/EC), the Electromagnetic Compatibility Directive (2014/30/EU) and the Low Voltage Directive (2014/35/EU).

The following standards were applied:

EN 60204-1	Safety of machinery, electrical equipment of machines – Part 1: General requirements
EN ISO 12100	Safety of machinery - General principles for design – Risk assessment and risk reduction
DIN EN 12453	Industrial, commercial and garage doors and gates – Safety in use of power operated doors – Requirements
DIN EN 12604	Industrial, commercial and garage doors and gates – Mechanical aspects - Requirements
DIN EN 61000-6-2	Electromagnetic compatibility (EMC) - Part 6-2: Generic standards – Immunity standard for industrial environments
DIN EN 61000-6-3	Electromagnetic compatibility (EMC) - Part 6-3: Generic standards – Emission standard for residential, commercial and light-industrial environments
DIN EN 60335-1	Household and similar electrical appliances - Safety – Part 1: General requirements
DIN EN 60335-2-103	Household and similar electrical appliances - Safety – Part 2-103: Particular requirements for drives for gates, doors and windows

The relevant technical documentation is compiled in accordance with Annex VII(B) of the Machinery Directive (2006/42/EC). We undertake to transmit, in response to a reasoned request by the market surveillance authorities, this documentation in electronic form within a reasonable period of time.

The authorised agent for the preparation of the technical documentation is: MFZ Antriebe GmbH & Co. KG, , Neue Mühle 4, D-48739 Legden

The machinery is incomplete and must not be put into service until the machinery into which it is to be incorporated has been declared in conformity with the provisions of the Machinery Directive (2006/42/EC).

Place / Date

Legden, 20/04/2016

Manufacturer's signature



Dirk Wesseling

Position of signatory:

Management



DHF

Door & Hardware
Federation

Door & Gate Operators, Access Control & Security Equipment

Registered in England & Wales No. 2525292



Certificate Number 1149
ISO 9001

Marantec UK Ltd. reserves the right to change / modify products without prior notification