

**Important Information**

**General**

THE SG 16 LIGHT CURTAIN SHOULD ONLY BE INSTALLED BY AUTHORIZED AND FULLY TRAINED PERSONNEL!

THE LIGHT CURTAIN IS ONLY A SAFETY PROTECTION DEVICE IF ALL INSTRUCTIONS IN THIS MANUAL, ARE CAREFULLY FOLLOWED AND FULLY COMPLIED WITH. IN ADDITION, THE INSTALLER IS REQUIRED TO COMPLY WITH ALL LOCAL LAWS AND STANDARDS.

ANY ALTERATIONS TO THE DEVICE BY THE BUYER, INSTALLER OR USER MAY RESULT IN UNSAFE OPERATING CONDITIONS.

**Compliance to Directives and Standards**

"This device complies with the European directives, 2006/42/EC for machinery, 2014/30/EU for electromagnetic compatibility, when used in accordance with the instructions in this manual. Furthermore, the device complies with the European RohS directive 2011/65/EU.

The compliance to the directive of machinery is declared according to:

EN 12978  
 EN 13849-1 category 2, PL d  
 EN13849-2  
 EN12453

EC type examination:  
 TÜV NORD CERT GmbH, Am TÜV 1, 45307 Essen (NB 0044)  
 EC-type certificate No. 44 205 13 099406"

**Product Data**

**Technical Data**

	SGT (Transmitter)	SGR (Receiver)
Supply voltage	10-30 Vdc	
Max. Voltage ripple	15% (within supply range)	
Reverse polarity protected	Yes	
Max. current consumption	70 mA (RMS)	35 mA
Output	-	5V 900Hz square signal
Max. output load	-	2 KΩ
Max. capacitive load	-	100nF
Short circuit protected	-	Yes
Inductive load protection	-	Yes
Sensing range	1 m – 12 m	
Response time (max.) (*)	40 ms	

(\*) Independent on model

**Environmental Data**

Light immunity @ 5° incidence	> 100.000 lux
Temperature, operation	-25 to + 55 °C
Temperature, storage	-40 to + 80 °C
Sealing class	IP67

**Marking**



**Available Models**

	Model	OSE output type	Sensing Range
Transmitter	SGT 16-xxx-0xx-X1-U-0x-xx	-	0 – 12m
Receiver	SGR 16-xxx-xxx-x1-U-OSE-xx-xx	5V 900Hz square signal	

**Connection**

**Wiring Diagrams**

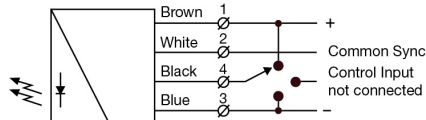

Transmitter SGT 16

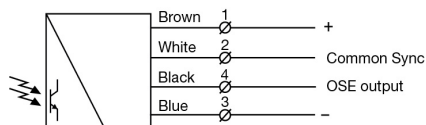

Receiver SGR 16 OSE output

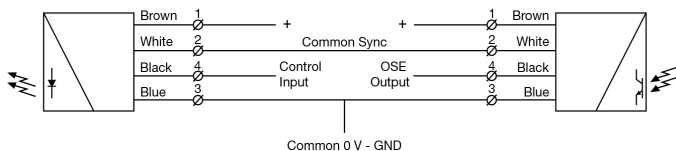

SGT 16 and SGR 16 OSE with common 0V – GND and synchronization wire

**SGR Output Logic**

Detection	Output status	Output indicator (yellow led)
Present 	0V	Off
Absent 	5V 900 Hz square signal	On

**Installation & Adjustment**

**General Instructions and Precautions**

This light curtain can be used in industrial, commercial and garage doors and gates, as described in EN 12453, with a minimum level of safeguarding E. There are various ways of mounting the light curtain. In any case it is important to ensure that the requirements from EN 12453 are met.

The dynamic blanking allows the light curtain to be mounted in the door plane of vertically sliding doors, where the door is passing through the beams in a movement up and down. It is important that the lowest part of the door leaf will efficiently obstruct the light beams over a height of 50 mm.

Even though the light curtain has a high degree of immunity to ambient light sources, it is recommended to avoid direct exposure to sunlight and interference from flashlights or other infrared light sources (such as other photoelectric sensors).

If the front cover or the opto components of the light curtain become contaminated, then they have to be cleaned with a slightly damp cloth. Do not use organic solvents or detergents.

Ensure that the light curtain is mounted so that it is mechanically stable during operation. Severe rain and snow may be detected due to the high sensitivity of the system.

Automatic door closure must be disabled on the door controller if door repair or maintenance or other activities requires longer presence in the door opening. In general, do not prevent automatic door closure by placing objects in the active area of the light curtain.

**SG 16 Master/Slave Configuration (installation of double light curtains)**

It is possible to mount 2 light curtains in line with thick and heavy doors. Another possibility is to install one set on each side of the door.

The two light curtains sets must then have a common 0V - GND, + supply and synchronisation connection as shown below.

The polarity's connection defines the Master set and the Slave set. The set connected with the standard polarity will act as Master set. And the set connected with the reversed polarity will act as Slave. A SG 16 set connected as a slave (reversed polarity) will not run without connection to a SG 16 Master set.

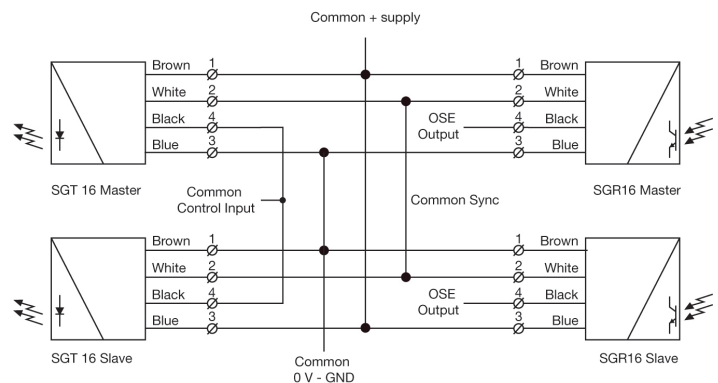

SG 16 OSE Master/Slave wiring

**Indicators**

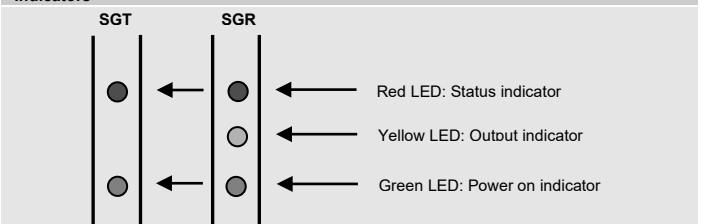

**Installation and Adjustment**

No initial set up or adjustments are required, due to the automatic signal-tracking (AST) feature, which automatically adjust each individual channel on the system.

- Mount the transmitter (SGT) and receiver (SGR) facing each other and correctly aligned. The bottom beam is 35 mm above ground if the rails stand on the ground on the pin. The pin can partially or completely be cut off if the light curtain needs to be lowered relative to support structure.

2	Fix the mounting clips in line and parallel. The maximum distance between the points of fixture should not exceed 135 cm.
3	Wire transmitter and receiver according to the wiring diagram. Make sure the load does not exceed 100 mA.
4	Check for correct wiring.
5	Turn power on.
6	When the power on indicators (green LEDs) is on, the system is operating. No initial set up or adjustments are required.

**SGT Control/Test input**

How the control/test input is to be operated depends on digit **0X** in the model code for the transmitter (SGT);

SGT 16-xxx-0xx-X1-x-**0X**-xx

The test is enabled and disabled via the black SGT control wire. (See "Wiring Diagrams" and table above). Make sure no object is present in the detection area when test is done.

In a Master/slave configuration connect the two SGT control wires together so the tests are activated simultaneously on the SGT master and SGT slave.

Model Transmitter SGT	Control/Test input connected to 0V - GND	Control/Test input not connected	Control/Test input connected to + supply
00	Testing activated	No testing	No testing
01	Testing activated	No testing	Testing activated
02	No testing	Testing activated	No testing
03	No testing	No testing	Testing activated
04	Testing activated	Testing activated	No testing

**SGT/R Test Input Response Time**

Ton (max./min.)	Toff (max./min.)	Tr (max./min.)
150 ms / 20 ms	60 ms / 1 ms	500 ms / 100 ms

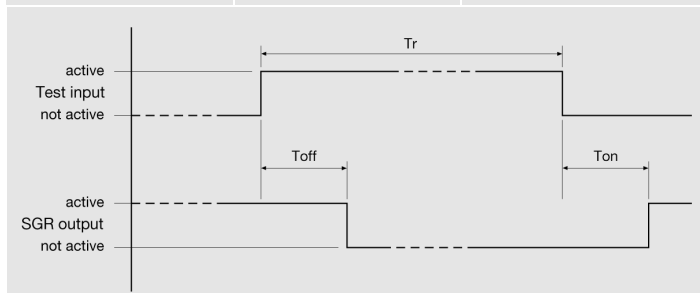

SGT/R test input response time graph

**Housing Length and Number of Channels**

Housing length	Beam Placement	Active Height	Number of channels
1970 mm	C1	1800 mm	41
	D1	1800 mm	29
	F1	1800 mm	20
2150 mm	C1	1980 mm	45
	D1	1980 mm	30
	F1	1980 mm	21
2330 mm	C1	2160 mm	49
	D1	2160 mm	31
	F1	2160 mm	22
2510 mm	C1	2340 mm	53
	D1	2340 mm	32
	F1	2340 mm	23

**Dynamic Blanking Function**

**Dynamic Blanking Function**

All the infrared light beams can be blanked out (made inactive) without changing state of the output of the receiver by moving a non-transparent object between the SGR and SGT from top of the rails to the lowest beam.

In order for the blanking process to function correctly, it is recommended that the blanking object has a minimum vertical height of 50 mm and enough width to ensure that the front window of the light curtain is fully covered during the closing process. Beams are blanked in (activated) when the door motion is reversed.

The output will go to 0V 3 s after the lowest beam is broken.

The light curtain supports partial opening of the door, for energy saving or ventilation. However, notice that the stop either has to be in the zone with 45 mm beam spacing or then the bottom part of the door leaf has to obstruct the beams over 200 mm, keeping the lowest beam obstructed when stopped. This limitation exists for safety reasons; the light curtain shall not respond with permanent blanking of beams for objects just passing through the beams and thereafter taken out of the active zone.

All beams will stay blanked, as long as the lowest beam, at the bottom of the rails is obstructed. Make sure that the lowest beam is kept well obstructed, when door has finished closing. The blanked beams are ignored by the output logic.

Maximum door closing speed	1.6 m/s
----------------------------	---------

There is no restriction on maximum speed when the door is opening.

When a blanking object of 50 mm vertical height is passing areas with 180 mm beam spacing, the minimum speed of the blanking object is 0.18 m/s. There is no minimum blanking speed if the blanking object has a size so that at least one beam is always obstructed.

If the door leaf is stopped between the rails before the bottom (lowest) beam is reached and 3 or more beams above the door edge are not obstructed, the output will switch to a safe state after 2 seconds for a SG 16 with C1 beam placement and 4 seconds for D1 and F1 beam placement.

**Notice that the actual speed of the bottom door edge can fluctuate for a non-rigid door construction and it is advised that the door speed has to be set below 1.6 m/s in order not to exceed the maximum speed limit of the light curtain while the door is closing.**

**Be aware that side to side movements of a round bottom door edge will also contribute to the fluctuation of the obstruction speed. It is therefore best to have a horizontal straight edge for obstruction of the light beams.**

**Static Blanking Function**

**Static Blanking Function C1 beam placement only**

The static blanking function allow the user to make a number of beams permanently inactive.

Notice this is only possible for a light curtain with beam placement C1, where all beams have 45 mm distance between them. Static blanking can not be done in a master/slave configuration setup with two light curtain sets. If this is needed then do static blanking on each separate set (only one SGR and SGT rail connected) an afterwards connect the two sets in master/slave configuration.

The beams can be blanked out statically both in the top and/or in the bottom of the light curtain. However, the statically blanked area will have to go from the top beam and down in a coherent area, and/or from the bottom beam and up in a coherent area. There can be no active beams inside these areas.

The total number of beams that can be statically blanked out is maximum 2/3 of the total number of beams.

Static blanking requires a special blanking procedure. Any deviation from this procedure will lead to lack of static blanking and previous function will resume.

1. Obstruct **all beams** in the areas that needs to be statically blanked.
2. Remove power from the light curtain.
3. Activate the control input on SGT16 (how to do, depends on model)
4. Power the light curtain up. Green LED on SGR16 will flash for 4 s.
5. De-activate control input when Green LED stops flashing. This has to be done within 2 s.
6. If de-activation is done correctly, red, yellow and green LEDs on SGR 16 will flash simultaneously 3 times showing static blanking is done correctly.
7. **Check that the desired beams are made inactive and all other beams are functioning as intended.**

The beams are permanently made inactive also after power down. Only a new static blanking procedure will change the number of active beams. If the number of beams obstructed are more than 2/3 of all beams or if the obstructed areas are not as specified or if the light curtain has a free beam in the obstructed areas or if the test procedure is not done exactly in accordance with point 1 – 7, then there will be no static blanking.

In that case the light curtain will resume function with the latest legal static blanking.

**Troubleshooting**

Troubleshooting	
Probable Reason	Corrective Action
1. Symptom: Red LED on SGT is constant on. Hardware failure	Replace the SGT rail.
2. Symptom: Red LED on SGR is constant on. Hardware failure.	Replace the SGR rail.
3. Symptom: Yellow LED on SGR is flashing. Cross talk from another light curtain or other powerful light sources. SGR and SGT rails are not aligned.	Change position of the SGT and SGR rails. Align the SGR and SGT rails.
4. Symptom: Yellow LED on SGR is constant off. Red LED is off. Control/test input on SGT is constant activated, or beam is obstructed, or light curtain out of range, or transmitter is off, or lack of sync connection.	Deactivate the control/test input on SGT, remove obstruction, bring light curtains closer or improve alignment, turn on transmitter, connect white sync wire.
5. Symptom: After power-up red LED on SGR keep blinking. Yellow LED on SGR is off. Control/test input on SGT is constant activated, or beam is obstructed, or light curtain out of range, or transmitter is off, or lack of sync connection.	Deactivate the control/test input on SGT, remove obstruction, bring light curtains closer or improve alignment, turn on transmitter, connect white sync wire.

<b>Disposal</b>
-----------------

<b>Disposal</b>
-----------------

Disposal should be done using the most up-to-date recycling technology according to local rules and laws.
---

<b>Manufacturer</b>
---------------------

<b>Manufacturer</b>
---------------------

Telco A/S Vangen 5, DK-9460 Brovst, Denmark
--