

WIRELESS VEHICLE DETECTOR

TOSBA

User Manual V2.2

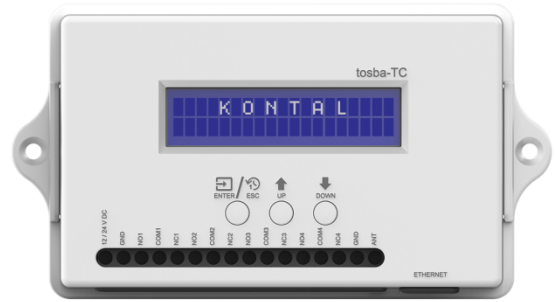



Please read the user manual carefully before using your device. Pay attention to the installation, electrical connection and initial start sections and follow the specified steps. The product owner/user should keep this user manual in a known and visible place throughout the life of the product.

- This product can be used indoors and outdoors. For outdoor use, the installation must be done correctly.
- Batteries are not covered by the warranty in battery operated products. In products whose shelf life has expired, malfunctions caused by battery liquid discharge or leakage are not covered by the warranty.
- All service and repairs can only be done by Kontal Elektronik. The product should not be intervened by any other persons.
- The operating voltage of the product is described on its label. Do not power the product with a different source outside this voltage range.



If the product is used in violation of the above-mentioned items, it may cause fire, personal injury, or damage to the product or the structure in which the product is installed. Kontal Elektronik Ltd does not accept any responsibility for such situations caused by the user.

- ✓ This exclamation mark will be used to highlight important points.



Do not touch supply input of the product with bare hands.

- ✓ This electric mark will be used to highlight electricity hazard.



- ✓ This sign on the label indicates that the supply voltage of the product is DC.



This symbol on the product or its box indicates that this product cannot be treated as normal household waste. Instead, the product should be delivered to designated collection points for the recycling of electronic equipment. Incorrect disposal of the product can have negative consequences for the environment and human health.



Legal rights and responsibilities of this document and its revisions belong to Kotal Elektronik Ltd. It is illegal and prohibited to change it without permission.

1. DEFINITION

The Wireless Vehicle Detection System consists of a controller and transmitter sensors defined in the controller's memory. It is generally used to detect whether a vehicle is located at the desired location on the ground during automatic opening and closing of barriers in parking lots and residential site entrances or automatic ticket issuance. In addition, it is also used in industrial doors, rising bollards systems and high speed PVC doors. The transmitter sensor, which will be fixed on the ground, communicates with the controller by detecting the density of the metal that will come on it, and the desired device is controlled by the relay or relays on the control card.

2. TECHNICAL FEATURES

TECHNICAL FEATURES

Model	: TS 1P / TS 2P
Product Code	: K185-01 / K203-01
Battery Type	: 3,6V DC *
Working Frequency	: 433,92MHz
Output Power	: ~0,06W
Max. Current	: 17mA
IP Class	: IP68
Working Distance	: <35m**
Working Temperate	: -25 °C +55 °C
Weight	: 1128 gr. / 1178 gr.
Dimensions (Width x Length x Depth)	: 245 x 245 x 37mm

Model	: TC
Product Code	: K186-01
Working Voltage	: 12/24V DC
Working Current	: 81mA@24V
Working Frequency	: 433,92MHz
Contact Type	: Kuru Kontak NO/NC
Max. Contact Power	: 250V 5A
Transmitter Sensor Capacity	: 8
Working Temperate	: -25 °C +55 °C
Weight	: 174 gr.
Dimensions (Width x Length x Depth)	: 84 x 155 x 33mm

- **TS:** TOSBA SENSOR (TRANSMITTER SENSOR), **TC:** TOSBA CONTROLLER (RECEIVER CARD, CONTROL CARD)
- **TS 1P:** 1 BATTERY TOSBA SENSOR, **TS 2P:** 2 BATTERY TOSBA SENSOR

*TS 1P works with a single battery and operates for approximately 4 years in continuous mode, with an average of 1000 vehicle passes per day. In pulse mode, it works for about 5 years. TS 2P works with two batteries and operates for approximately 8 years in continuous mode with an average of 1000 vehicle passes per day. In pulse mode, it works for about 10 years.

**Working distance may vary depending on the environment and weather conditions in which the product is used.

- When the battery of the transmitter sensor is low, a warning will appear on the receiver card screen at regular intervals and the buzzer will beep to notify this situation. In this case, the battery of the sensor needs to be replaced.



The battery used to power the transmitting sensor is not rechargeable.
The battery used can also be changed by those who assemble the product, have knowledge about the product, read the user manual.

System Startup

This product is sent to you with the transmitter sensor disabled. No vehicle will be detected by the sensor. When you teach the sensor to the receiver, it will start detecting metal density and become active. To deactivate the sensor again, you need to go to the setting menu on the receiver and delete the sensor.

3. WIRELESS VEHICLE DEDECTOR SYSTEM AND USAGE

Wireless vehicle detector is an access control device used in vehicle detection especially in parking lots and barrier systems. The control of this system is made by the control card (TC) and the transmitter sensors (TS) defined in its memory. Using the LCD screen and buttons on the control card, many operations can be performed from the options defined in the system.

3.1. System Communication

Wireless vehicle (metal) detector consists of a control card (TC) and transmitter sensors (TS) registered in the memory of this card. The communication between the control card and the transmitters is transceiver (two sided). In this communication, the transmitter sensor (TS) detects an oncoming vehicle (metal) and sends data to the control card. Then it waits for a response from the control card (TC) that the information has been received. If there is a response, it continues its normal operation, if there is no response from the controller, it continues to send data to indicate that there is a vehicle on it. This process will continue as long as there is a vehicle on the transmitter sensor.

3.2. Wireless Vehicle Detector System Settings

In the wireless vehicle detector system, there are LCD screen and buttons on the control card (TC) that will allow various settings to be made. By using these buttons, settings such as teaching/deletion of transmitter sensors, operating sensitivity of the system, operating modes and calibration can be made on the control card.

3.3. Language Select for Control Card (TC)

When the control card is first powered on, the text KONTAL ELEKTRONIK will appear on the screen.

DIL SECINIZ
SELECT LANGUAGE

Then the buzzer will beep 2 times and text will appear on the screen. After that

1. TURKCE
>2. ENGLISH

language selection will appear on the screen. You can select a language for your control card on the menu. After choosing the language, the text "TOSBA V2.2" will appear on the screen.

In order to perform operations on the control card, first enter the menus. You need to press and hold the Enter/Esc button to enter and return to the menu on the device, but while navigating through the menu, it will be sufficient to press and release the same button (Enter/Esc) to enter the relevant setting.

The processing time in each option is 15 seconds. If no button is pressed within 15 seconds while navigating the options, the system will automatically return to the main page.

4. CONFIGURATIONS

4.1. MAGNETIC FIELD MODE



Before registering the transmitter sensor to the receiver, you need to enter **MAGNET. FIELD** and see the suitability of the places where you will use your products. It is recommended to operate the system within the optimal range of 20 to 60 uT. The system will not function if the magnetic field exceeds 300 uT. The position of the sensor must not be changed during and after registration process. It should never be moved.

This is the menu used to find out the suitability of the area where the product will be installed. When you reach the **Magnetic Field Mode** on the receiver, activate the mode by pressing the **ENTER/ESC** button. If the sensor card has not been taught to any receiver before, press button on the sensor card for 2 seconds. The system will enter the installation mode and send the magnetic value of that environment. You can see the magnetic field value in uT on the screen. If the sensor is taught to a receiver, when we bring a metal object closer to the sensor and pull it, the sensor will enter this mode and send the magnetic field value the environment it is in.

4.2. SENSOR REGISTER



This menu is used to teach a sensor (TS) to the control card (TC). Firstly, a way is selected and maximum of 2 transmitter sensors can be registered on this way. A total of 8 sensors can be taught in 4 different ways. To activate the learning mode of the control card, first a way is selected, for example **WAY1**, then the sensor is selected (**SENSOR1/OPEN**) and when the control card enters the learning mode; the buzzer on the card will beep for 15 seconds and "**SENSOR DATA WAIT**" will appear on the screen. During this period, if you want to save the sensor as **SENSOR1** to the receiver for the first time, press and release the button on the TS card once. If you have previously taught the sensor to a receiver, this time you need to approach a metal object to the sensor and pull the metal object over it. The sensor will send learning data and when the control card learns this sensor, the buzzer will beep 3-4 times quickly (on/off). This will complete the registration process. You can then continue the process by registering as many sensors as you need. For example, user who wants to use the system in serial mode (Figure 2) by using a second transmitter sensor to be placed on the same way must select **WAY1** again and this time register in the **SENSOR2/CLOSE** section. Thus, the user will be able to use the product in serial mode. However, in the same learning system, user who wants to operate one transmitter sensor at the entrance and the other at the exit (Figure 1) will select **WAY2** after **WAY1** and select **SENSOR3/OPEN** and complete the same teaching process here as well. In this way, a single control card (TC) will be able to control both entrance and exit.

The number of sensors changes with the number of ways. For example, while registration is made to **SENSOR1** and **SENSOR2** for **WAY1**, **SENSOR3** and **SENSOR4** are used for **WAY2**.

If there is a sensor registered on the way and sensor number you want to register, you will see the **SENSOR REGISTER MEMORY FULL** warning on the screen.

If there are 8(maximum) sensors registered in your receiver's memory, you will see



the warning on the screen.

4.3. SENSOR DELETE



In order to delete the sensor from the control card memory, you can enter the SENSOR DELETE tab from the menu and perform the deletion. In this tab, you must select the way on which you want to delete the sensor or sensors. When the road selection process is completed, you will see a warning



on screen. When you select the option, the sensors registered on the way will be deleted.

If a sensor is not registered in the receiver, you will see a warning message



on the screen.



After the deletion process, if the sensor is active, the text "TOSBA" will appear on the receiver screen, and the sensor will become passive as a result of a metal object being brought close to the sensor. As a result of this process, both the receiver and the sensor will be completely erased from memory.

4.4. SENSOR INFORMATION



If one of the defined sensors is triggered after entering this option, **the working mode of the sensor (serial or parallel), the remaining battery level and sensor sensitivity level** are displayed on the screen.

4.5. CALIBRATION



During the system operation, many different magnetic field changes may occur for various reasons. This may cause the system to trigger itself or even remain constantly open. The sensor that has already detected will not react to changes in the magnetic field. The control card has a SENSOR CALIBRATION mode specifically for security purposes in such situations. When this mode is selected on the screen, when one of the desired registered sensors sends data, the calibration settings of that sensor will be made. In this way, if there is a sensor that is triggered, it will re-adjust itself according to the magnetic field of its location and the system will continue to operate. This process can take up to 5 minutes.

4.6. SENSIBILITY



It is the part where the detection sensitivity of the wireless vehicle detector system is made. The operating sensitivity of the system is between 3 levels. **These levels are: low, medium and high.** The operating sensitivity of the transmitter sensor is adjusted with the help of the **UP** and **DOWN** buttons on the control card. When you reach the sensitivity level you want, you can save the settings with the **Enter/Esc** button. As soon as you do this, the word **SENSOR DATA WAIT** will appear on the screen. When you show a metal object to the sensor, the sensor will perform the sensitivity adjustment process and the text **SENSITIVITY SUCCESSFUL** will appear on the screen.

4.7. RELAY OUT TIME



TOSBA detects the vehicle approaches and sends this information to the control card. With the received data, one of 4 outputs on the card is triggered. How long these trigger times will be is determined by the relay output settings. This heading is divided into two as pulse and toggle modes. If you want the relay outputs on your control card to be active for a while and then become passive again, you can enter the pulse mode and choose the time your relay will remain active. Pulse mode relay trigger times are **1sec, 2sec, 3sec, 5sec, 8sec** and **10sec**. In the toggle mode, the relay will output as long as the vehicle remains on the transmitter sensor. However, when the vehicle leaves from the transmitter sensor, the relay will become passive. The time after which the relay will become inactive can be adjusted via the control card. These durations are **1sec** (close immediately after the vehicle leaves), **2sec, 3sec, 5sec, 8sec** and **10sec**.

4.8. COUNTER



This option displays the number of vehicles passing over the roads to which the transmitter sensors are connected. When you enter the **COUNTER** section under the status information option, way select appear. By pressing the **UP** and **DOWN** buttons, you can see how many vehicles have passed by on the way. If you want to reset counter on this way, press **UP** and **DOWN** buttons together for 2 seconds. When the reset process is completed, you will see **COUNTER RESET SUCCESSFUL** on the screen.

5. OPERATING MODES

Feature	Descriptions
Parallel Mode	In this mode, the four channels work independently of each other. The settings made on the control card are the same for all four channels.
Serial Mode	Serial mode is used when two transmitter sensors (TS) are placed one after the other on the same road. When the sensor in front of the barrier detects, the trigger is given, and when the second sensor detects the leaving vehicle behind the barrier, the trigger drops.

5.1. RELAY MODES

Feature	Descriptions
Pulse Mode	In this mode, when the vehicle is detected, the trigger is given for the time specified in the control card (Relay out → Pulse).
Toggle Mode	In this mode, the trigger is given as long as the vehicle is on the transmitter sensor. The trigger is cut off when the vehicle leaves the sensor. If you want the control card to remain on the trigger for a while after the vehicle leaves, you must enter the RELAY OUT option and select the time by entering the TOGGLE MODE section.

5.2. Series Mode Selection

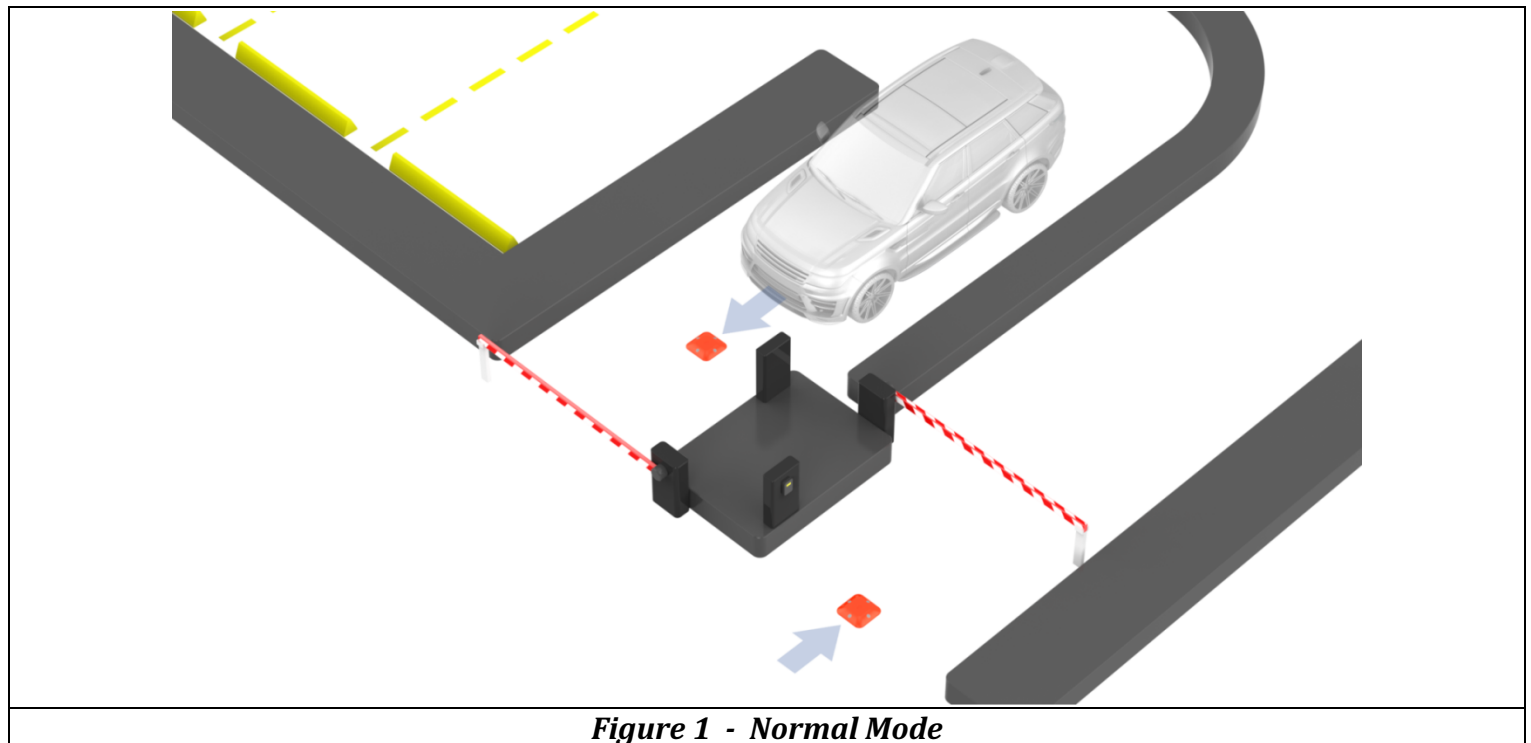

Figure 1 - Normal Mode

In normal mode, there is only one sensor in the same road, while in serial mode there are two sensors on the road. **Figure 1** shows the normal mode, and **Figure 2** shows the sensor placement in serial mode.

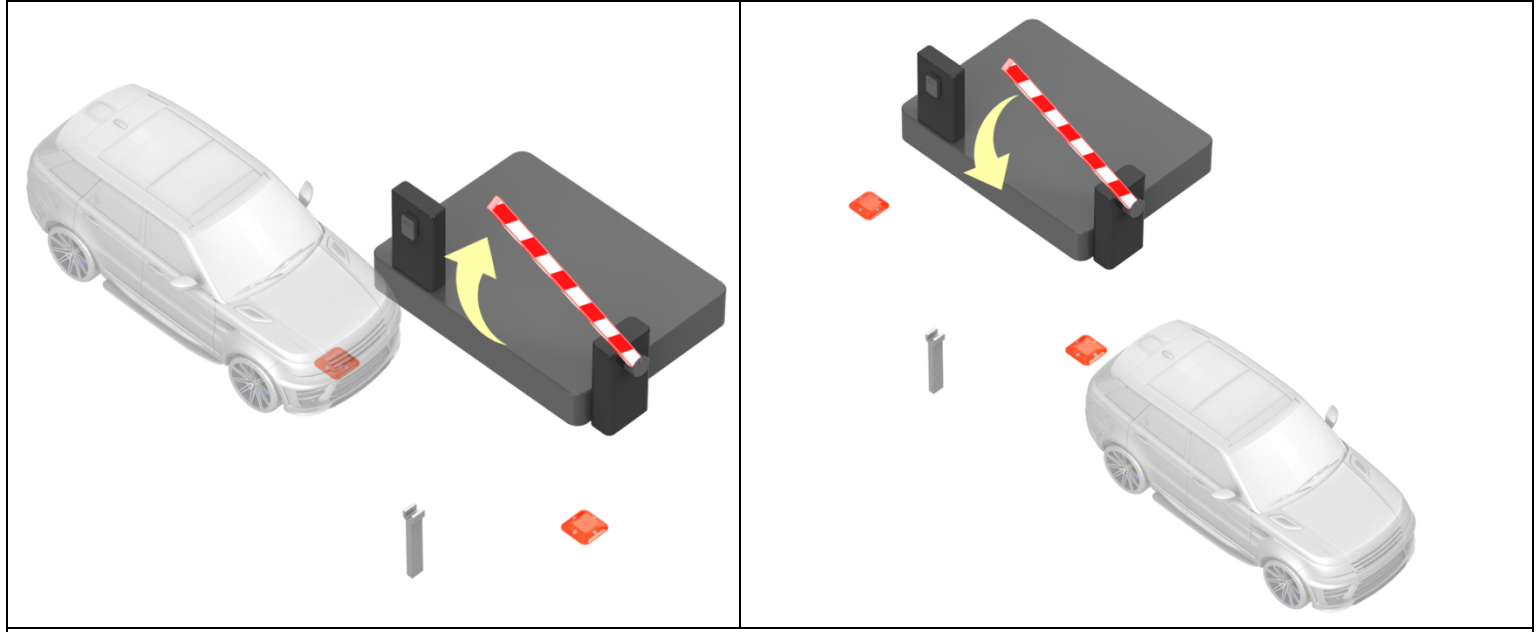

Figure 2 - Serial Mode

Serial mode is the mode used with two transmitter sensors (TS) laid on the same road. In this mode, transmitter sensors are placed on both sides of the barrier. In this way, it is possible to control the approach and departure of the vehicle to the barrier. It is required that the vehicle passes through both transmitter sensors. Vehicles coming in the wrong direction can be detected and the trigger is not given. For example, when the vehicle moving from left to right is detected by the first sensor, the barrier opens and is kept open. The barrier is lowered after the vehicle continues to move forward and leaves the second sensor.

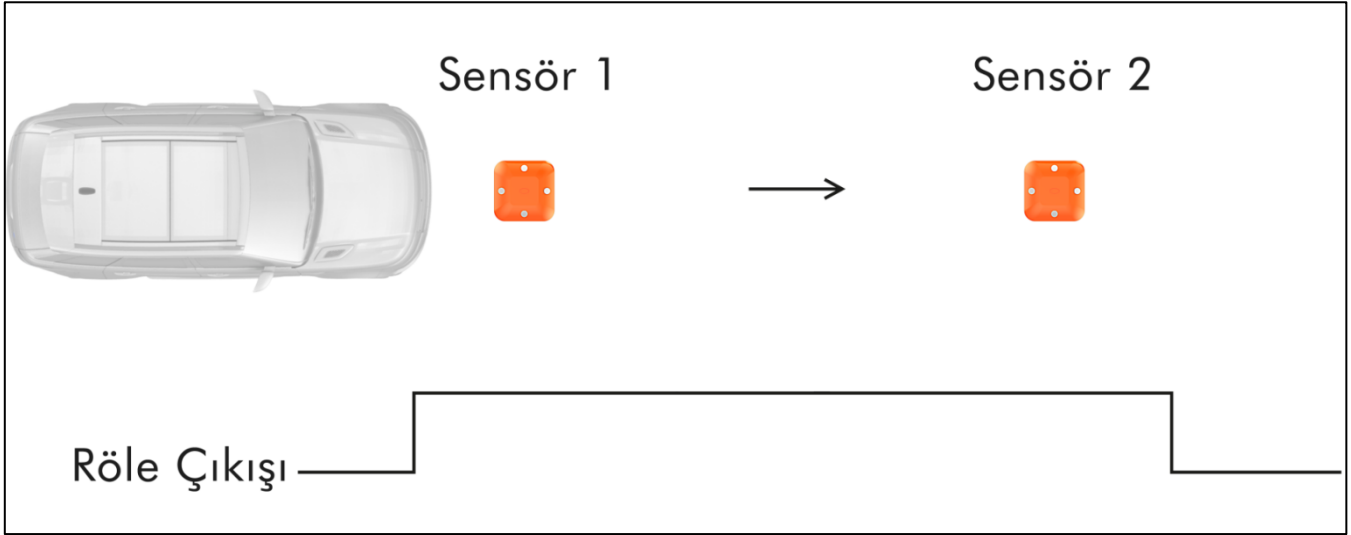

Figure 3 - Serial

The above image shows the relay outputs of the system operating in serial mode. While the vehicle is moving from left to right, the relay output is triggered as soon as it comes on **sensor1**, the relay output stays on until the vehicle leaves by passing over **sensor2**. When the vehicle leaves via **sensor2**, the relay output is deactivated.

6. USAGE AREAS

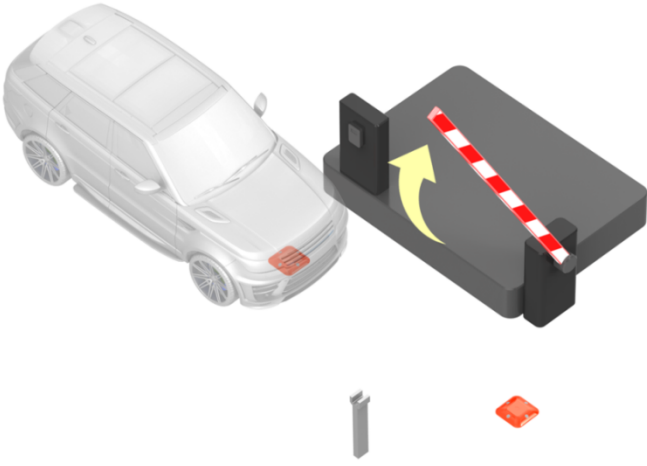

Figure 4 – Use in Arm Barrier

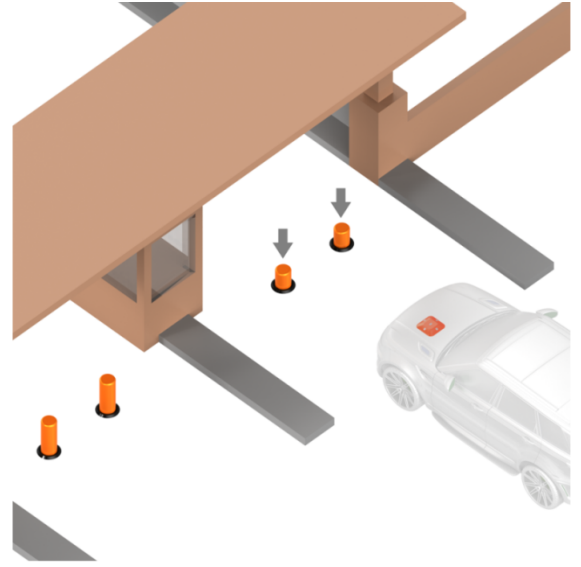

Figure 5 – Use in Bollard Barrier

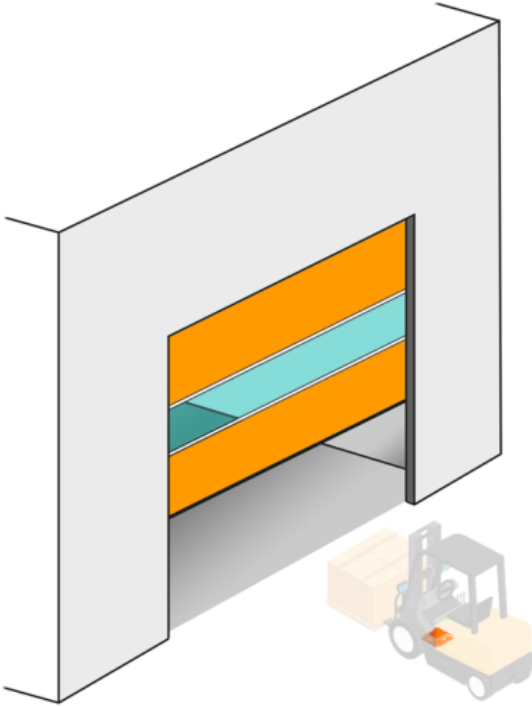

Figure 6 – Use in Shutters

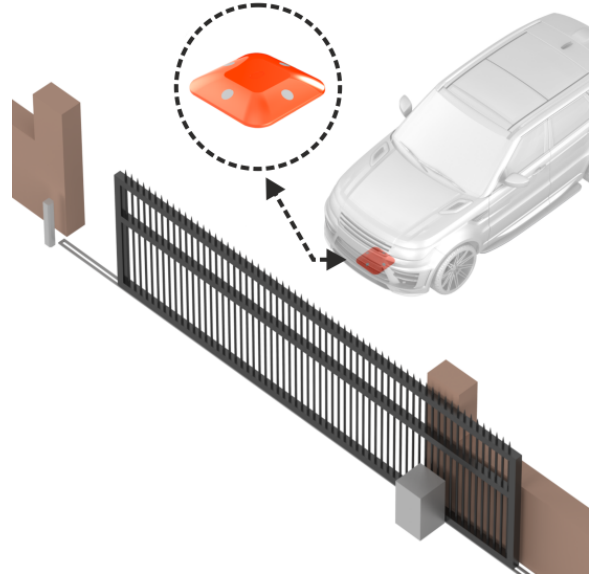

Figure 7 – Use in sliding door

Wireless vehicle detector is a product that can be used where there is a vehicle entrance and exit. It is frequently used in the market for barriers, swing doors and shutters. Doors in these three areas can be easily controlled by using one of our company products, **GAF(K008-01)**.

7. RECEIVER CONNECTION DIAGRAM

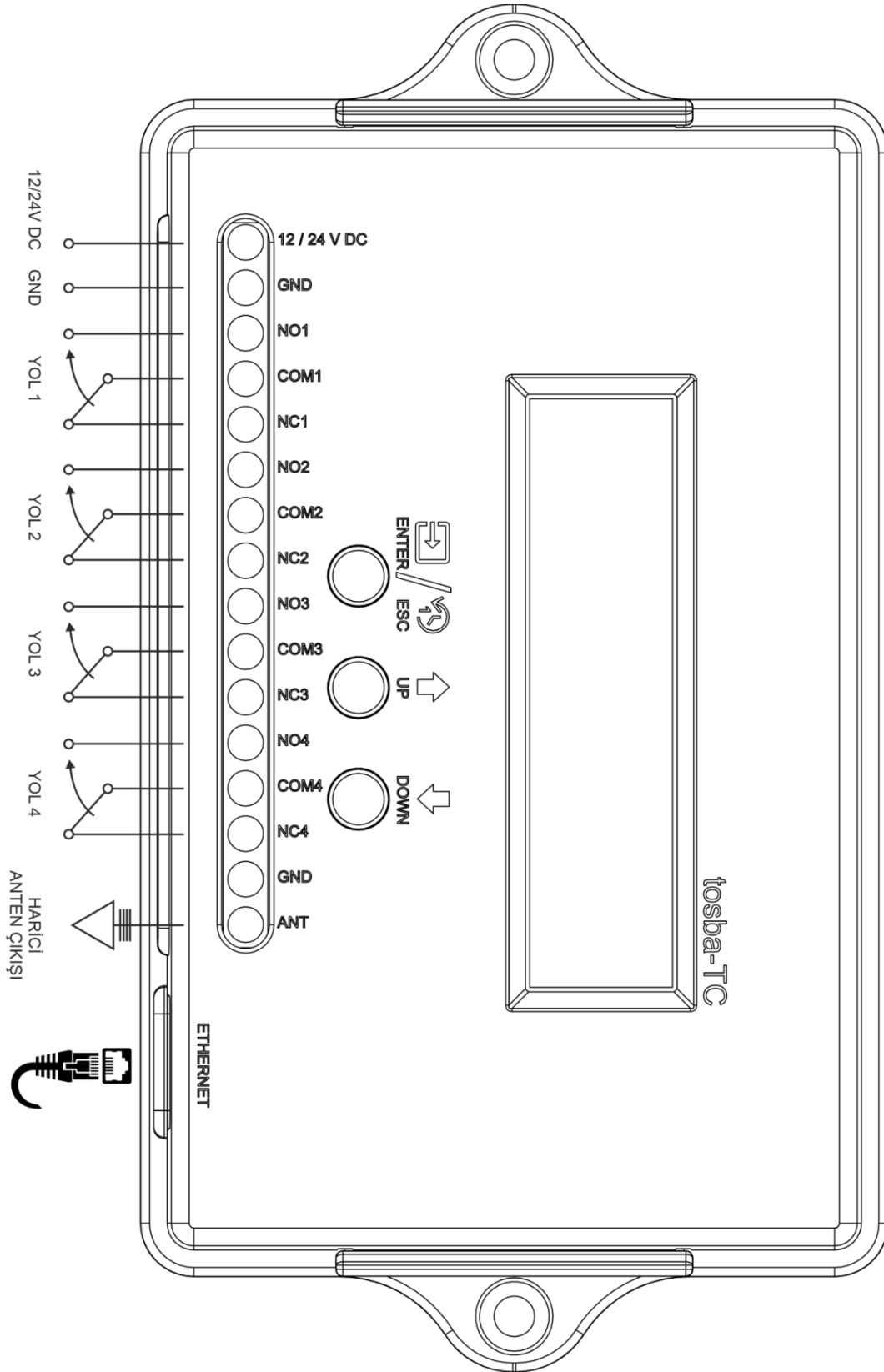

Figure 8 - TC Connection Diagram



Take care that the installation of your TC card is not over 2 meters.

8. INSTALLATION



Before registering a transmitter sensor to your control card, mount your products (transmitting sensor) to the places where you will use them. The position of the transmitter should not change during and after registration. It must not be moved.

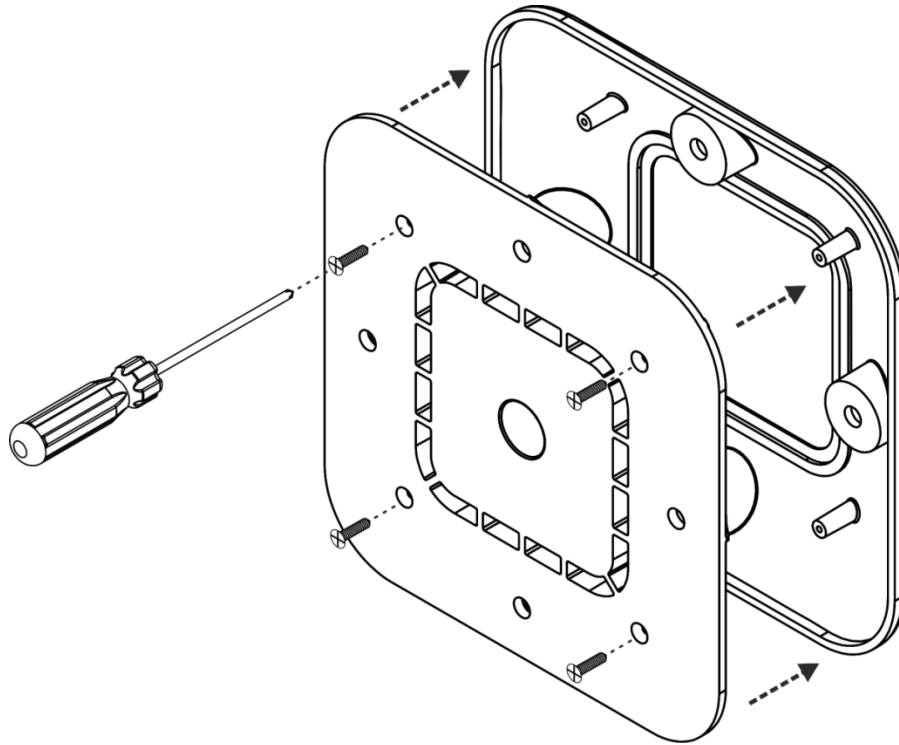

Figure 9 - Opening the top plastic with the help of a screwdriver

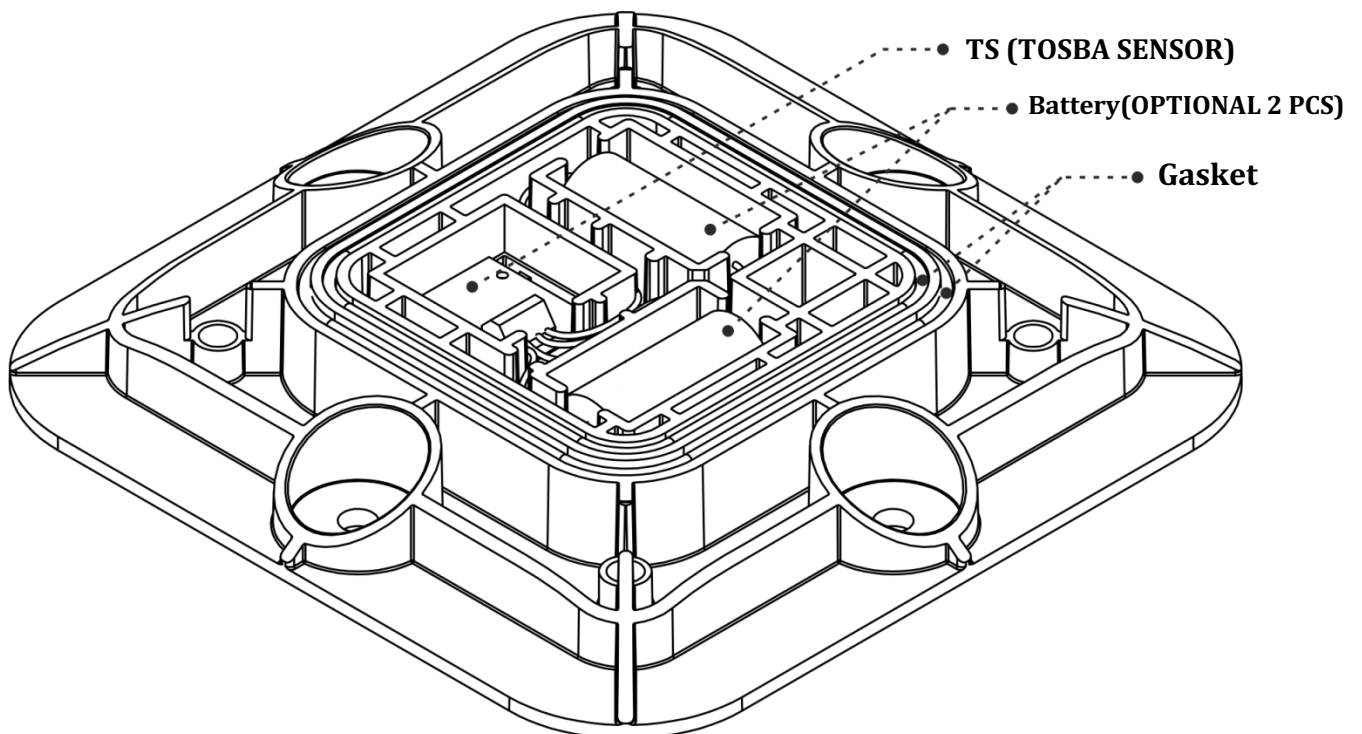

Figure 10 - TS board internal structure



Make sure your TS card has its gasket installed to prevent water leakage.

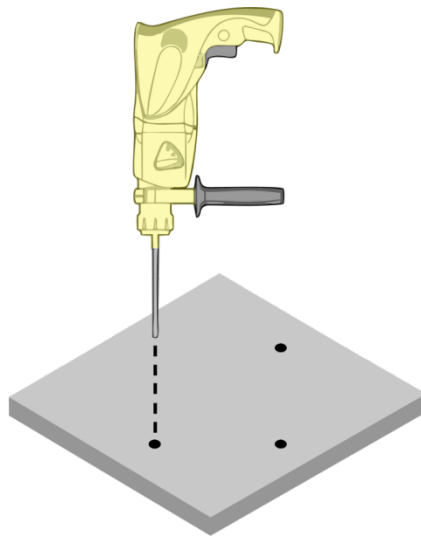

Figure 11 - With a drill, 10 mm diameter 105 mm long metric screws and 16 mm diameter dowels will be drilled into the asphalt floor.

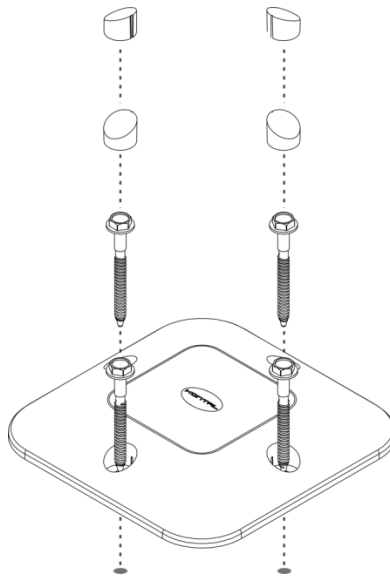

Figure 12 - The assembly will be completed by attaching screws and protective plastics.

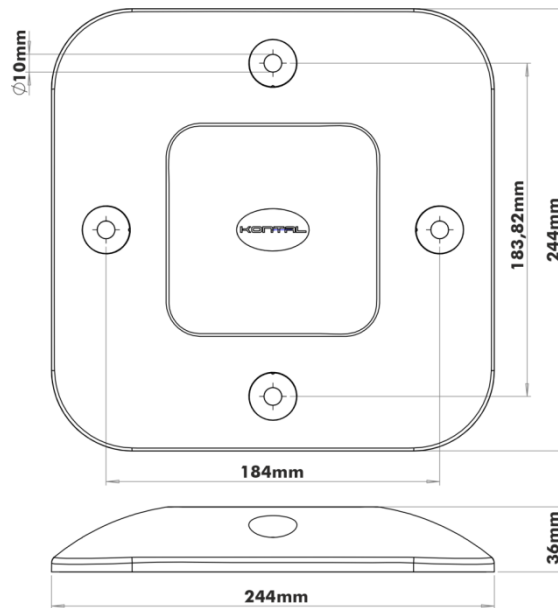

Figure 13 - Dimensions (mm)

➤ Receiver Installation Stage

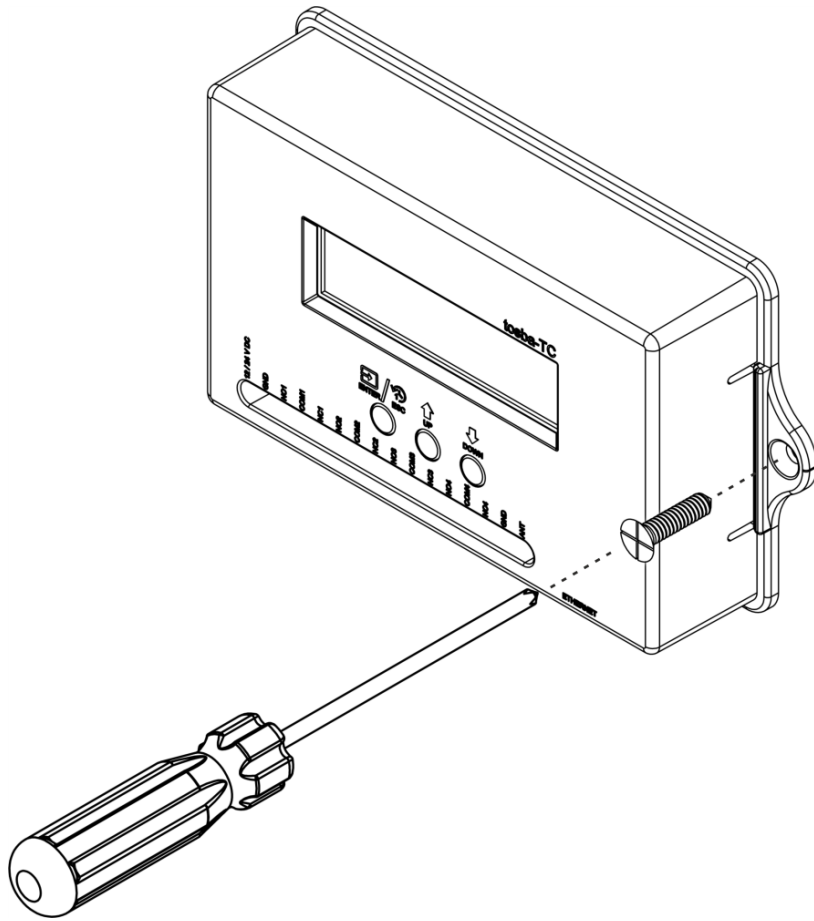

Figure 14 - Fix it to the Appropriate place with the help of a screwdriver.

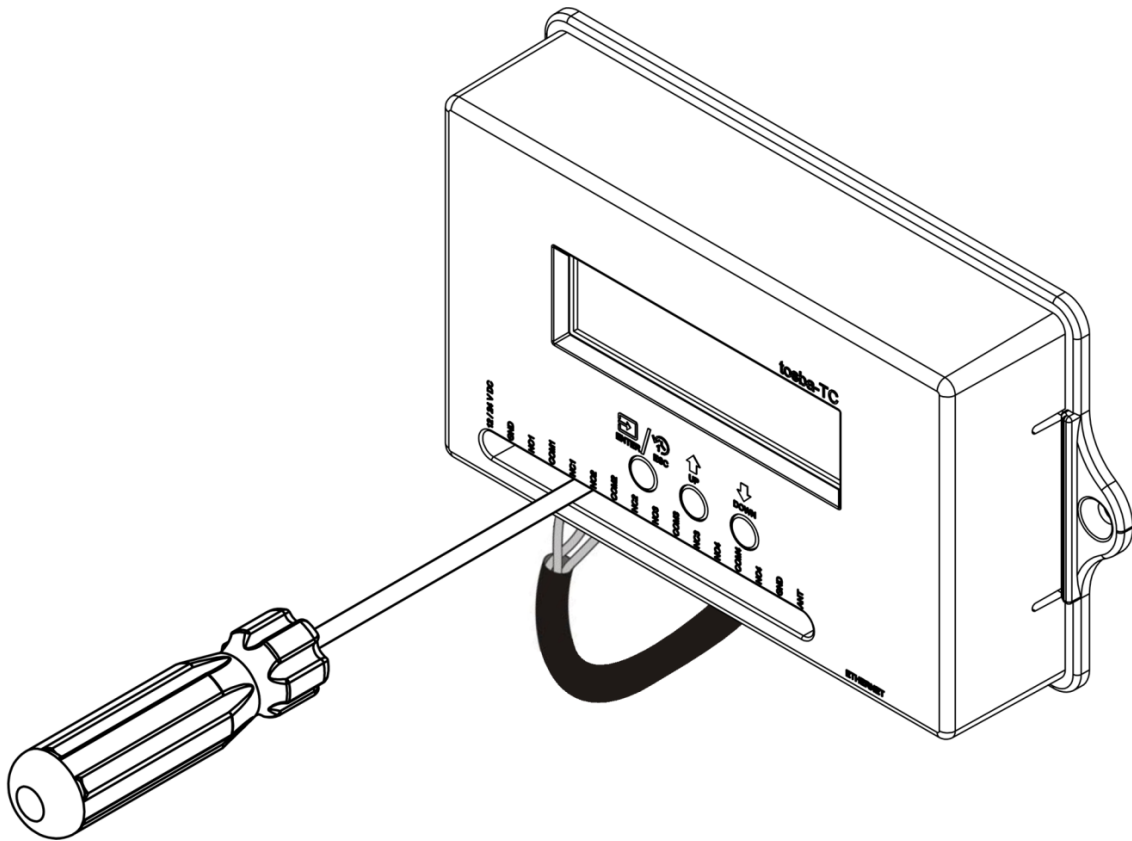

Figure15 - Make your terminal connections.

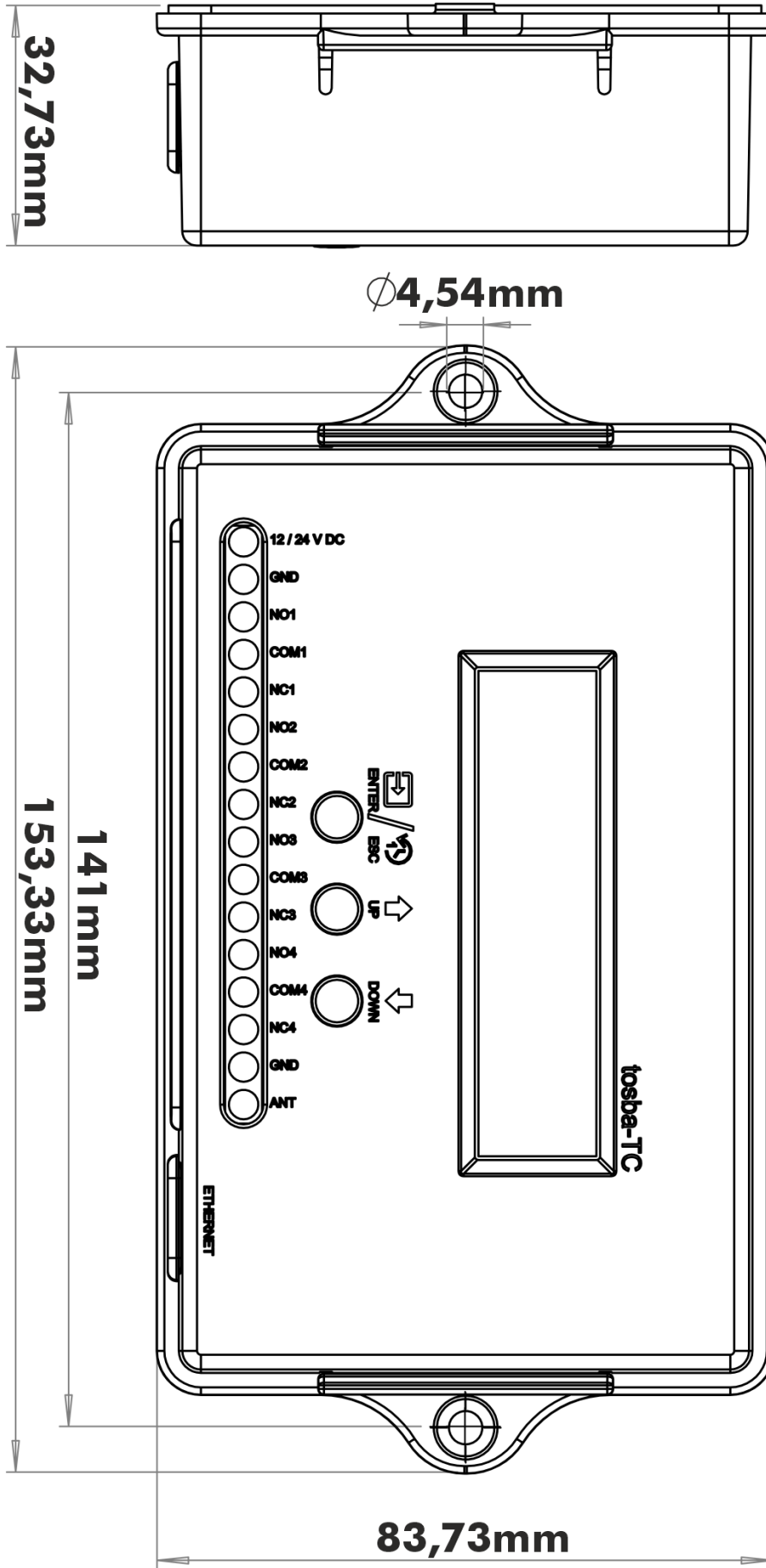

Figure 16 - Dimensions (mm)