

FEIG

CONTROLLER

Intelligent Door Management

Assembly instructions

Installation, commissioning, utilization and maintenance

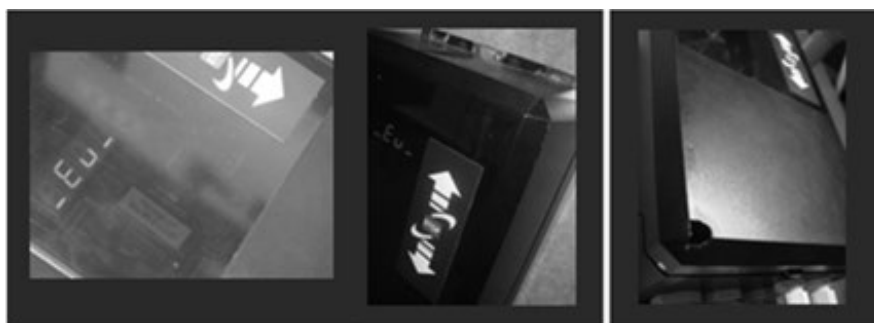

TST WUE2

- EN ATTENTION IMPORTANT SAFETY INFORMATION!
Follow the instructions on page 3 of this manual.
- GB ATTENTION! IMPORTANT SAFETY INFORMATION!
Follow the instructions on page 3 of this manual.
- FR ATTENTION! IMPORTANTES INDICATIONS DE SÉCURITÉ!
Les instructions de la page 3 de cette notice de montage doivent être observées strictement,
- NL LET OP! BELANGRIJKE VEILIGHEIDSLINSTRUCTIES!
Volg de instructies op pagina 3 van deze montagehandleiding op.
- IT ATTENZIONE! INDICAZIONI SULLA SICUREZZA IMPORTANTI!
Prestare attenzione alle note alla pagina 3 delle presenti istruzioni di montaggio.
- ES ATENCION INDICACIONES IMPORTANTES DE SEGURIDAD!
Deben seguirse las indicaciones detalladas en página 3 de estas instrucciones de montaje.

ATTENTION

IMPORTANT SAFETY INFORMATION!

These instructions must be observed to ensure personal safety.

Store these instructions safely.

Note

© Copyright 2018 by
FEIG ELECTRONIC GmbH
Industriestrasse 1A
D-35781 Weilburg
Tel.: +49 6471 3109 0
www.feig.de

Version: 2023-03-30

This edition replaces all earlier versions.
The specifications in this document are subject to change without notice.

The transmission and reproduction of this document, and utilization and disclosure of its contents are not permitted unless expressly authorized. Violations will result in liability for damages. All rights, including rights created by patent grant or registration of a utility model or design, are reserved.

This Manual is directed especially at persons involved with commissioning the **TST WUE2** door controller of FEIG ELECTRONIC GmbH. The installation and commissioning of the controller shall only be carried out by officially trained electrical experts who are familiar with the safety standards of electrical drive and automation technology.

The distributor of the machine is solely responsible for the completeness of the operating instructions for the machine (in this case the door). The installation instructions for the door controller that is installed by the manufacturer of the door shall be supplied in one of the languages of the European Community that is accepted by the manufacturer of the machine.

This Manual shows only a small range of the controller's functions and provides no warranty of properties. Additional functions and descriptions for individual door functions as well as more precise specifications for the controller and hazard warnings are available in the main description.

The compilation of the information in this document has been done to the best of our knowledge and with due diligence. FEIG ELECTRONIC GmbH does not warrant the correctness and completeness of the information in this document. In particular, FEIG ELECTRONIC GmbH cannot be held liable for consequential damages due to incorrect or incomplete information.

In spite of the best efforts, mistakes cannot be avoided completely and we will always gratefully accept any information in this respect.

The installation recommendations contained in this document presume favorable general conditions. FEIG ELECTRONIC GmbH assumes no liability for the proper operation of the equipment in third-party environments. FEIG ELECTRONIC GmbH provides no warranty that the information in this document is not subject to foreign copyrights. By furnishing this document, FEIG ELECTRONIC GmbH does not grant any licenses to its own or foreign patents or any other intellectual property rights.

Only the direct contracting parties shall be entitled to warranty claims against FEIG ELECTRONIC GmbH; warranty claims are non-transferable. The warranty covers only products supplied by FEIG ELECTRONIC GmbH. There are no express warranties except as listed above.

The description of the products, their utilization, capabilities and performance specifications shall not be considered as warranted properties and are subject to technical change.

General information about this document

Language of the **original operating instructions**: German

The functional description employs the following characters to indicate the different danger areas and useful tips.



indicates a risk to persons if the procedure is not carried out as described.



indicates that the controller is at risk.



points out information which is IMPORTANT to the operation of the door controller and/or the door.



points out information which is useful but not essential for the use of the door controller TST WUE2.

EN ATTENTION IMPORTANT SAFETY INFORMATION!

These instructions must be observed to ensure personal safety. Store these instructions safely. These installation instructions are available from the download area at www.feig.de. Please sign in with the following details: Username: Download / Password: feig

GB ATTENTION! IMPORTANT SAFETY INFORMATION!

These instructions must be observed to ensure personal safety. Store these instructions safely. These installation instructions are available from the download area at www.feig.de. Please sign in with the following details: Username: Download / Password: feig

FR ATTENTION! IMPORTANTES INDICATIONS DE SÉCURITÉ!

Pour la sécurité des personnes, il est important de respecter les consignes en question. Les présentes consignes doivent être conservées en lieu sûr. Les instructions de montage sont téléchargeables dans la zone téléchargements de www.feig.de. Prière de vous logger avec les données suivantes: Nom d'utilisateur : Download / Mot de passe: feig

IT ATTENZIONE! INDICAZIONI SULLA SICUREZZA IMPORTANTI!

Per la sicurezza personale è importante attenersi scrupolosamente a queste indicazioni. Queste indicazioni vanno conservate. Le presenti istruzioni di montaggio sono disponibili nell'area download del sito www.feig.de. Effettuare il login con i seguenti dati d'accesso: Nome utente: Download / Password: feig

ES ATENCIÓN INDICACIONES IMPORTANTES DE SEGURIDAD

Para la seguridad de las personas es importante seguir estas indicaciones. Deben guardarse estas indicaciones. Puede encontrar estas instrucciones de montaje en el área de descarga en www.feig.de. Se ruega iniciar sesión con los siguientes datos de acceso: Nombre de usuario: Download / Password: feig

NL OP! BELANGRIJKE VEILIGHEIDSINSTRUCTIES!

Voor de veiligheid van personen is het belangrijk om deze aanwijzingen op te volgen. aanwijzingen dienen bewaard te worden. Deze montagehandleiding kunt u vinden als download op www.feig.de. Gelieve de volgende toegangsgegevens te gebruiken: gebruikersnaam: Download / wachtwoord: feig

The screenshot shows the FEIG ELECTRONIC website's login page. At the top left is the FEIG ELECTRONIC logo. The top navigation bar includes 'PRODUKTE', 'BRANCHEN', 'EVENTS', 'SERVIC', 'NEWS', 'KARRIERE', 'UNTERNEHMEN', 'KONTAKT', and 'SUCHEN'. A search bar labeled 'PRODUKTFINDER' and social media icons are also present. A 'jetzt registrieren für unseren Newsletter' button is in the top right. The 'HOME_LOGIN' link is visible on the left. A dropdown menu under 'SERVIC' is open, showing 'KUNDENCENT', 'EU-KONFORMITÄTSERKLÄRUNG', and 'RETOUREN', with a callout box '1' pointing to it. The login form on the right has 'Benutzername:' with 'Download' and 'Passwort:' with 'feig' entered, and a callout box '2' pointing to the password field. Below the form is an 'ANMELDEN' button with a callout box '3' pointing to it. On the left of the form, there is a 'BENUTZERANMELDUNG' section with instructions and links for registration and password recovery.

Content

Note 2

General information about this document	2
1 General description and intended use	7
1.1 Intended use	7
1.2 Incorrect use.....	8
1.3 Target group	8
1.3.1 Personnel qualification.....	8
1.4 Duty of care of the operating company	10
2 Safety information	11
3 Safety functions in accordance with EN 12453:2017	12
3.1 Connection example testing	12
3.2 Parametrization	12
4 Installation of the controller	13
5 Electrical connection	14
6 Product overview	15
6.1 Housing variants	15
6.1.1 Housing variant 1 / small housing	15
6.1.2 Housing variant 2 / large housing	17
6.1.3 Variants in steel or stainless steel housings	18
6.1.4 Hygiene Zone variant.....	21
6.1.5 Mount the board variant in a steel housing	22
6.2 Overview of the TST WUE2	25
6.2.1 Terminal description.....	27
6.3 Power supply connection.....	29
6.4 Motor and brake connections	30
6.5 Connection of safety edge	31
6.5.1 Connection of an electrical safety edge	32
6.5.2 Connection of an optical safety edge.....	33
6.6 Safety edge at the 2nd integrated evaluation (input 10)	34
6.6.1 Connection of an optical safety edge.....	34
6.6.2 Connection of an electrical resistance safety edge	35
6.6.3 Connection of a digital input.....	36
6.6.4 Connection of a slack rope switch/door switch	37
6.7 Light curtain TST LGB	38

Door controller	Assembly instructions	WUE2
6.7.1	Installation of the TST LGB.....	38
6.7.2	Connection of the TST LGB.....	39
6.8	Wiring diagram of the Wiring board TST RLGxA.....	42
6.9	Limit switch connection	44
6.9.1	Absolute encoder TST PE FSP with WICAB system	45
6.9.2	Absolute encoder TST PD	46
6.9.3	Absolute encoder DES.....	47
6.9.4	Mechanical limit switches.....	48
6.10	Light beam	49
6.10.1	External triggering devices.....	50
6.10.2	Traffic light connection	51
7	General operating instructions to set parameters	52
7.1	Open the parameter operation mode	52
7.2	Editing a selected parameter	53
7.3	Exit parameter operation mode	53
7.4	Execute a reset.....	53
7.5	Entry into the extended parameter configuration mode.....	54
8	Basic settings	55
8.1	Automatic query of basic data.....	55
9	Startup... ..	55
9.1	... with absolute encoder.....	56
9.1.1	Renewed request for "learning" limit positions	57
9.2	... with mechanical limit switches	57
9.3	... with light curtain TST LGB	58
10	Functions	59
11	Error messages	60
12	Information messages	71
13	General messages	72
14	Specifications	74

1 General description and intended use

The device described below is an electronic control system for motor-driven industrial or commercial doors in accordance with *EN 13241*. The **control system TST WUE2** is designed to handle electrical induction motors with a power consumption of up to 4 kW and a 400 V supply

In addition to controlling the motor that drives the door, the controller can be used for the following tasks:

- Positioning the door at and between its final positions (open, close and intermediate positions)
- Evaluation of the security sensors on the door (e.g. safety edge monitoring, pull-in protection, etc.)
- Evaluation of additional safety equipment on the door (e.g. photo eyes, light curtains, etc.)
- Evaluation of control circuits at the door (e.g. pull switch, radio, inductive loops, etc.)
- Evaluation of emergency stop controls
- Electronically protected 24V low-voltage power supply for sensors and control devices
- 230 V power supply to external units
- Control of application-specific outputs (such as relays for door position reporting)
- Generation and output of diagnostic messages
- Configuration of application-specific parameters for different levels of access of the different user groups.
- Control of input/output expansion

NOTE

When using the TST WUE3 software version, it is not possible to use the TST SUKS-A safety edge evaluation board at input 31.

- TST SFFE lug-in module wireless remote control
- TST FSx wireless Security System
- TST SUVEK plug-in module for inductive loop detection
- TST RWU Input / output expansions incl. ports for lockage applications, etc.
- TST LCD/clear text clear text display with 2 x 16 characters
- TST SUKS-A safety edge evaluation board
- TST LGB light curtain
- TST RLGxA wiring board

1.1 Intended use

- The controller TST WUE2 is designed for the operation of an electrical induction motor with a power consumption of up to 4 kW at 400 V supply any may only be used for the operation of motor-driven doors and gates used in an industrial or commercial context as defined by the door product standard DIN EN 13241.
- Intended use includes compliance with all the specifications made in this assembly manual pertaining to assembly, installation and commissioning, the applicable safety instructions and consideration of the technical data.
- The controller may only be operated with accessories authorized by FEIG ELECTRONIC GmbH.
- All assembly, installation, commissioning and maintenance work performed on doors or gates or on the drive units intended for the doors or gates are to be performed exclusively by qualified specialist personnel as defined by the EC Machinery Directive. In particular, the following regulations require compliance: VDE 0100, EN 50110, EN 60204, EN 60335 inc. part 103, the fire protection regulations, accident prevention regulations and the applicable regulations for industrial doors (EN12453, EN12978) and machine safety (EN ISO 13849, EN 62061).

1.2 Incorrect use

Incorrect use includes all use of the controller which is classed as non-intended use. .

This device is not intended for use by persons (including children) with limited physical, sensory or mental abilities or lacking in experience and / or knowledge, unless they are supervised by a person responsible for their safety or if they have received instructions regarding the use of the device. Children should be supervised to ensure that they do not play with the device. Keep remote controls away from such persons.

Should the controller be subject to any use other than that described, the operating company will be liable for the resulting damage. This applies to unauthorised alterations, modifications or programming to the controller and its components as well as ignoring of warnings and safety instructions.

The following points in particular are classified as incorrect:

- Use outside the specified assembly conditions and safety distances to the surroundings (place and temperature).
- Use in an explosive or easily flammable environment.
- Use with defective parts.
- Use with spare parts and extension boards, which have not been approved by FEIG ELECTRONIC GmbH.
- Use without safety devices.

1.3 Target group

This assembly manual is directed especially at persons involved with commissioning the controller of FEIG ELECTRONIC GmbH.

The assembly and commissioning of the controller may only be carried out by officially qualified electricians familiar with the safety standards of electrical drive and automation technology.

1.3.1 Personnel qualification

The FEIG ELECTRONIC GmbH controller may only be operated and maintained by persons who comply with the requirements outlined here and are familiar with the safety standards of electrical drive and automation technology.

All the person groups specified here must have read and understood this assembly manual before using the controller.

Persons under the influence of drugs or alcohol or who have taken medicines which restrict their reactive ability are not permitted to perform work on the controller.

The assembly manual differentiates between the following groups:

Person group	Requirement	Authorisation/task
Operating company	The operating company is in possession of the controller and is responsible for ensuring its intended use. It is to ensure that all persons performing tasks on the controller have been given professional training and fulfil the requisite bodily and mental requirements for dealing with the controller.	<ul style="list-style-type: none"> ▪ <i>Deploy authorised personnel</i> ▪ <i>Deploy the product in accordance with its intended use</i> ▪ <i>Training</i>
Operator	The operator was informed of the function of the controller and is able to operate the assembled and installed controller. Operators include all persons who deal with the machine over its various life phases. This can be specialist personnel with or without special training or laypersons.	<ul style="list-style-type: none"> ▪ <i>Operation</i>
Qualified specialist personnel	The qualified specialist personnel has been provided with training pertaining to working with electrical equipment and informed about possible dangers resulting from improper behaviour. The qualified specialist personnel is familiar with the necessary protective measures and devices. They are also in possession of the requisite qualification to perform tests on work equipment resulting from their professional training and recent experience.	<ul style="list-style-type: none"> ▪ <i>Unpacking</i> ▪ <i>Assembly</i> ▪ <i>Installation</i> ▪ <i>Commissioning</i> ▪ <i>Repair</i> ▪ <i>Operation</i> ▪ <i>Programming</i> ▪ <i>Disposal</i> ▪ <i>Checking</i>
Electrician	An electrician is qualified to work in the working environment of electrical systems; their knowledge and experience enable them to perform and monitor electro-technical work without danger. The electrician is familiar with the relevant standards and specifications and knows the specifications of the valid legal regulations pertaining to accident prevention. They take part in regular measures of further training. Electricians currently undergoing training (also minors) are only permitted to perform work under the supervision of an experienced electrician; this requires the express permission of the operating company.	<ul style="list-style-type: none"> ▪ <i>Unpacking</i> ▪ <i>Assembly</i> ▪ <i>Installation</i> ▪ <i>Commissioning</i> ▪ <i>Repair</i> ▪ <i>Operation</i> ▪ <i>Programming</i> ▪ <i>Disposal</i> ▪ <i>Instruction</i>
Manufacturer	The manufacturer is involved in the design and production of a partly completed machine and accepts responsibility for conformity of the machine part with the directive.	<ul style="list-style-type: none"> ▪ <i>Design</i> ▪ <i>Production</i> ▪ <i>Disposal</i>
Distributor	The distributor provides a complete machine to the market in terms of its distribution or use.	<ul style="list-style-type: none"> ▪ <i>Distribution</i>

1.4 Duty of care of the operating company

FEIG ELECTRONIC GmbH maintains a certified quality management system in accordance with DIN EN ISO 9001.

The faultless safety condition of the controller and its function are checked in accordance with valid regulations before it leaves our factory. The operating company is to check this state after transport and before assembly of the controller.

The operating company is responsible for maintaining this state by ensuring that

- The controller is installed in accordance with the assembly, installation and safety regulations outlined here.
- Damage is rectified immediately by qualified specialist personnel.
- The controller is operated in a faultless state.
- The controller is assembled, installed and commissioned by qualified specialist personnel only.

2 Safety information

ATTENTION

Failure to observe the safety advisories can result in physical harm or damage to the controller.

When starting up and operating the controller, the following important safety advisories as well as the installation and wiring notes must be strictly observed:

- In accordance with the EC Machinery Directive only qualified personnel shall install the device on the doors or at the drive units for doors or bring them together. The respective safety requirements for the entire door (machine) must be aligned with the possibilities to meeting these safety requirements on the controller.
- Improper integration of the controller into the door complex – e.g. missing sensors, incorrect parameters, speed set excessively high, etc. – presents the risk that the door is operated without adequate safety precautions.
- To comply with the safety function according to EN 13849, a position encoder certified for PL c must be used.
- If an error occurs, a contactor may be turned on permanently!
- In order to avoid hazards due to a defective or sticking contactor, a mechanical stop must be installed in the end positions for all door types
- If an error occurs, the motor may be live even if it has been turned off!
- Manual operation of the contactors is prohibited. The warranty expires if the protective film is destroyed.
- **The commissioning of this controller is prohibited until it has been properly attached to the door that conforms to the EC Machinery Directive and for which an EC declaration of conformity according to Annex II of the Directive was obtained.**
- The following information describes standard applications that may not necessarily match the actual application. The actual application is provided by the manufacturer of the door as part of the overall documentation or as part of the **operating instructions** of the door.
- **Any installation, startup and maintenance work must only be performed by qualified specialists.** In particular, the following regulations must be observed: VDE0100, EN 50110 (VDE0105), EN 60204 (VDE0113), EN 50178 (VDE0160), EN 60335 (VDE0700), fire protection codes, accident prevention regulations as well as the relevant regulations for industrial doors and machine safety standards (EN ISO 13849, EN 62061)(ZH1/494, EN12453, EN12978)
- This device is not intended for use by persons (including children) with limited physical, sensory or mental abilities or with a lack of experience and / or knowledge, unless they are supervised by a person responsible for their safety or if they have received instructions on the use of the device. Children should be supervised to ensure that they do not play with the device. Keep remote controls away from such persons.
- A device mark (nameplate with name and address of the manufacturer, serial number, model number, supply voltage and temperature range) must be applied by the user.
- The example of the warning label must be attached to the motor near the motor terminal board.

Type label:

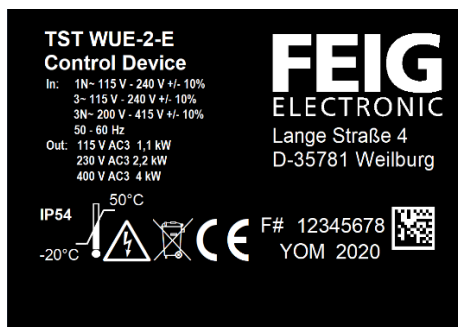

F# [Serial number]

YOM [year of manufacture]

The safety advisories mentioned in this document make no claim to completeness. If you have questions about the product, contact your vendor.

The manufacturer has carefully checked and inspected the hardware and software, but no warranty is given for a complete absence of errors.



Dispose of the product at the end of its life cycle in accordance with the applicable statutory provisions.

Warning notice label (example):



3 Safety functions in accordance with EN 12453:2017

EN 12453:2017 places special requirements on safety-related signals. These signals must comply with a minimum of PL “c”, cat. 2 in accordance with EN 13849-1. To guarantee these safety requirements, the complete chain of sensors, actors and if necessary, the wiring must be taken into account accordingly. This affects (amongst others):

- Path restriction units (limit switch)
- Actuators with automatic reset
- Slack rope switch
- Slip door switch

To comply with these standard requirements, these signals can be connected via the Emergency-Stop inputs of the controller (terminal no. 31-32 and 41-42).

Alternatively, standard digital inputs can be used. In this case, an additional output must be configured as a test output and integrated in the signal chain.

3.1 Connection example testing

In this example, the testing is described using a transmitter-receiver light barrier.

The transmitter is supplied with 24 V via a test output.

In a test case, the output is switched off so that the transmitter is voltage-free.

The receiver now switches the input.

The controller checks whether the input really switches and switches back.

If YES, the test was successful, if NO, error F.928 is set.

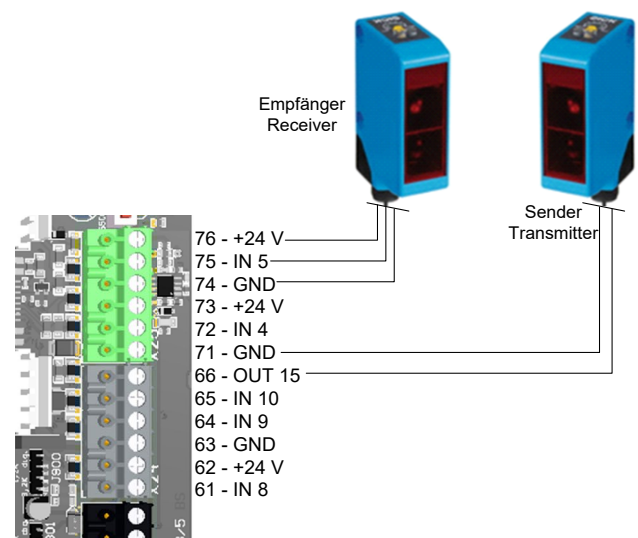

Both digital outputs and relays can use used as a test output.

3.2 Parametrization

To activate the function testing, inputs and a relay must be configured for testing.

1. Input configuration P.5xA:

P.5xA = 0: No testing activated

P.5xA = 1: Testing the input upon reaching the end position OPEN and after activation

P.5xA = 2: Testing the input upon reaching the end position CLOSE and after activation

X = Number of the input to be configured

2. Configuring the output P.7x0:

P.7x0 = 17: Testing in end position CLOSE

P.7x0 = 25: Testing in end position OPEN

The relay is energized when the test is inactive

X = Number of the input to be configured

4 Installation of the controller

⚠️ ACHTUNG

IMPORTANT INSTRUCTIONS FOR SAFE INSTALLATION.

Observe all instructions; incorrect installation can result in serious injuries.

- When installing the controller, the system must be turned off.
- The controller may be opened only if all the poles of the supply voltage have been turned off. It is not permitted to turn on or to operate the controller when it is open.
- Disconnect all supply circuits before opening the housing for access to the terminals.
- Before the installation, check the controller for transport or other damages. Under some conditions a damaged controller may result in significant consequential damage to the controller as well as hazards to the user.
- The controller must never be operated with a damaged membrane keypad or Display window. Damaged keypads and Display windows must be replaced.

⚠️ WARNING

- Do not touch any electronic parts, in particular the components of the processor circuit. Electronic components can be damaged or destroyed by electrostatic discharge.
- Before opening the cover of the enclosure, ensure that no drilling swarf can fall into the housing from the cover.
- When installing the controller it is important to ensure that it is not subject to mechanical stresses.
- Unused cable entries must be sealed to maintain the requirements of IP54.
- Ensure that the cable entries are not subjected to mechanical stresses, in particular tensile stresses.
- The controller must never be operated without the CEE-plug except when the supply voltage can be cut all poles by an installed main switch. The main switch and the CEE-plug must be within easy reach.
- A not rotating motor is no indication of the galvanic isolation from the power grid! The line supply connection terminals, motor terminals and terminals for the brake resistor can still carry dangerous voltages, e.g. under stop or emergency stops.
- If the supply cable is damaged, it must be replaced by the manufacturer or another qualified person in order to avoid danger (like connection type Y EN 60335-1)
- When moving the door in deadman mode, ensure that the operator has an unobstructed view of the door area. In this mode, safety equipment such as safety edge and photo eye may have been defeated. If this is not possible for structural reasons, you must ensure that this mode is only accessible to appropriately trained personnel or that the feature is disabled altogether.
- To prevent damage to the keypad, do not use pointed objects to operate the keys. The keypad is only designed to be operated by human fingers.
- Depending on the type of the door it may be necessary that the door can only be operated when it is within visual range.

In these cases, no remote control (e.g. wireless) may be used to issue commands.

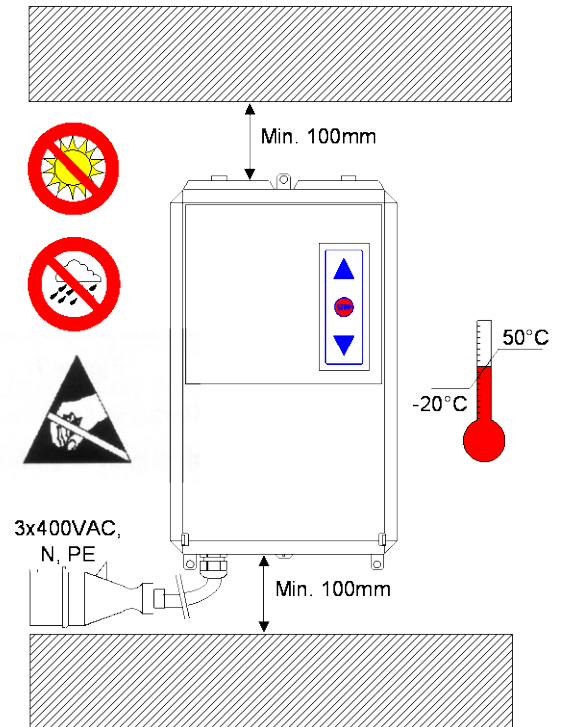

Fig 1: Installation of the controller

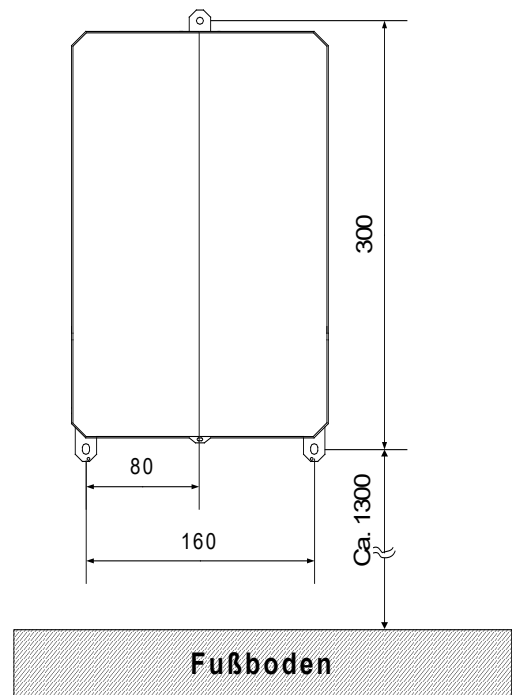

Figure 2: Hole pattern

5 Electrical connection

ACHTUNG

- Any wiring, testing and maintenance work on an open controller shall only be performed when power has been turned off. Pay particular attention to the points shown under "Safety information".
- The controller must never be operated while it is open.
- When the controller has been turned off, dangerous voltage levels are still present for up to 2 minutes.
- Touching electronic components is dangerous due to residual voltages.
- Never operate the controller while the cover is removed.
- When the installation was completed, check that the system was configured correctly and that the safety system works properly.
- The controller may be opened only if all the poles of the supply voltage have been turned off. It is not permitted to turn on or to operate the controller when it is open.
- Never operate the controller without having connected the protective earth conductor. The absence of a protective earth conductor will result in hazardous voltages on the controllers housing caused by terminal capacitances.
- The RFI filters integrated into the controller may increase the leakage current up to a max. of 7 mA (see DIN EN 60335-1 section 16.2). Prior to delivery, the manufacturer will test individual units in this respect.
- Hazardous voltages remain stored in the intermediate circuit capacitors for up to 1/2 minutes after power has been turned off. The discharge time until voltages fall below 60 VDC is a maximum of 1 minutes. Touching internal controller components within this discharge time is hazardous.
- A defective switching power supply can considerably increase the discharge time of the DC-bus capacitors before reaching a voltage less than 60VDC. In this case, discharge times of up to 2 minutes may be possible.
- The processor circuit is galvanically connected to the power line. Important: when taking measurements on the processor circuit, do not use test equipment with PE reference to the measuring circuit.
- The controller must never be operated with a damaged membrane keypad or Display window. Damaged keypads and Display windows must be replaced. To prevent damage to the keypad, do not use pointed objects to operate the keys. The keypad is only designed to be operated by human fingers.
- If the potential free contacts of the output relays or other terminals are supplied by an external voltage, i.e. dangerous voltages that are still present after switching off the controller or disconnecting power, you must attach a suitable warning sign to the housing.

(„ATTENTION! Disconnect all supply circuits before opening the housing for access to the terminals.”)

- When moving the door in deadman mode, ensure that the operator has an unobstructed view of the door area, since in this mode safety equipment such as safety edge and photo eyes are defeated.
- Parameter settings and the function of all safety devices must to be checked. Parameter settings and insertion of jumpers shall only be performed by properly trained persons.

WARNUNG

- Before turning on the controller for the first time and after completion of the wiring, check whether all motor connections are tight on the controller and the motor side and whether the motor is correctly wired in star or delta configuration. Loose connections to the motor usually result in damage to the controller.
- If the 24 V controller voltage is short circuited or overloaded, the switching power supply will not start up even though the intermediate circuit capacitors are charged. The displays remain turned off. The power supply can only be restarted after eliminating the short circuit or the overload condition.
- Fast running plastic foil doors may produce very high electrostatic charges. A discharge of these voltages may damage the controller. Therefore suitable measures must be taken to prevent electrostatic discharge.
- Turning on or operating the controller in the presence of condensation is not permitted. This can result in the destruction of the controller.
- Before turning on the controllers supply for the first time, ensure that the detector/sensor cards (plug-in modules) have been inserted in the correct locations. Incorrect insertion of the cards can result in damage to the controller, likewise the installation of non-approved third-party equipment.
- Connection cables or cores may only be laid in the area provided for this purpose on the right and upper edge of the board. Avoid combining control circuits (24 V) and power wherever possible.
- Maximum connection diameters for the terminals on printed circuit boards:

	single wire (rigid)	fine wire (with/without wire end ferrule)	Max. tightening torque (Nm)
motor terminals	2.5	2.5	0.5
Line supplies	2.5	1.5	0.5
screw terminals (catch 5 mm)	2.5	1.5	0.5
plug in terminals (catch 5 mm)	1.5	1.0	0.4
plug in terminals (catch 3.5 mm)	1.5	1.0	0.25

6 Product overview

6.1 Housing variants

6.1.1 Housing variant 1 / small housing

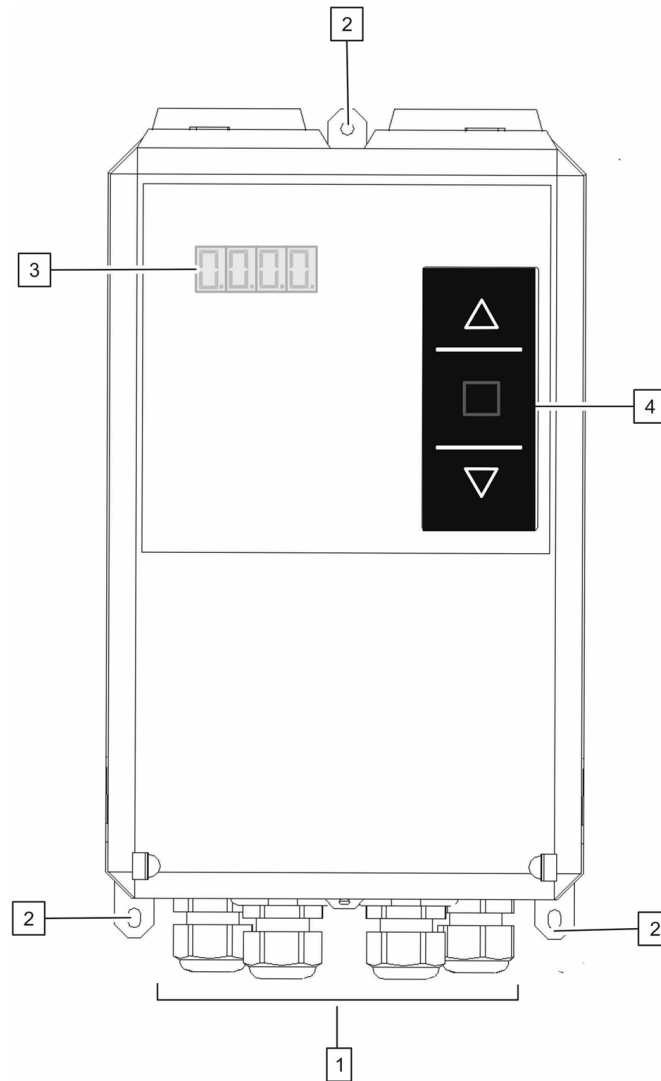
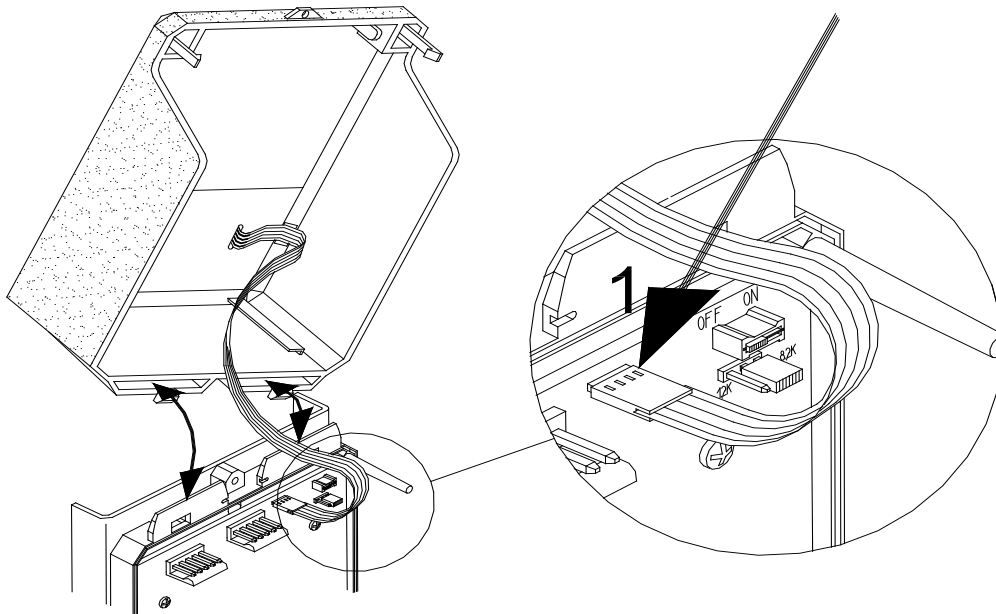

Table 1: Top view housing TST WUE2

Pos.	Description
1	Cable bushing
2	mounting foot
3	7-Segmentdisplay)
4	Foil key pad

i The unit version with 4 kW nominal power cannot be operated in this housing.

6.1.1.1 Installation position of the cover



1. Plug the flat plug of the membrane keyboard into the "Keyboard/Keypad" connector.

6.1.2 Housing variant 2 / large housing

This type of housing is used for controller types TST WUE2-xKGH.

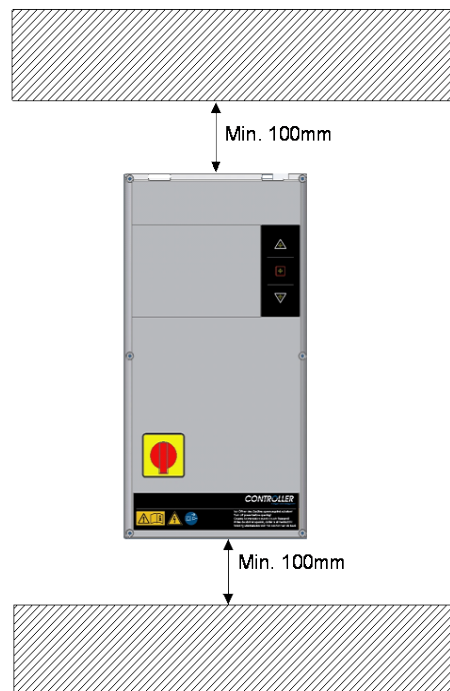

Figure 3: Installation in large housing

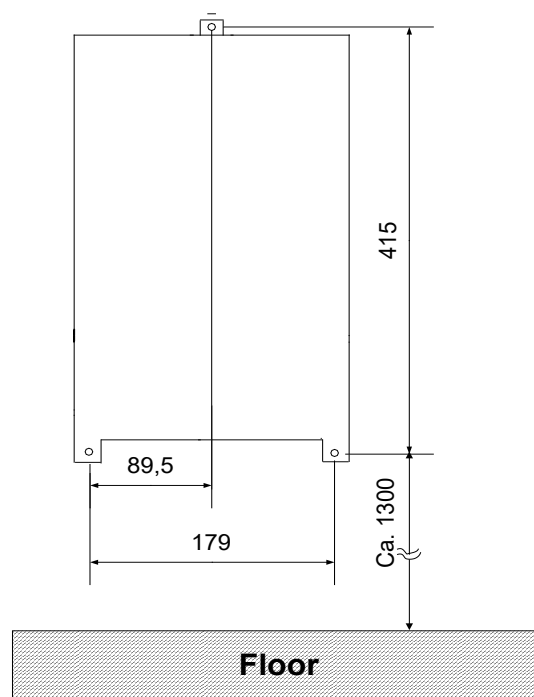

Figure 4: Drilling template large housing

6.1.3 Variants in steel or stainless steel housings

Steel and stainless steel housing variants are also available.
The housing has the following dimensions:

6.1.3.1 300 x 400 mm

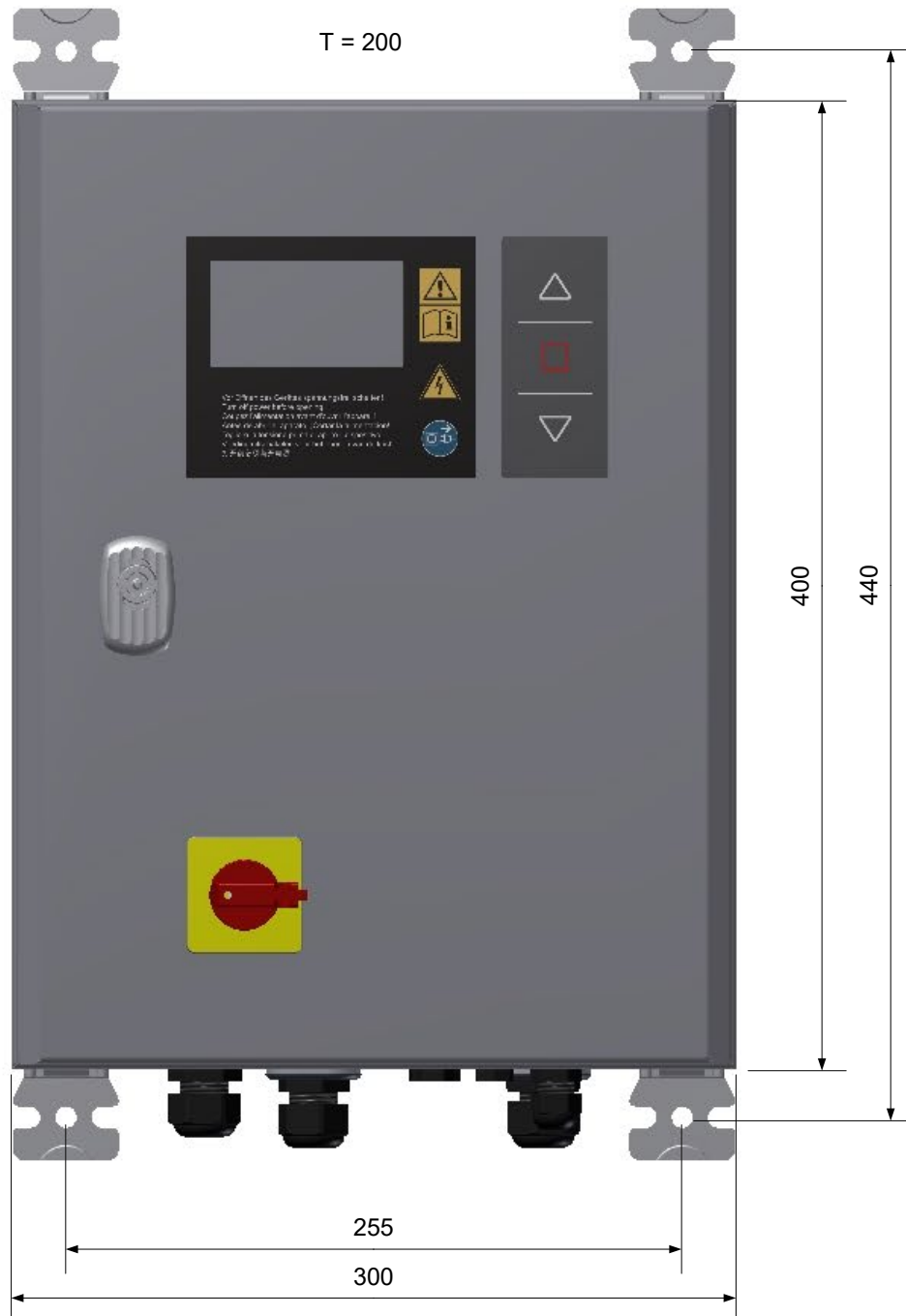

Figure 5: 300 x 400 housing

6.1.3.2 400 x 600 mm



Figure 6: 400 x 600 housing

6.1.3.3 600 x 600 mm



Figure 7: 600 x 600 housing

6.1.4 Hygiene Zone variant

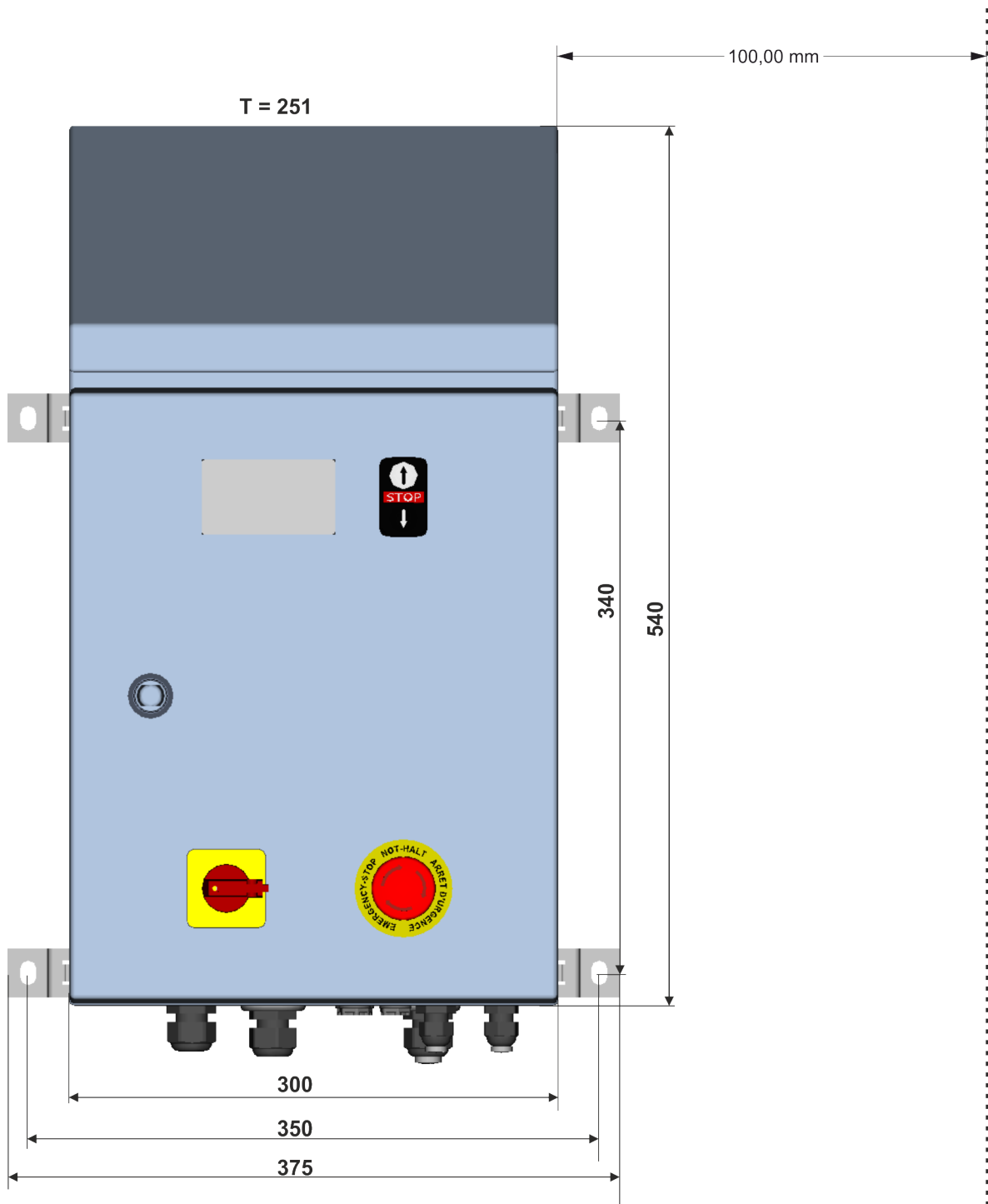

Figure 8: Hygiene housing

6.1.5 Mount the board variant in a steel housing



The mounting adapter is mounted in the steel housing.

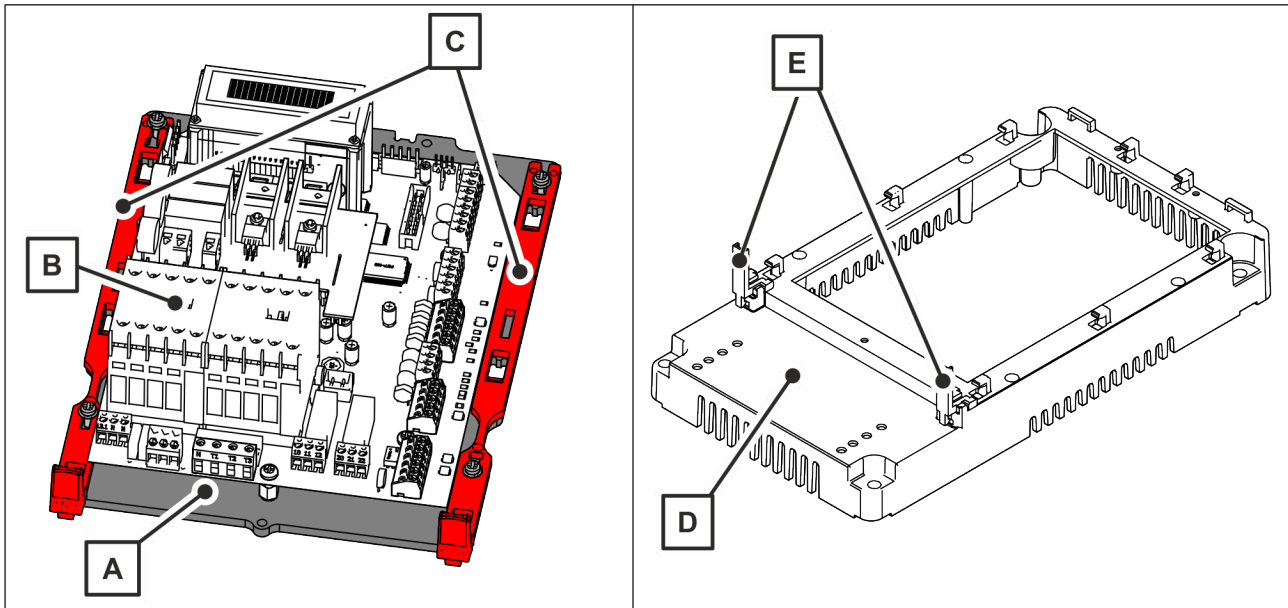
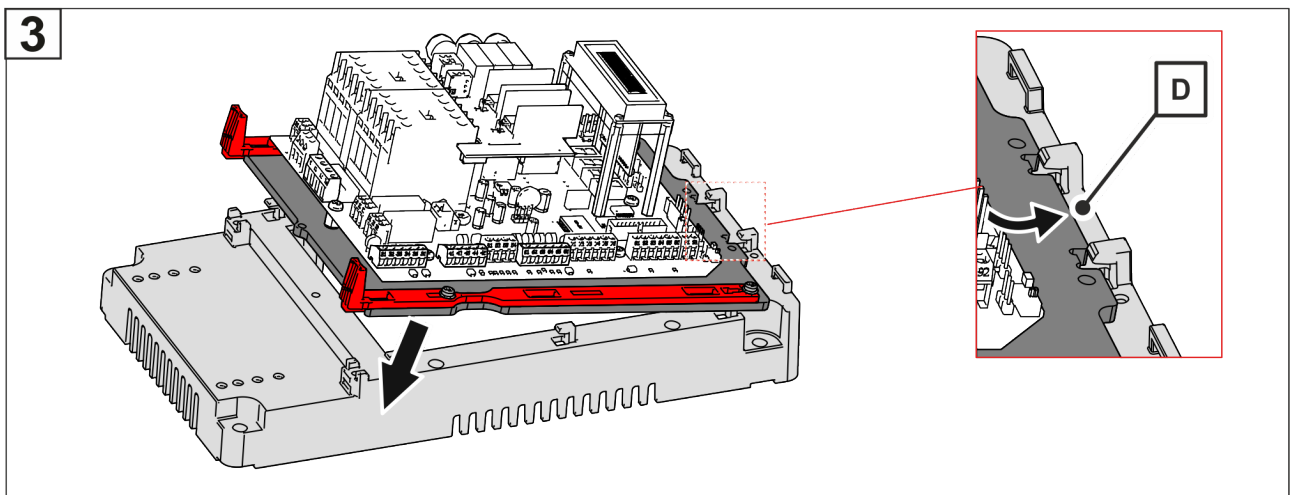
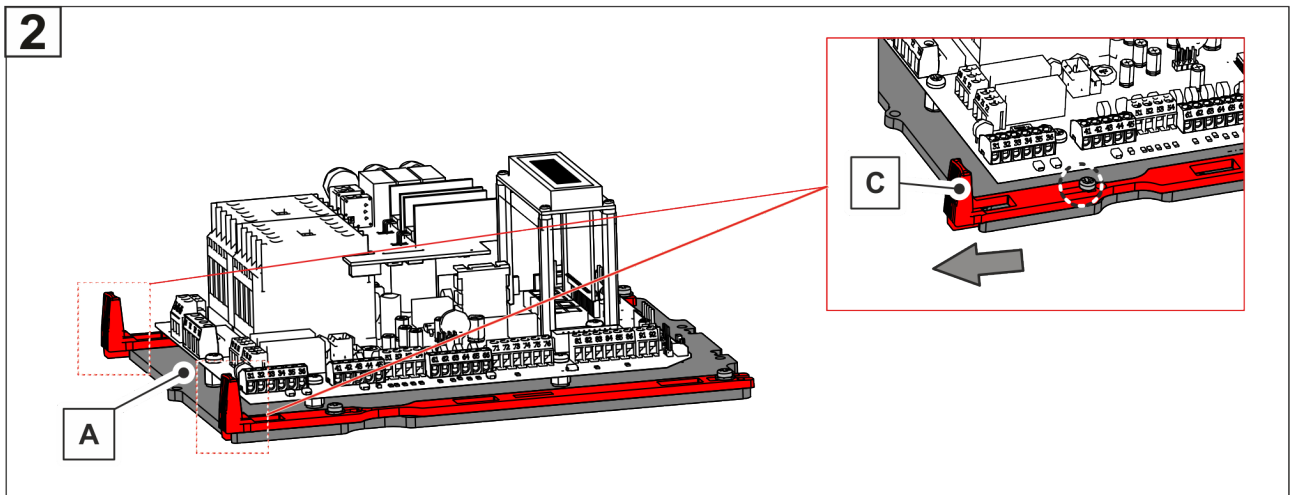
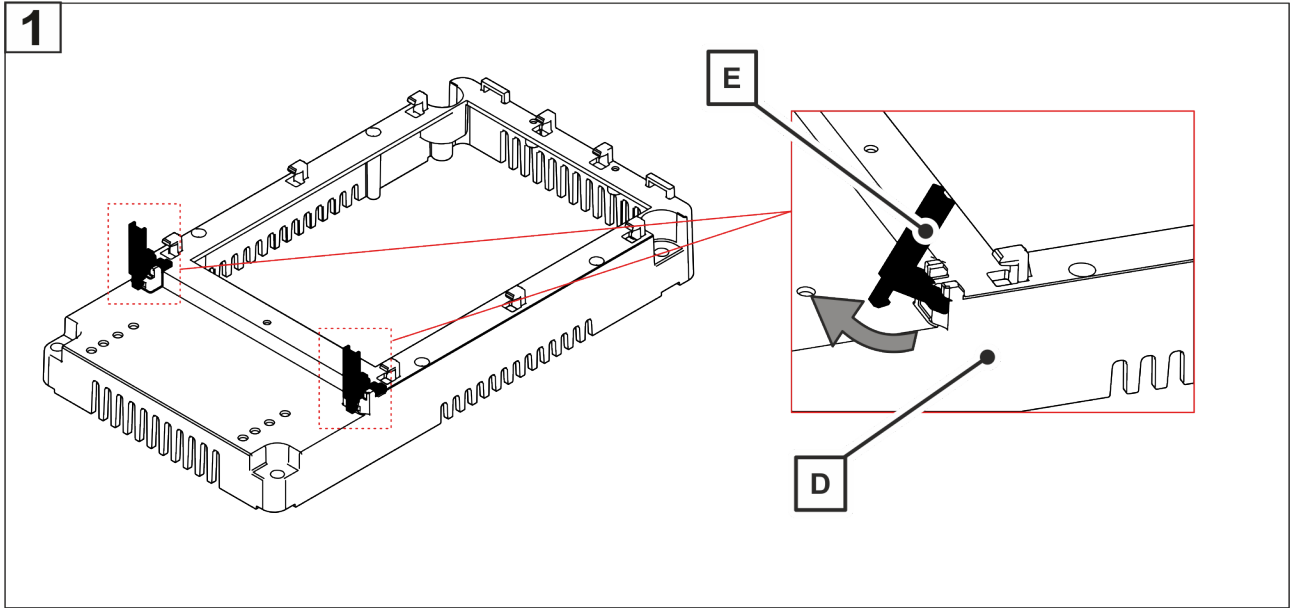
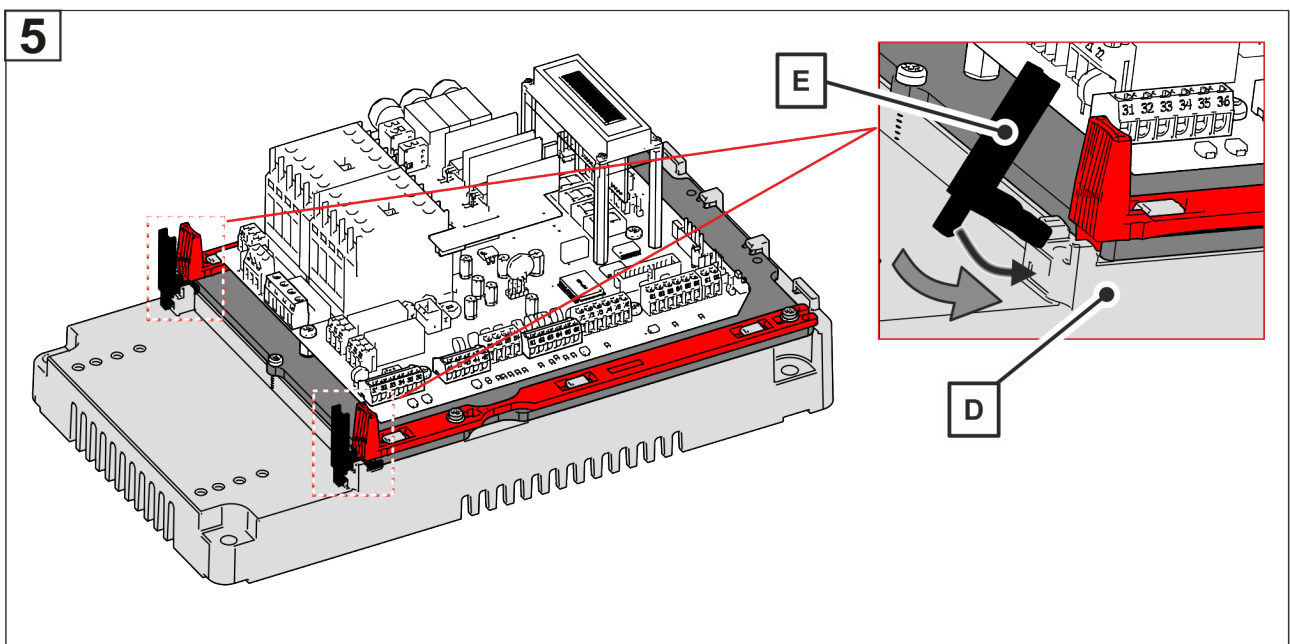
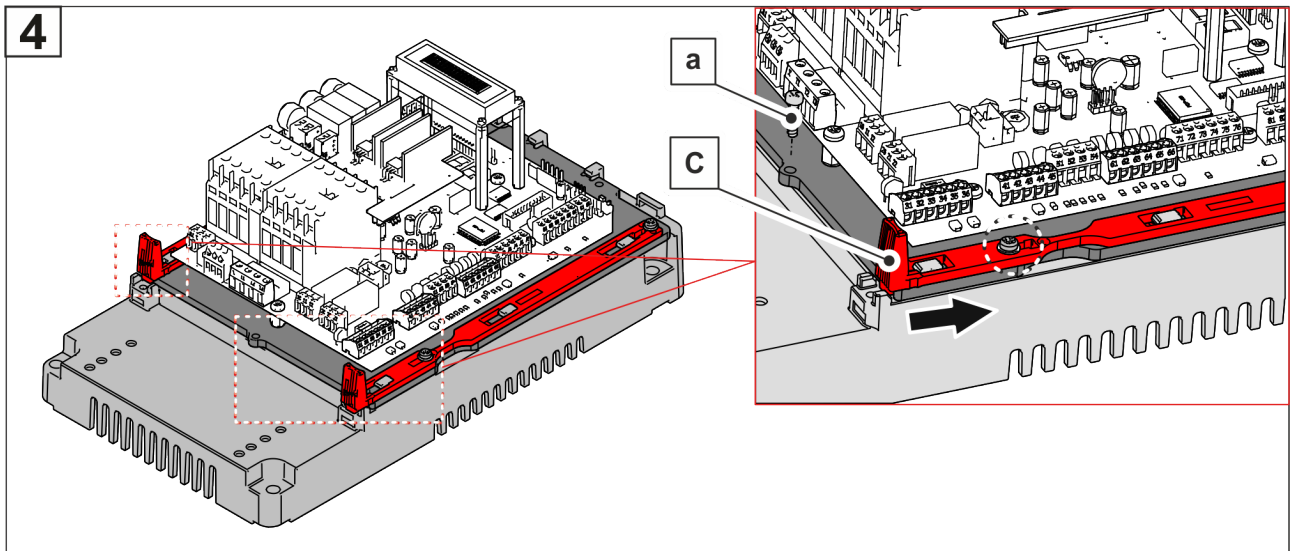

Fig. 1: Board variant and mounting adapter

Position	Description
A	Mounting plate
B	Control unit
C	Slider
D	Mounting adapter (steel housing)
E	Safety clips

Attaching the frame variant with the control unit to the mounting adapter:





1. Remove safety clips (A) from mounting adapter (B).
2. Unlock sliders (C):
 - Pull out both sliders until the screw locks in.
3. Insert board variant in the mounting adapter (B):
 - a. Backward: Hook the board variant in the both retaining brackets.
 - b. Forward: Push down the board variant.
4. Lock slider (C):
 - a. Push in both sliders until they are fixed.
 - b. Fix the board variant with the screw (a) on the mounting adapter.
5. Put the safety clips (A) under the sliders:
 - Press both safety clips (A) in the openings (see pic.5 Detail) of the mounting adapter until they snap into place.

Note: The safety clips are a transport safety. For safety reasons it is necessary to put them again.

6.2 Overview of the TST WUE2

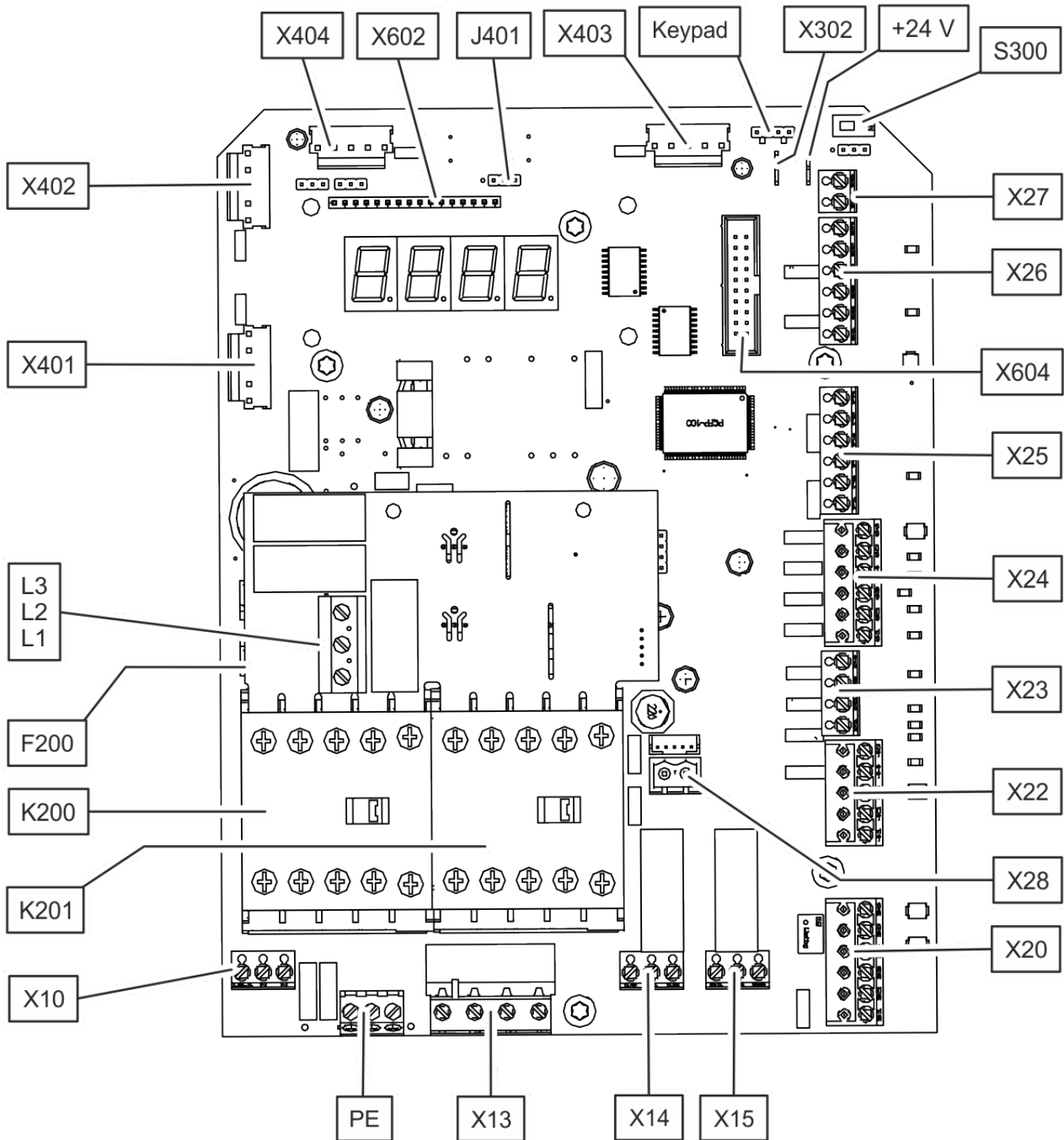

Fig. 1: Top view - Printed circuit board TST WUE2

Table 1: Connection of the TST WUE2

block	Terminal, Connection / Naming
X10	L3.1
	N
	N
K201	Contacteur switch OPEN
K200	Contacteur switch CLOSED
F200	Fuse
L3	L3
L2	L2
L1	L1
X401	Detector, SURA safety edge
X402	Detector, SURA safety edge
X404	Radio
X602	LCD panel
X403	Radio
Keypad	Foil key pad
X302	GND
X301	+24 V for the X604 Connector
S300	Jumper ON/OFF
J401	Jumper digital 1,2 K/8,2 K
X27	91 - GND
	92 - Input 31
X26	81 - GND
	82 - Input 6
	83~ +24 V
	84 - GND
	85 - Input 7
	86~ +24 V
X604	Expansion board
X25	76~ +24 V
	75 - Input 5
	74 - GND
	73~ +24 V
	72 - Input 4
	71 - GND
X24	66~ +24 V
	65 - Input 10
	64 - Input 9
	63 - GND
	62~ +24 V
	61 - Input 8
X23	54 - Input 3
	53 - Input 2
	52 - Input 1
	51~ +24 V
X22	45~ +12 V
	44 - GND
	43 Safety edge
	42 - E-stop external 12
	41 - E-stop external 11

Block	Terminal, Connection / Naming
X28	Internal Emergency-STOP
X20	36 - GND
	35 - Kanal B
	34 - Kanal A
	33~ +12 V
	32 - E-stop external 2
X15	31 - E-stop external 2
	20 - K2 normally open, NO
	21 - K2 Com
X14	22 - K2 normally closed, NC
	10 - K1 normally open, NO
	11 - K1 Com
X13	12 - K1 normally closed, NC
	N
	T1
	T2
PE	T3
	protective conductor

6.2.1 Terminal description

Absolute encoder

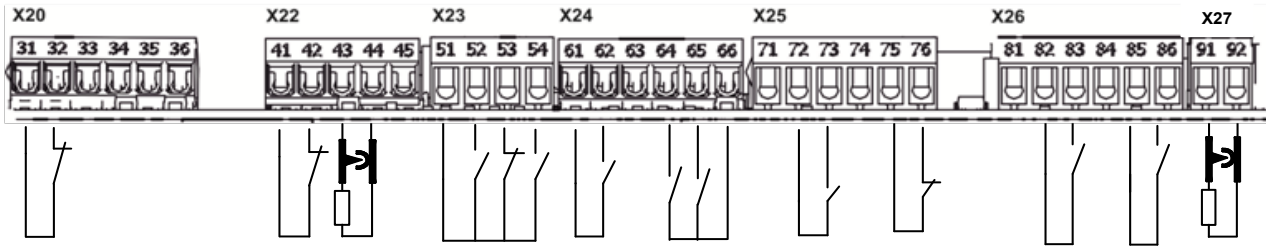

Figure 9: Overview of the relays inputs, absolute encoder

Block	Terminal	Connection / Naming
X20	31	E-stop external 21
	32	E-stop external 22
	33	+12 V
	34	A
	35	B
	36	GND

Block	Terminal	Connection / Naming
X25	71	GND
	72	Input 4 -
	73	+24 V
	74	GND
	75	Input 5 light barrier
	76	+24 V

Block	Terminal	Connection / Naming
X22	41	E-stop external 11
	42	E-stop external 12
	43	Safety Edge
	44	GND
	45	+12 V

Block	Terminal	Connection / Naming
X26	81	GND
	82	Input 6 – constantly open
	83	+ 24 V
	84	GND
	85	Input 7 – Hand/Automatic
	86	+24 V

Block	Terminal	Connection / Naming
X23	51	+24 V
	52	Input 1 - OPEN
	53	Input 2 - STOP
	54	Input 3 - CLOSED

Block	Terminal	Connection / Naming
X27	91	GND
	92	Input 31 – Safety edge

Block	Terminal	Connection / Naming
X24	61	Input 8 – locked in end position CLOSED
	62	+24 V
	63	GND
	64	Input 9 - cross traffic
	65	Input 10 - Deactivation keep open
	66	+24 V

Mechanical limit switches

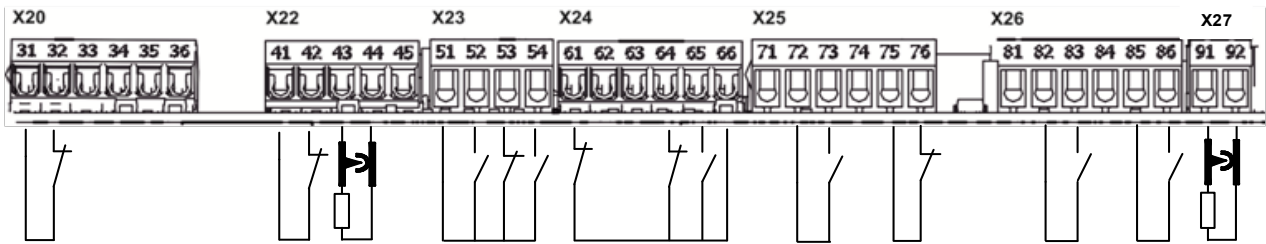

Figure 10: Overview of the relays inputs, mechanical limit switches

Block	Terminal	Connection / Naming
X20	31	E-stop external 21
	32	E-stop external 22
	33	--
	34	--
	35	--
	36	--

Block	Terminal	Connection / Naming
X25	71	GND
	72	Input 4 -single channel, pulse sequence
	73	+24 V
	74	GND
	75	Input 5 light barrier
	76	+24 V

Block	Terminal	Connection / Naming
X22	41	E-stop external 11
	42	E-stop external 12
	43	Safety Edge
	44	GND
	45	+12 V

Block	Terminal	Connection / Naming
X26	81	GND
	82	Input 6 - pre-limit switch Safety Edge
	83	+ 24 V
	84	GND
	85	Input 7 – Limit switch intermediate stop
	86	+24 V

Block	Terminal	Connection / Naming
X23	51	+24 V
	52	Input 1 - OPEN
	53	Input 2 - STOP
	54	Input 3 - CLOSED

Block	Terminal	Connection / Naming
X27	91	GND
	92	Input 31 - extern Safety edge

Block	Terminal	Connection / Naming
X24	61	Input 8 – limit switch open
	62	+24 V
	63	GND
	64	Input 9 – limit switch closed
	65	Input 10 – Deactivation keep open time
	66	+24 V

6.3 Power supply connection



The power plug must be visible and accessible from the control system.

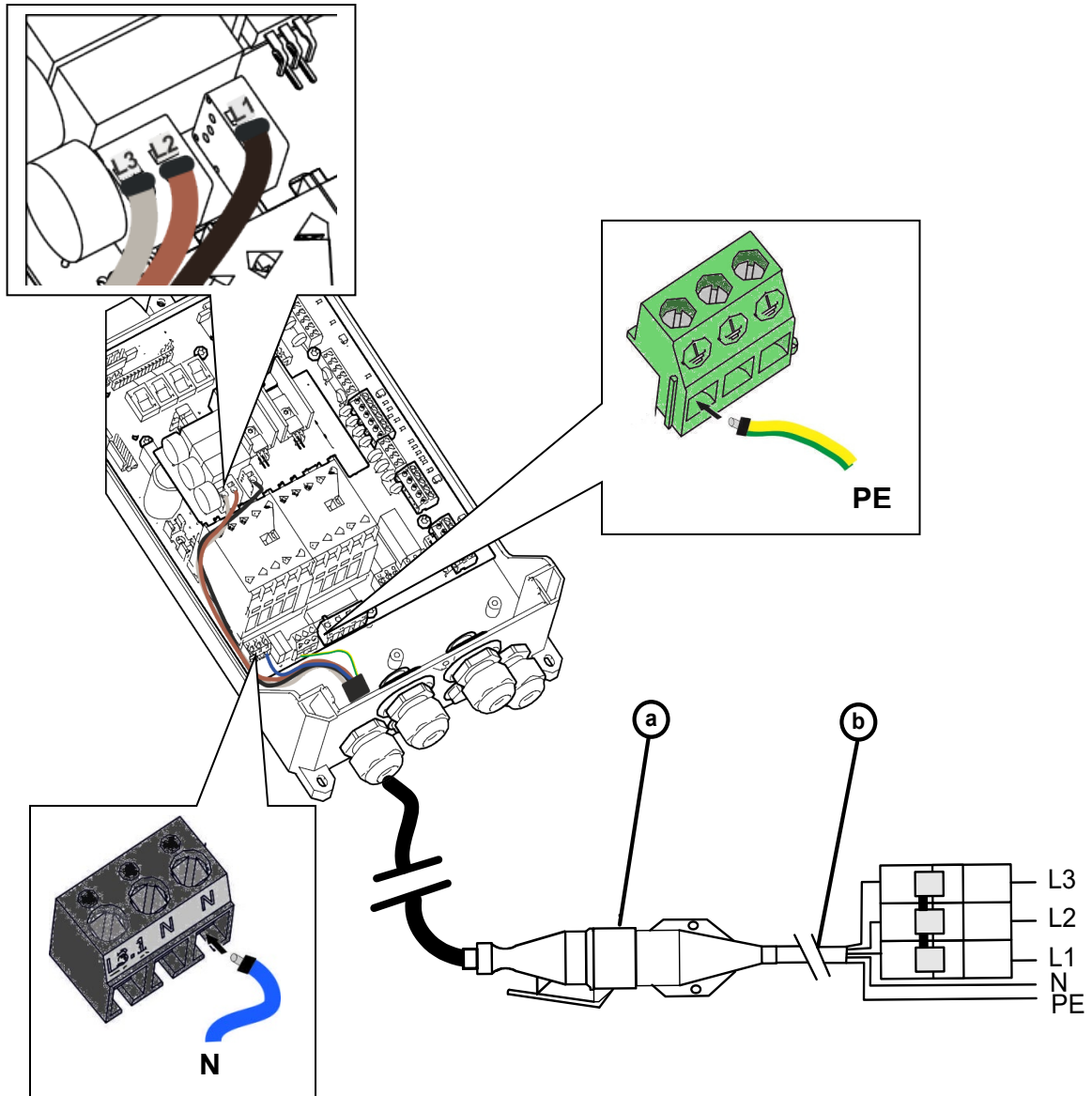

Figure 11: Connecting the power cable

Pos.	Description
a	CEE plug, 5-pole 16 A, red
b	3-Pole fuse, 10 A/Type K



Illustration using the example of the TST WUE2 in a small plastic housing. In housing variants with main switch, the power line must be connected to the main switch.

6.4 Motor and brake connections



In the case of drive units with an electronic brake, ensure that the brake is equipped with adequate suppression. We recommend the use of RC-elements for interference suppression purposes.

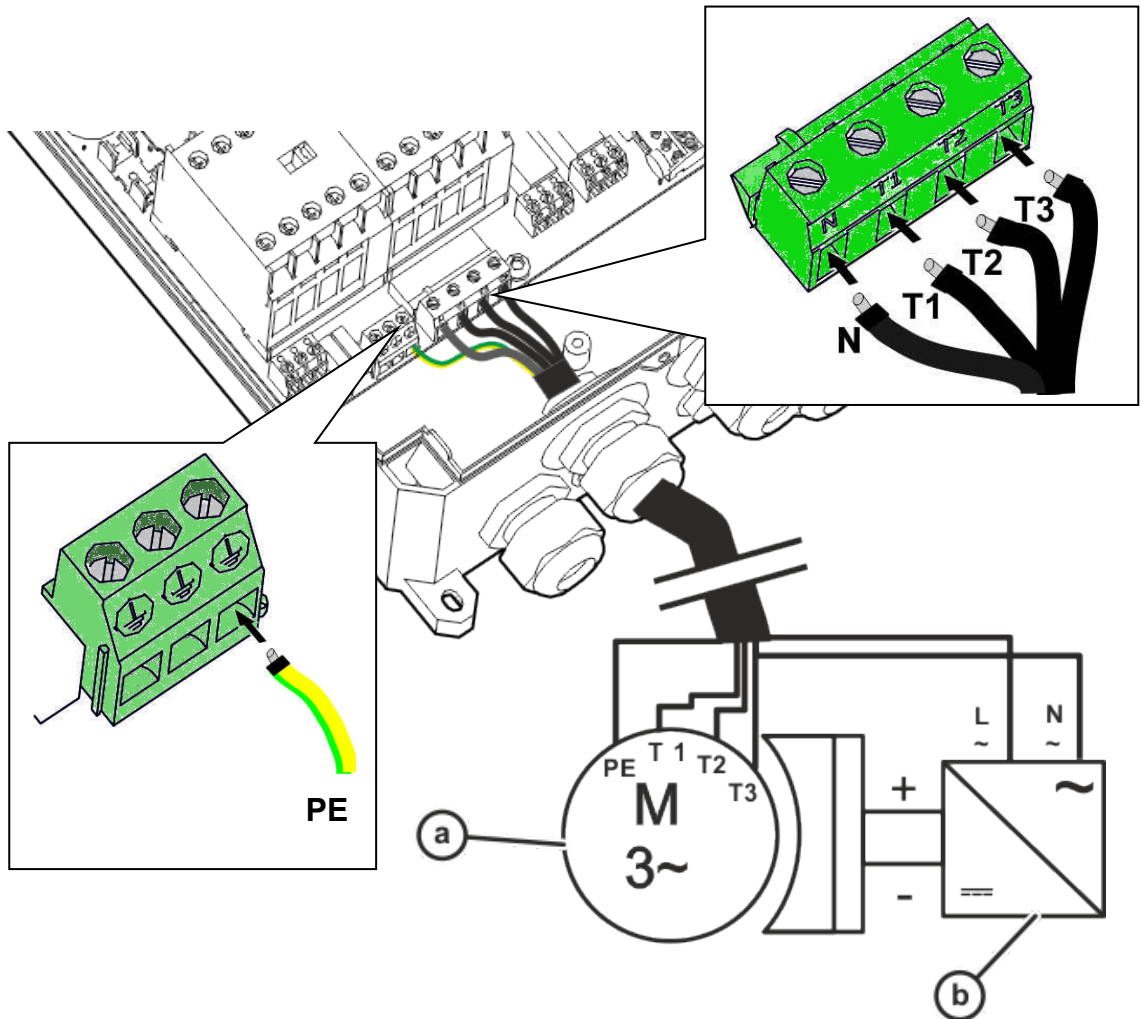

Figure 12: Motor and brake connections

Pos.	Description
a	motor
b	Brake rectifier

6.5 Connection of safety edge

Various types of safety edges can be connected, for example:

- Electrical safety edge with 1.2 k Ω or 8.2 k Ω terminating resistor.
- Dynamical optical system

If one of these types of safety edges is connected when the door control system is switched on it will be recognized automatically.



If no safety edge is connected, automatic closing of the door is not possible.

Use of additional types of safety edges is possible. Please contact the door manufacturer in this respect.

6.5.1 Connection of an electrical safety edge

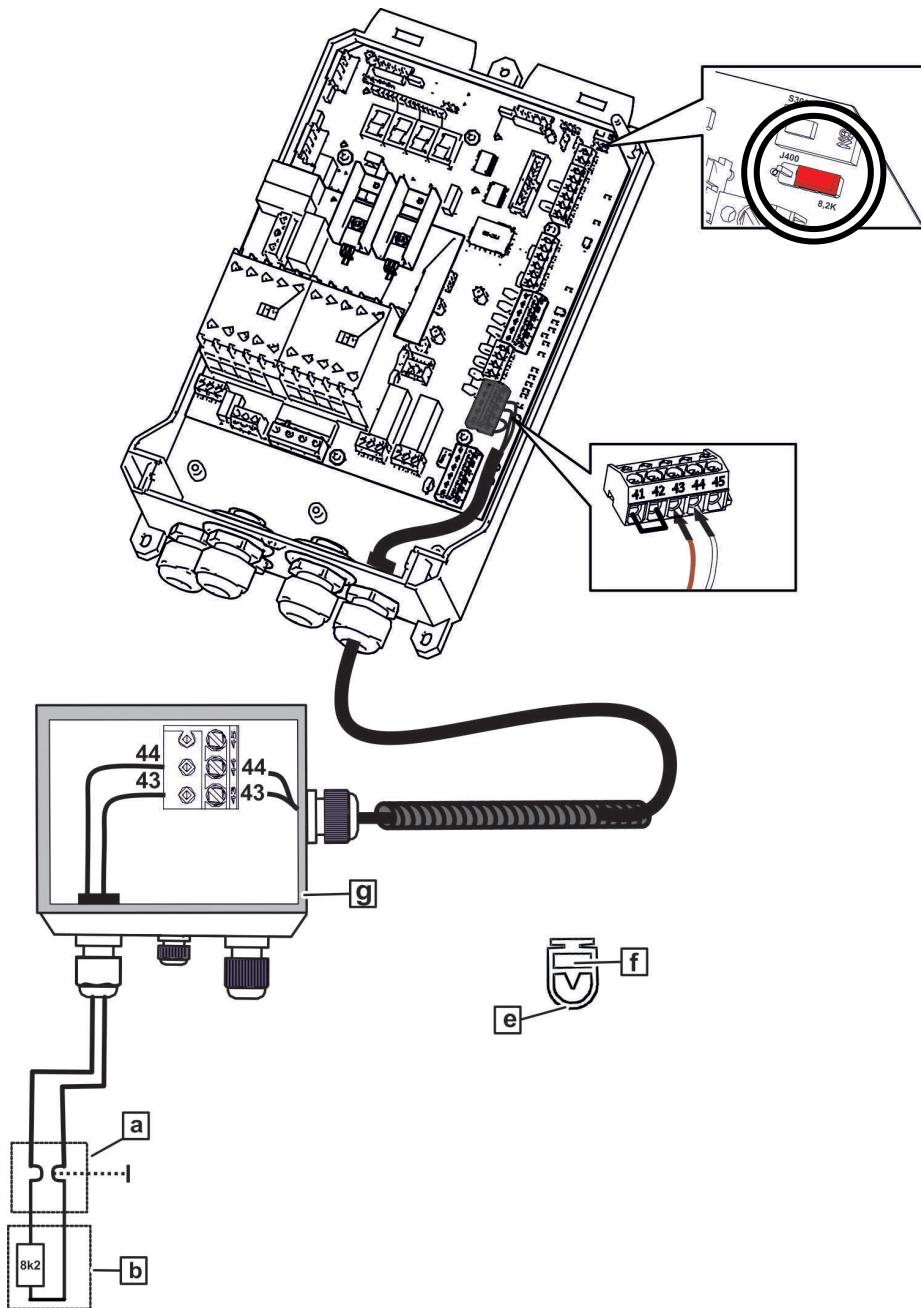

Figure 13: Connection of an electrical safety edge

Pos.	Description
a	Safety Edge: Conductor 43 = brown Conductor 44 = white
b	8k2 termination resistor
e	Cross section safety edge: external
f	Cross section safety edge: internal
g	Terminal box door leaf (example)



For connecting a 1.2K safety edge, set jumper S400 to 1.2.

6.5.2 Connection of an optical safety edge

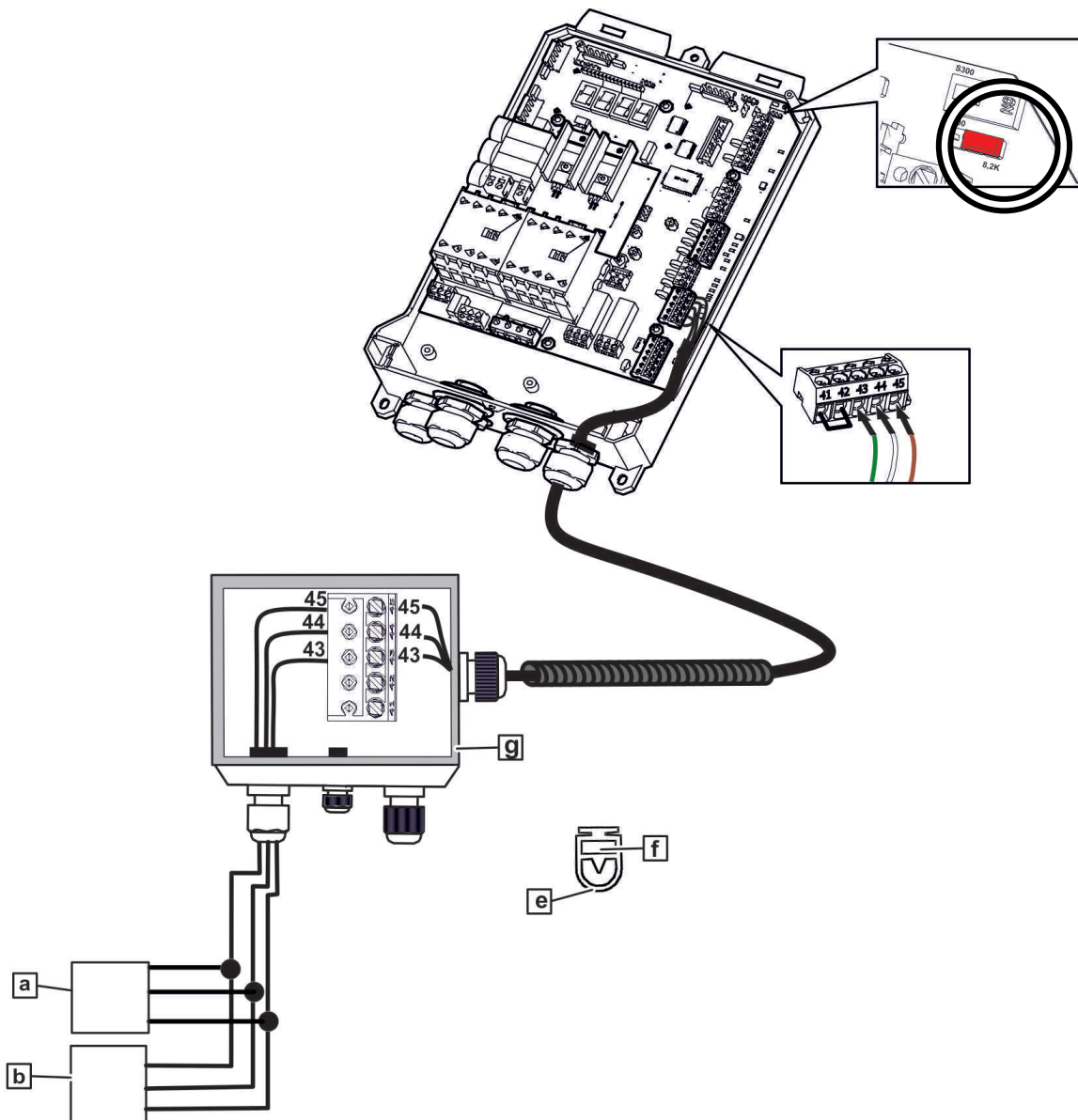

Figure 14: Connection of a dynamical optical safety edge

Pos.	Description
a	Receiver: Conductor 45 = brown Conductor 44 = white Conductor 43 = green
b	Transmitter: Conductor 45 = brown Conductor 44 = white Conductor 43 = green
e	Cross section safety edge: external
f	Cross section safety edge: internal
g	Terminal box door leaf (example)



For connecting a 1.2K safety edge, set jumper S400 to 1.2.

6.6 Safety edge at the 2nd integrated evaluation (input 10)



The 2nd integrated evaluation of termination resistors and optical safety edges is not included in every controller type. Then only a digital input is available.

Input 10 can be used for different connections, for example:

- Dynamical optical system
- Electrical safety edge with 1.2 k Ω or 8.2 k Ω terminating resistor
- Digital input
- slack rope switch/door switch with 8.2 k Ω terminating resistor

Use of additional types is possible. Please contact the door manufacturer in this respect.

6.6.1 Connection of an optical safety edge

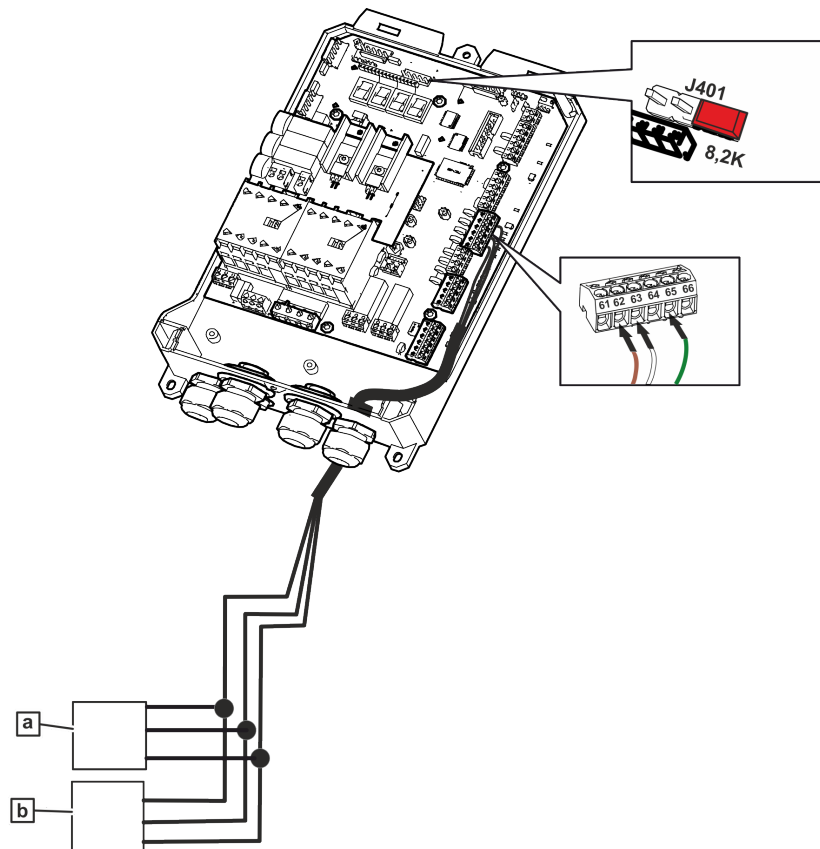

Figure 15: Connection of an optical safety edge

Pos.	Description
a	Receiver: Conductor 62 = brown Conductor 63 = white Conductor 65 = green
b	Transmitter: Conductor 62 = brown Conductor 63 = white Conductor 65 = green



For connecting a 1.2K safety edge, set jumper J401 to 2,3.

6.6.2 Connection of an electrical resistance safety edge

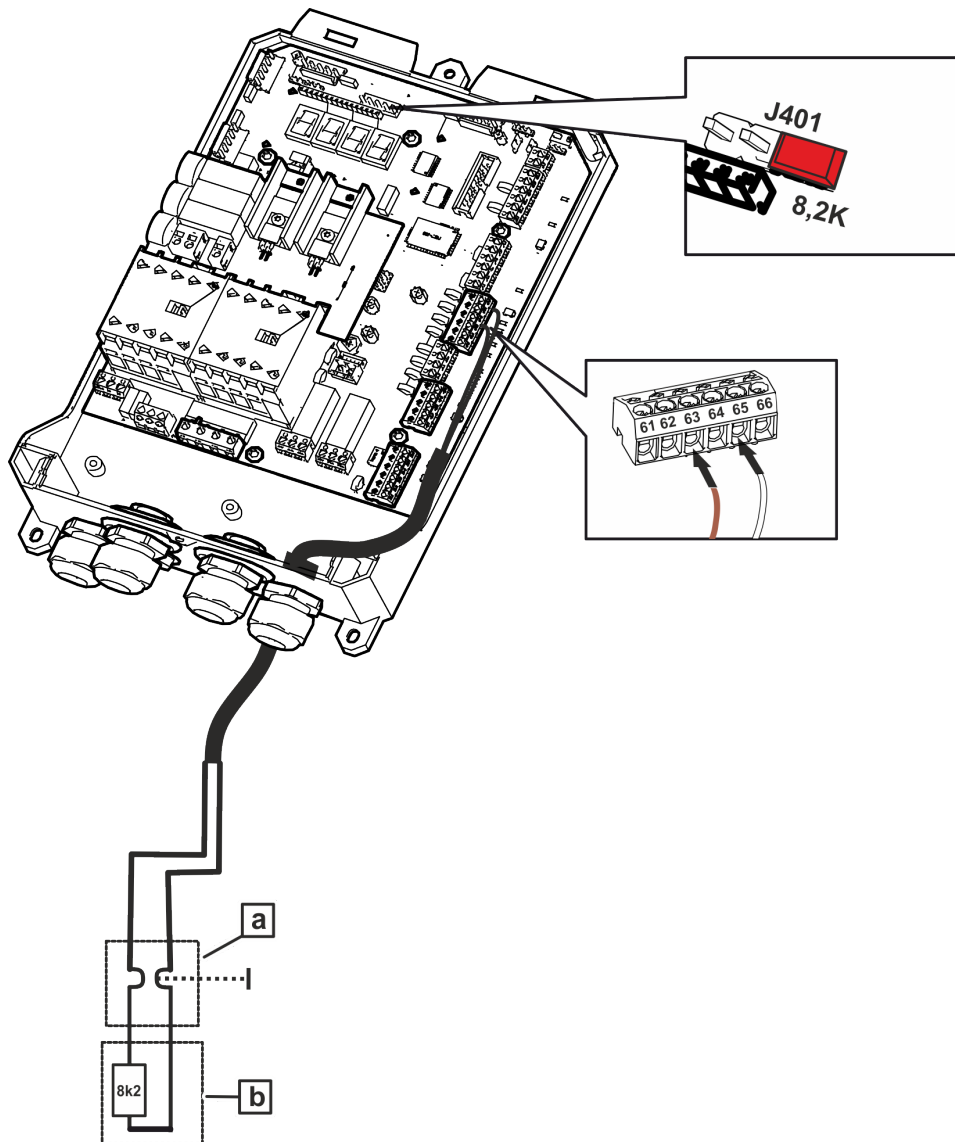

Figure 16: Connection of an electrical resistance safety edge

Pos.	Description
a	Safety Edge: Conductor 63 = brown Conductor 65 = white
b	8k2 termination resistor



For connecting a 1.2K safety edge, set jumper J401 to 1.2.

6.6.3 Connection of a digital input

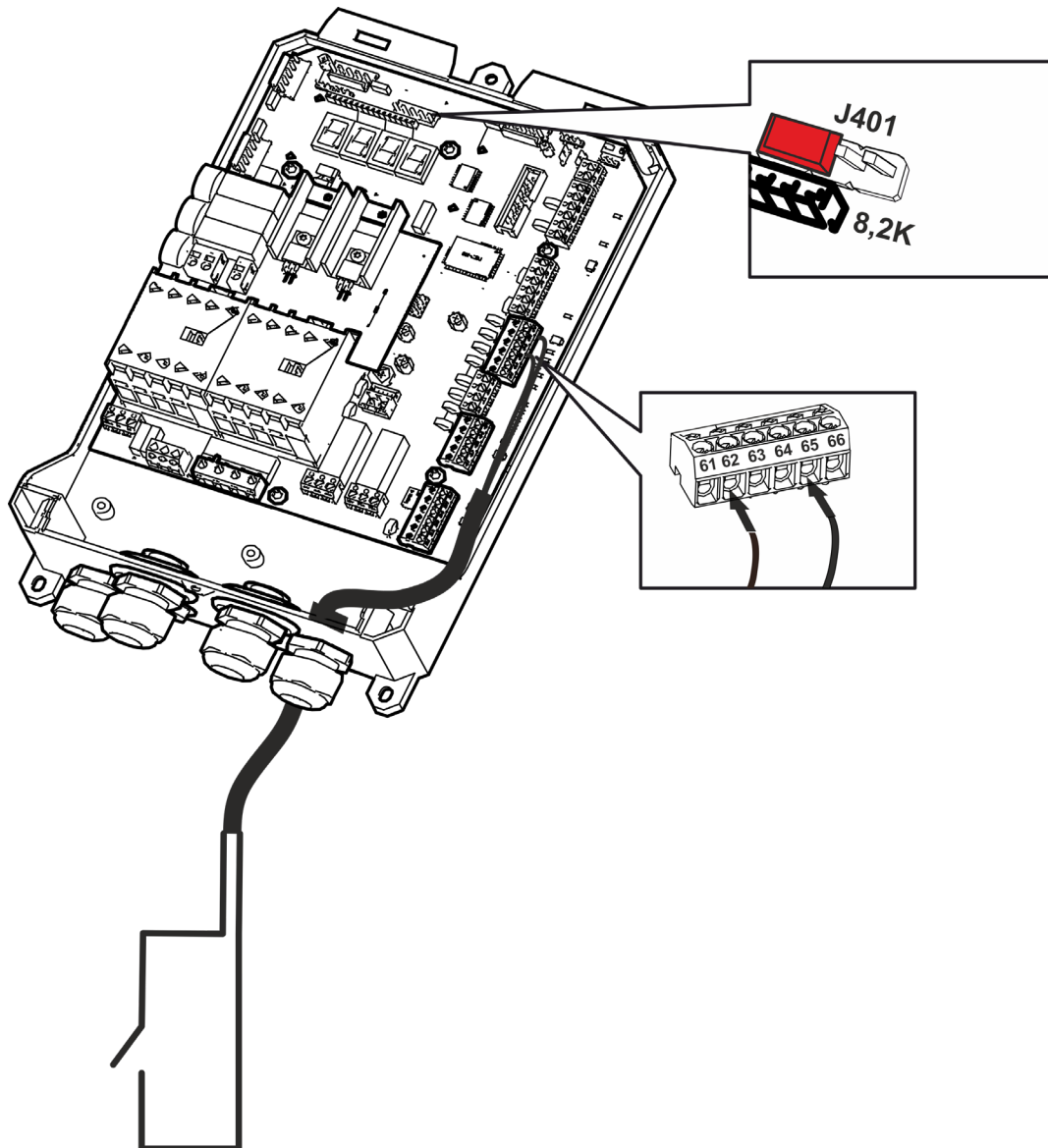

Figure 17: Connection of an electrical resistance safety edge



For connecting a 1.2K safety edge, set jumper J401 to 3,4.

6.6.4 Connection of a slack rope switch/door switch



- Lay the short, unprotected cables, which lead to the slack rope switches and which are not cross-fault monitored, in protective tubes or protective hoses!
- Place the cable in the door leaf.

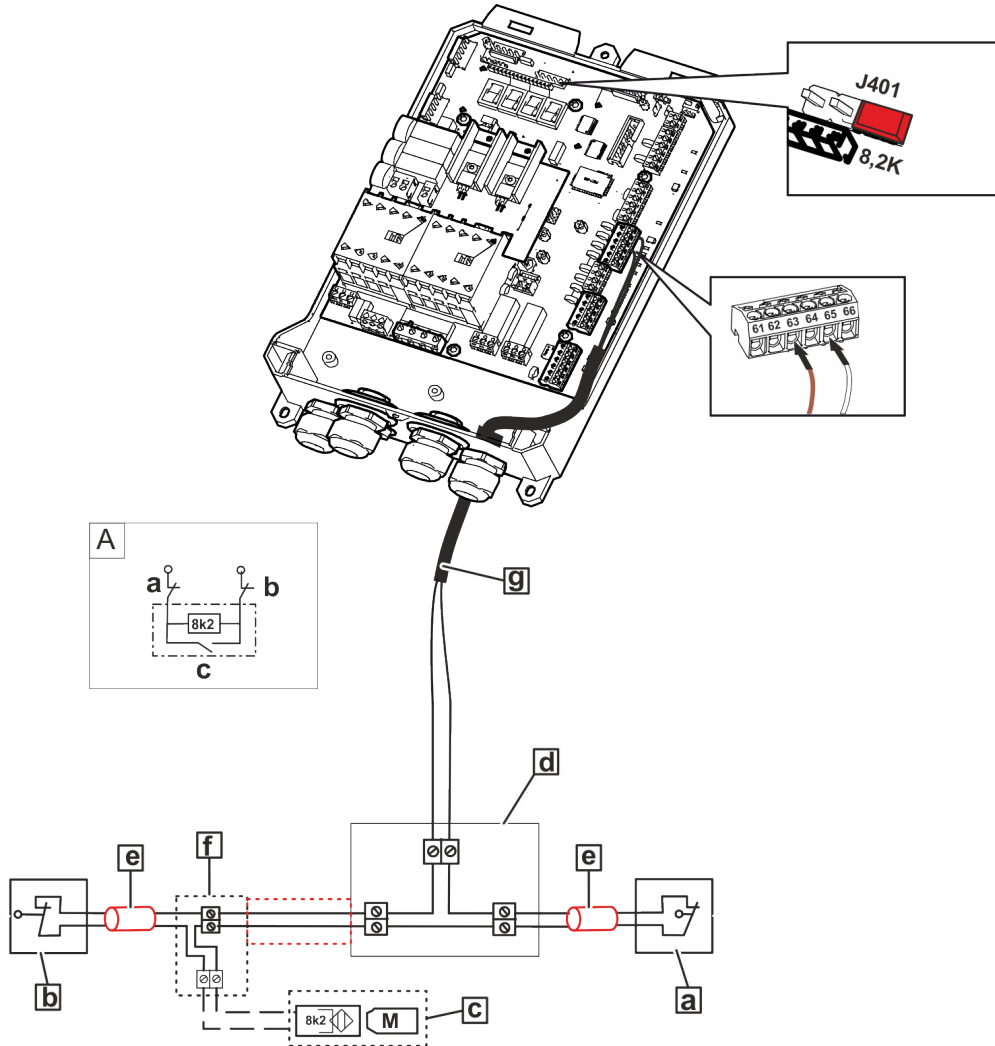

Figure 18: Connection of an electrical resistance safety edge
 Figure A: Simplified circuit

Pos.	Description
a	slack rope switch 1: Conductor 63 = brown
b	slack rope switch 2: Conductor 65 = white
c	door switch with magnet (M)
d	Terminal box door leaf (example)
e	protective tube
f	connection box (example)
g	helix cable

6.7 Light curtain TST LGB

The light curtain TST LGB can be used as the sole safety device. Please make sure that the door blade completely covers the light lines of the light curtain.

The TST LGB also permits the automatic teach-in of the end position CLOSED.



Optionally, the TST LGB can assume other functions. In these cases, additional safety devices must be installed on the door.

6.7.1 Installation of the TST LGB

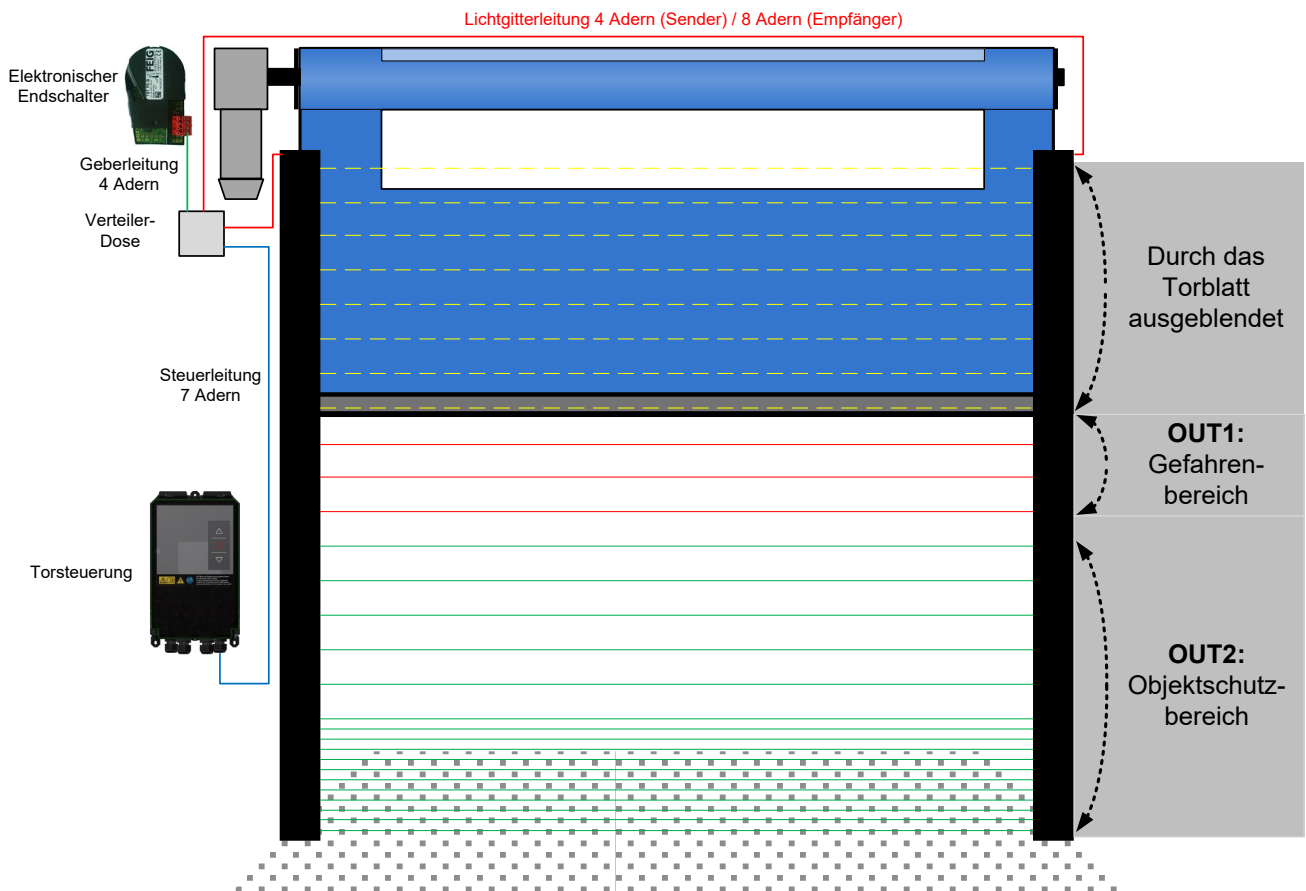

Figure 19: Wiring example

6.7.2 Connection of the TST LGB

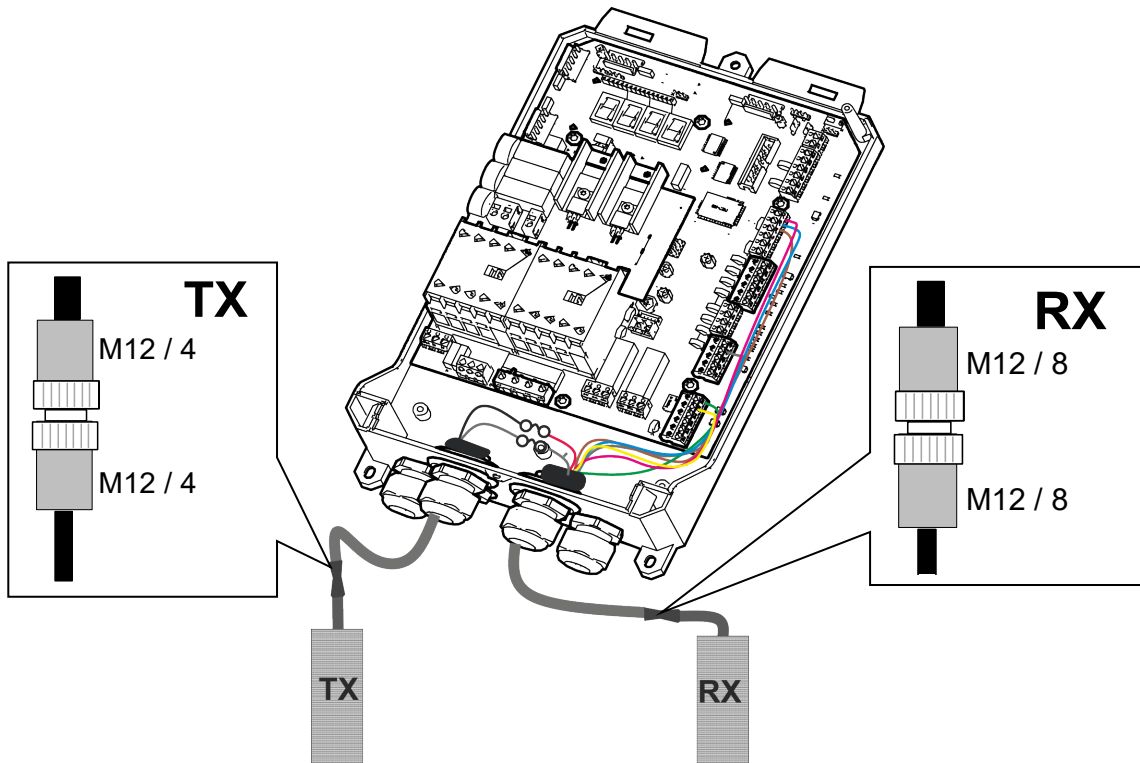
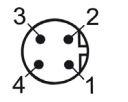



Figure 20: Overview of the TST LGB connections

Table 2: Transmitter pin labels Table 3: Terminal marking controller

Connection	Pin	Colour	Connection Naming
Transmitter (TX) 	1	brown	+ 24 VDC
	2	white	RS485 B- (LGB-RX)
	3	blue	GND
	4	black	RS485 A+ (LGB-RX)

Block	Terminal	Connection / Naming
X20	34	RS485 A – channel A
	35	RS485 B – channel B
X22	43	safety edge – OUT 1
X25	73	+24 V
	74	GND
	75	Input 5 – light barrier OUT2

Table 3: Pin assignment receiver

Connection	Pin	Colour	Connection / Naming
Receiver (RX) 	1	white	RS485 B- (LGB-TX)
	2	brown	+ 24 VDC
	3	yellow	RS485 A+ (TST)
	4	Green	RS485 B- (TST)
	5	grey	OUT 1 - safety edge
	6	pink	OUT 2 – light barrier
	7	blue	GND
	8	red	RS485 A+ (LGB-TX)

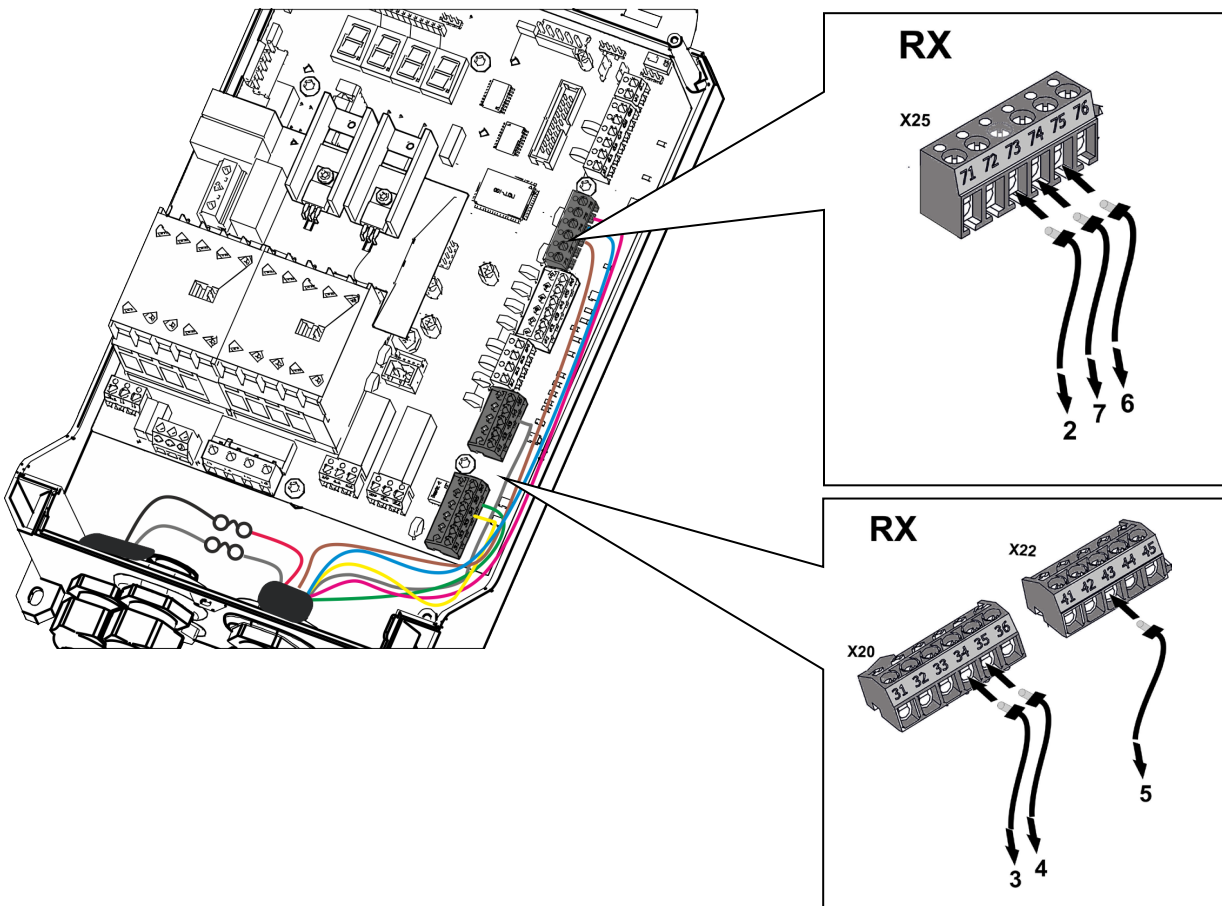

1. Connectin receiver (RX):

Pin	Colour	Terminal
2	brown	73
7	blue	74
6	pink	75
3	yellow	34
4	Green	35
5	grey	43

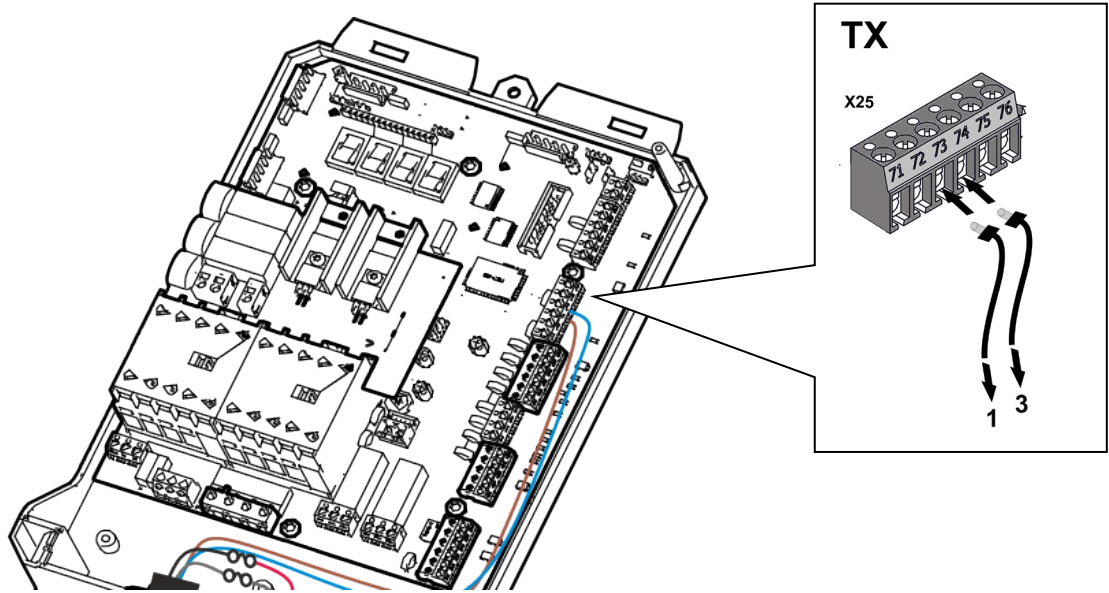

2. Connecting transmitter (TX):

Pin	Colour	Terminal
1	brown	73
3	blue	74

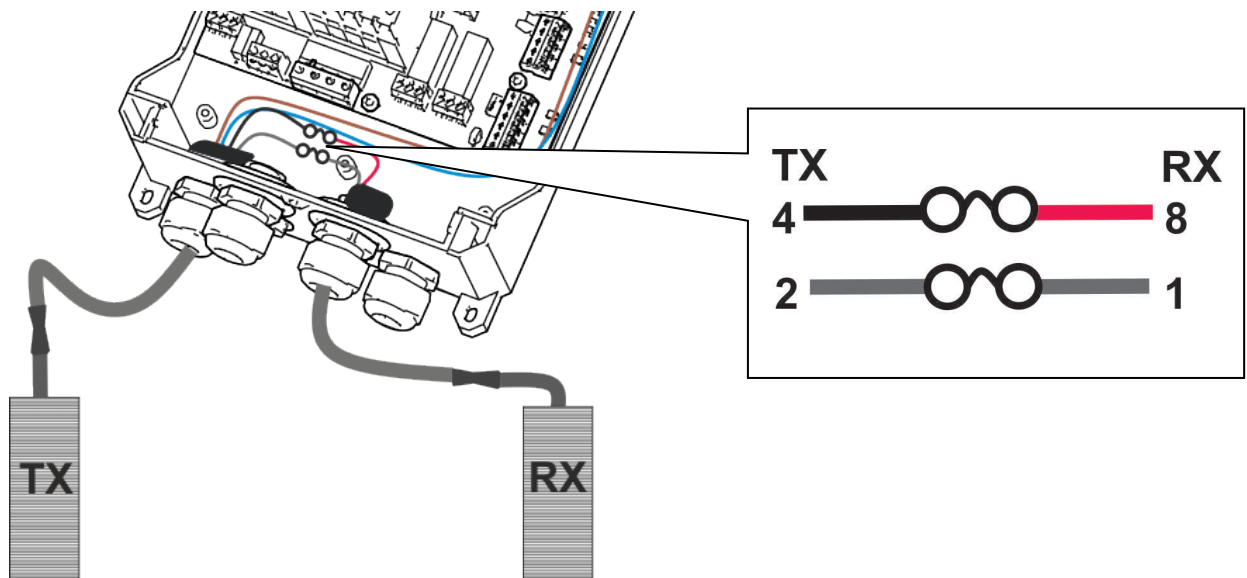

3. Connect the transmitter (TX) to the receiver (RX) within the door controller:

Transmitter (TX)		Receiver (RX)	
Colour	Wire	Wire	Colour
black	4	8	red
white	2	1	white

6.8 Wiring diagram of the Wiring board TST RLGxA

The TST RLGxA wiring board is a terminal distributor which facilitates the connection between the light curtain TST LGB and the door controller.

Overview Wiring diagram TST RLGxA

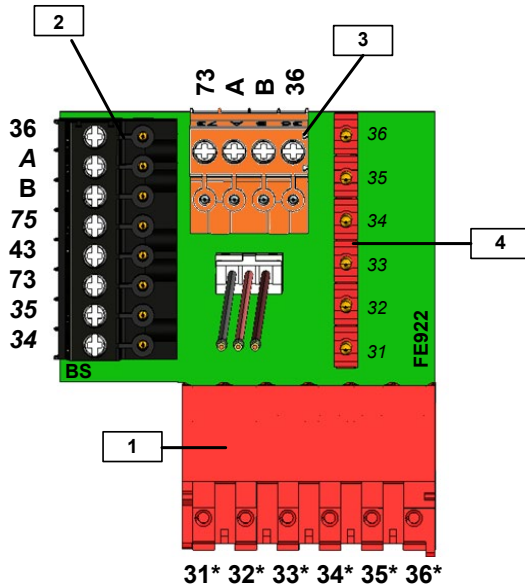

Table 4: Terminal marking TST RLGxA

Pos.	Terminal	Connection / Naming
1	31*	E-stop external 21
	32*	E-stop external 22
	33*	+12 V
	34*	A
	35*	B
	36*	GND

Pos.	Terminal	Connection / Naming
3	73	+24 V
	A	RS485 A LGB
	B	RS485 B LGB
	36	GND

Pos.	Terminal	Connection / Naming
2	36	GND
	A	RS485 A LGB
	B	RS485 B LGB
	75	Input 5 light barrier
	43	Safety Edge
	73	+24 V
	35	Channel B
	34	Channel A

Pos.	Terminal	Connection / Naming
4	31	E-stop external 21
	32	E-stop external 22
	33	+12 V
	34	A
	35	B
	36	GND

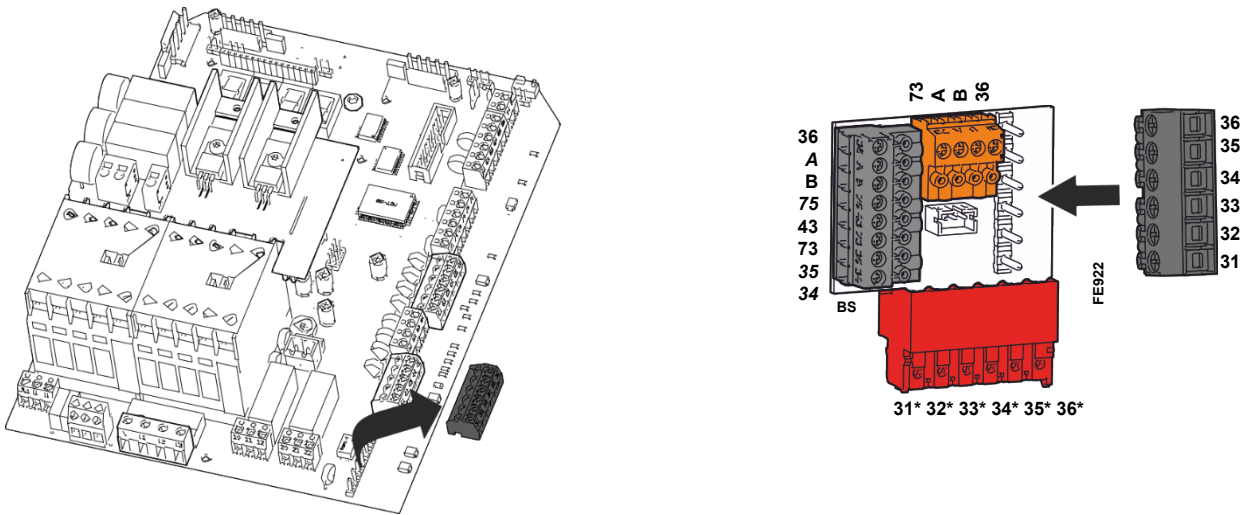

1. Terminal X20 (terminal no 31-36) disconnect from the controller.
2. Terminal X20 (terminal no. 31-36) onto the pin strip FE922 of the wiring board.

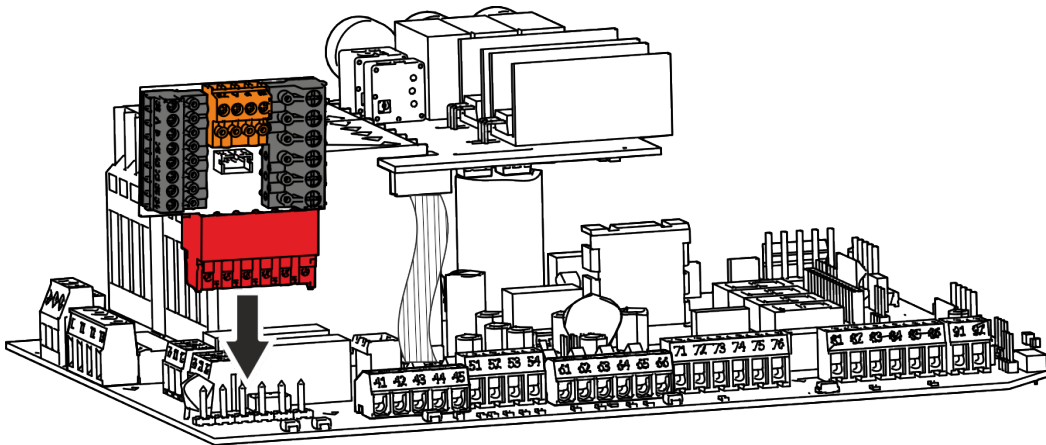

3. Plug the wiring board with the red clamp onto the red pin header X20 of the position encoder.

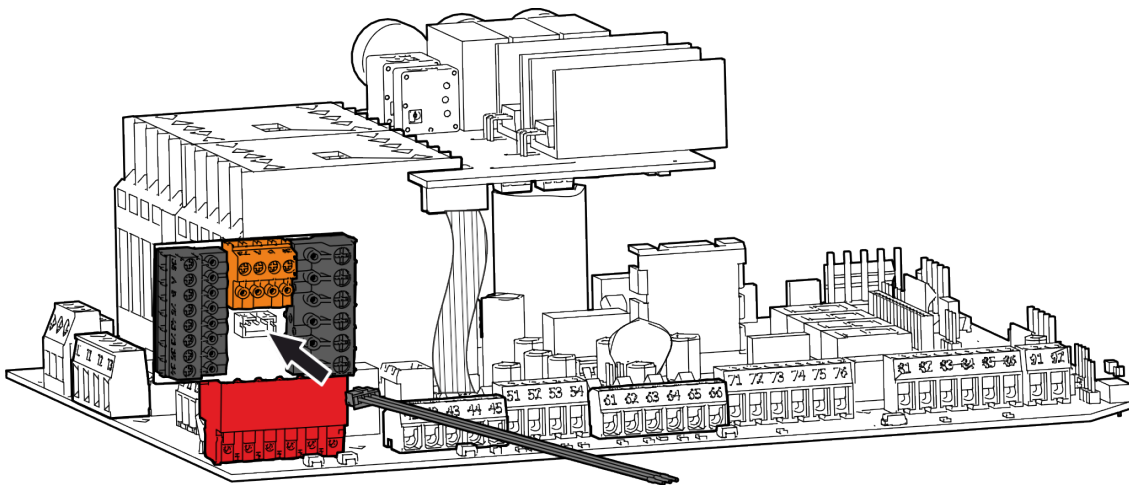

4. Connect the cable to the wiring board.

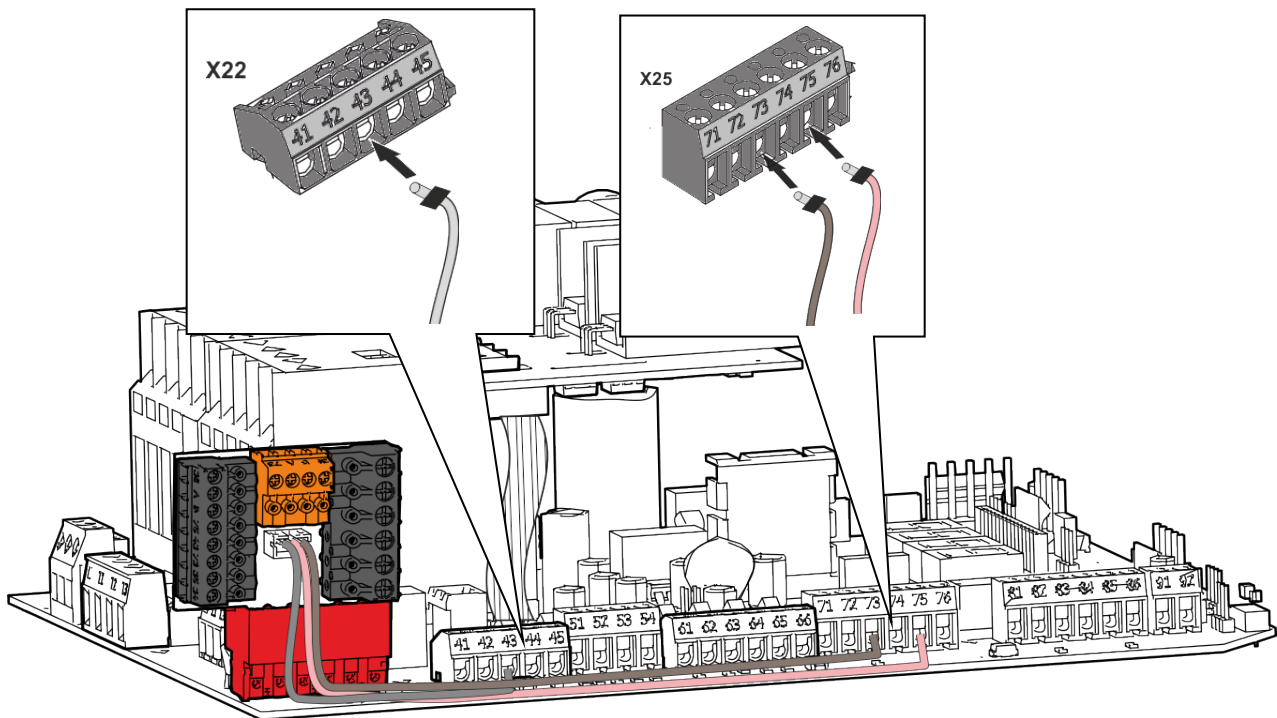

5. Connect the brake rectifier cables to terminals X22 and X25.

TST RLGxA	TST WUE2	
Wire	Block	Terminal
grey	X22	43
pink	X25	75
brown	X25	73



ACHTUNG! The contacts can bend!

Before tightening the connection screw, remove the plugs from the wiring board.

6. For the connection of the limit switches and the light curtain connection: see TST wiring board **TST RLGxA wiring board Assembly and Wiring diagram**.

6.9 Limit switch connection

Different limit switch systems can be used with the TST WUE2 door control system.

For example, you can use an absolute encoders as limit switches or mechanical cam limit switches.

Cam limit switches can be used.



ATTENTION
Compliance with the safety function in accordance with EN 12453:2017 requires the use of a position encoder with PL "c", minimum cat. 2 in accordance with EN 13849-1.

6.9.1 Absolute encoder TST PE FSP with WICAB system

Absolute encoder TST PE FSB is a single-turn encoder which is equipped with the WICAB radio system. The driving shaft must not execute more than a single revolution over the entire path of the door.

The WICAB system can be employed to replace the spiral cable with a wireless link. For this purpose, a mobile unit TST FSBM must be mounted on the door leaf.

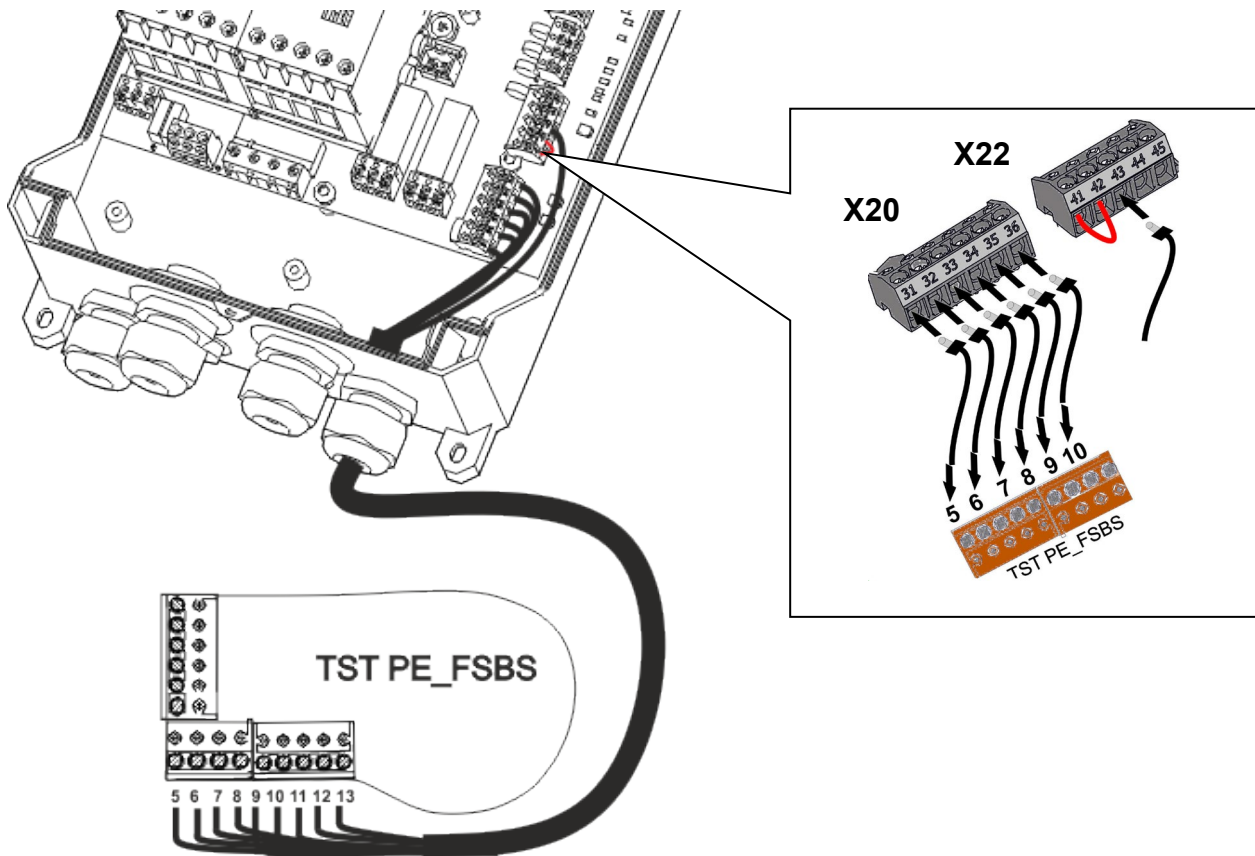

Figure 21: Absolute encoder TST PE-FSBS

Connection	Terminal no. /Assignment
TST PE-FSBS	5 Emergency stop output
	6 Emergency stop output
	7 +12 VDC
	8 RS 485-A
	9 RS 485-B
	10 GND
	11 Output 1
	12 Output 2
	13 +24 VDC optional
	20 Emergency hand control
21 Emergency hand control	
22 thermo switch	
25 Emergency stop 3	

Block	Terminal no. /Assignment
X20	31 E-stop external 21
	32 E-stop external 22
	33 +12 VDC
	34 RS 485-A
	35 RS 485-B
	36 GND

Block	Terminal no. /Assignment
X22	41 Jumper
	42 Jumper
	43 Safety Edge

6.9.2 Absolute encoder TST PD

Absolute encoder TST PD is a multi-turn encoder. Due to a selectable transmission ratio, this encoder can be used for both very fast (e.g. motor shaft) as well as very slow shafts (e.g. door shaft). The driving shaft may execute more than a single revolution.

This encoder may also be equipped with the WICAB radio system to transfer the status of the safety edge without a spiral cable. For this purpose, the stationary unit TST PD FSAS and the mobile unit TST FSAM are required.

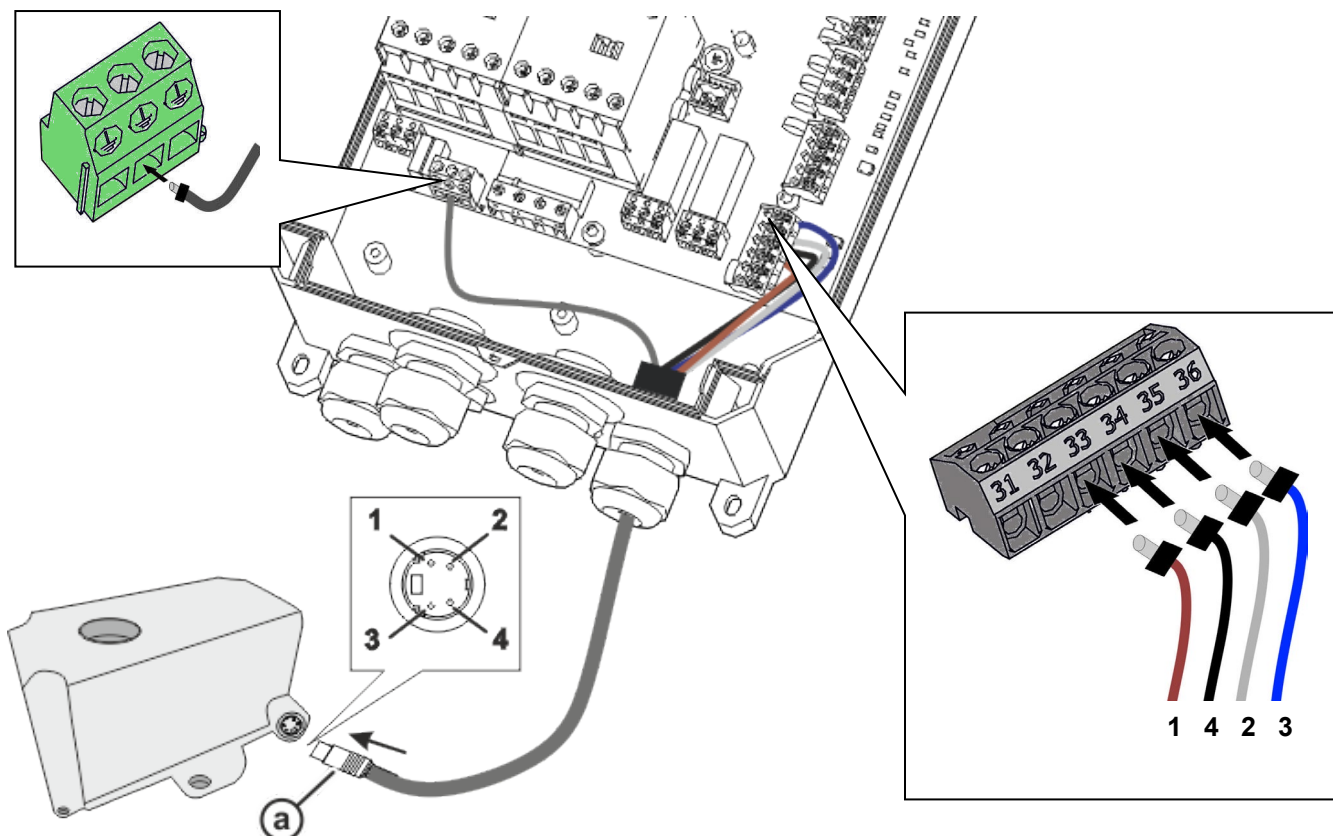

Figure 22: Connection of absolute encoder PD

Pin	Description	
1	M8 Connector 4 pole	+12 V
2		RS485 B
3		GND
4		RS485 A

Pos.	Description	
a	M8 4-pole socket	Min. IP 65 Gold-plated contacts

Connection TST PD		
TST PD		Terminal number
Pin	Colour	
1	brown	33
2	white	35
3	blue	36
4	black	34
Shield		PE

6.9.3 Absolute encoder DES



Example of use!

Please also observe the information in chapter 3 Safety functions in accordance with EN 12453:2017 on page 12.

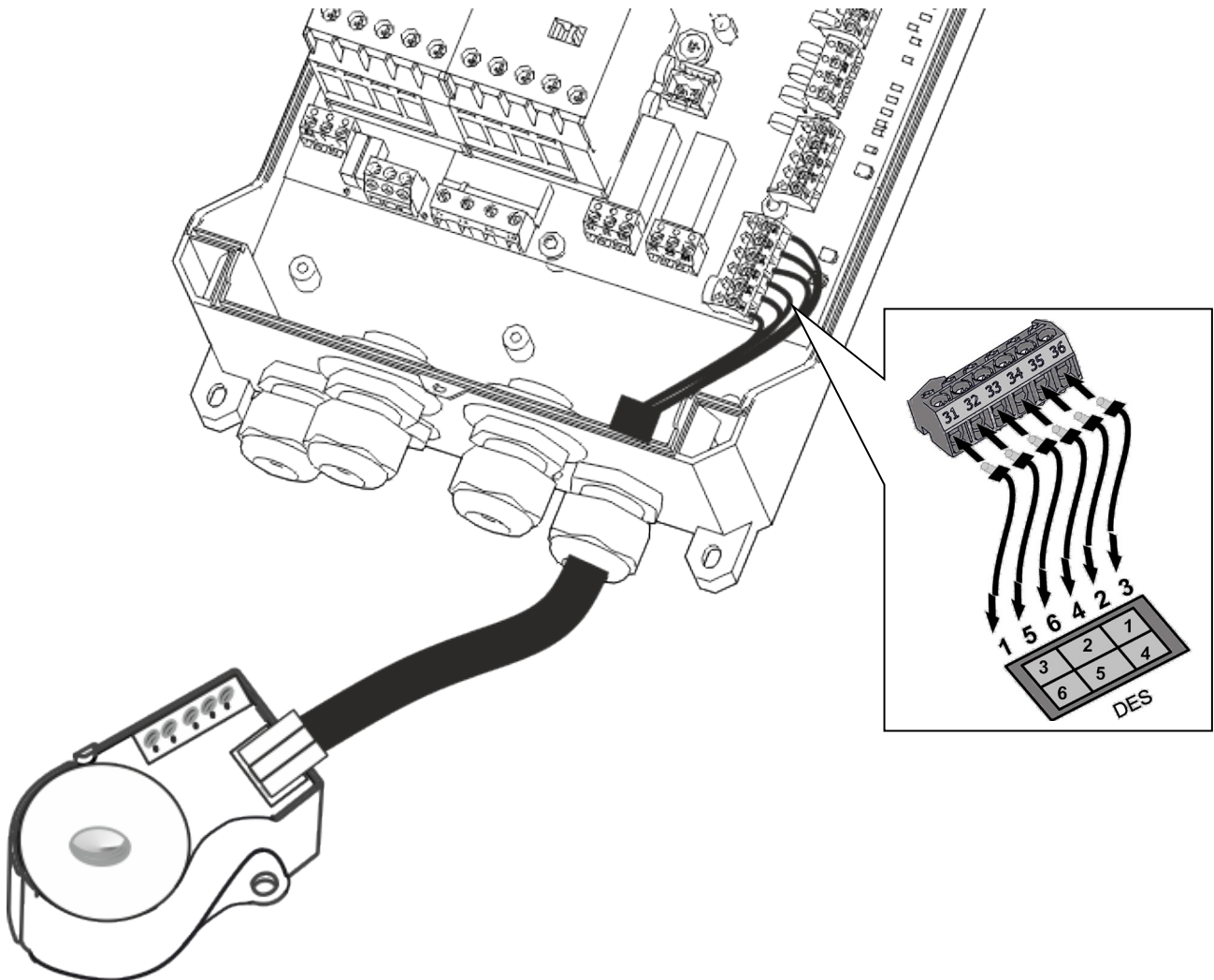

Figure 23: Connection of absolute encoder DES

Connection	Wire Assignment	
Absolute encoder DES	1	Emergency stop chain 1
	2	Channel B
	3	GND
	4	Channel A
	5	Emergency stop chain 2
	6	12 VDC

6.9.4 Mechanical limit switches

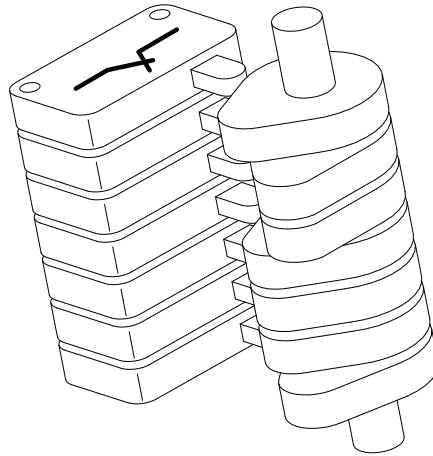

Figure 24: Cam switch

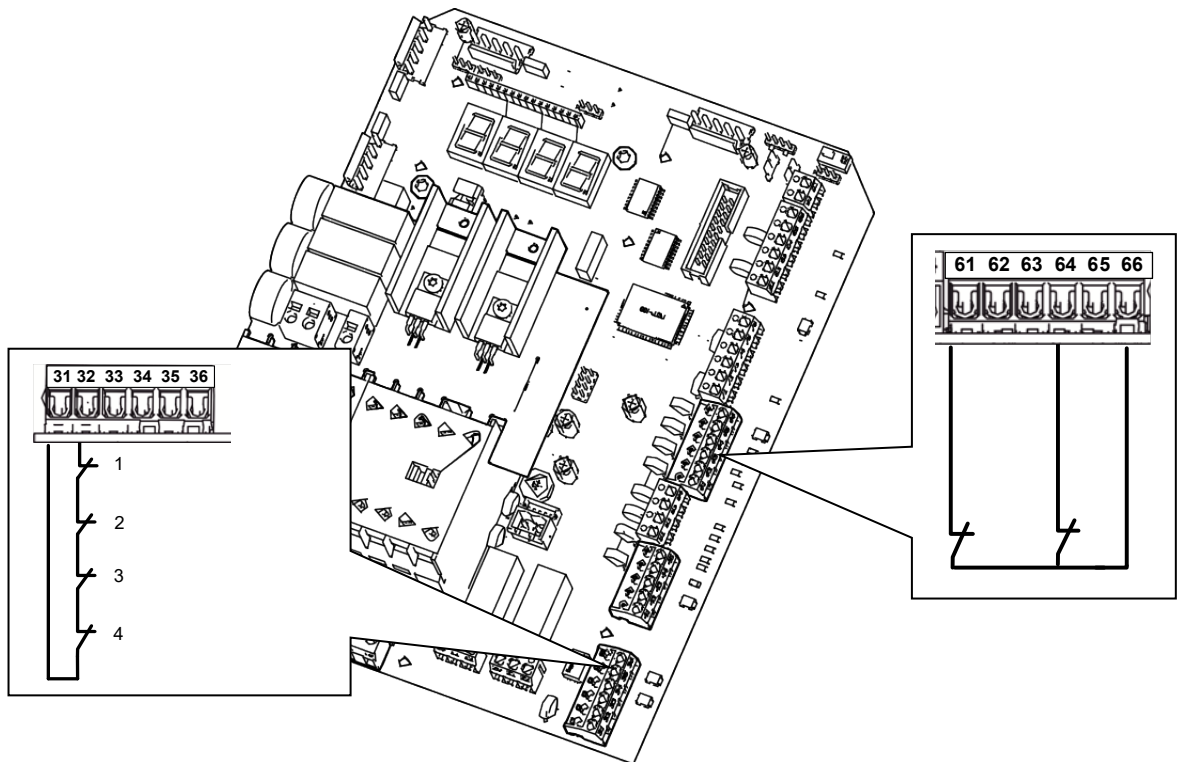

Figure 25: Connecting cam switches

Block	Terminal no. /Pin Assignment
X20	31 Emergency stop circuit
	1: Crank switch
	2: Thermo switch
	32 3: Emergency limit switch OPEN 4: Emergency limit switch CLOSE

Block	Terminal no. /Pin Assignment
X24	61 limit switch open
	64 limit switch close
	66 +24 V

6.10 Light beam

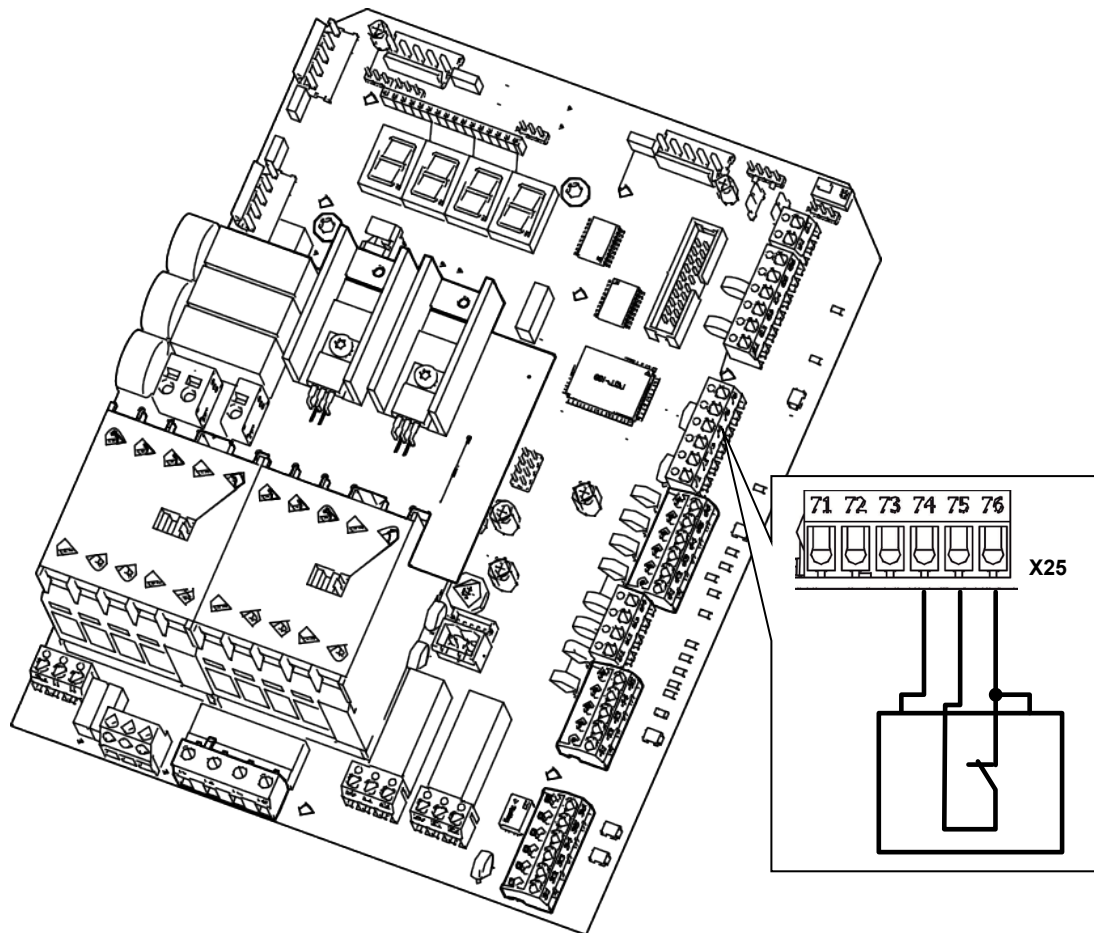

Figure 26: Photo eye connection

Block	Terminal no. /Pin Assignment	
X25	74	GND
	75	Input 5 light barrier
	76	+24 V

6.10.1 External triggering devices

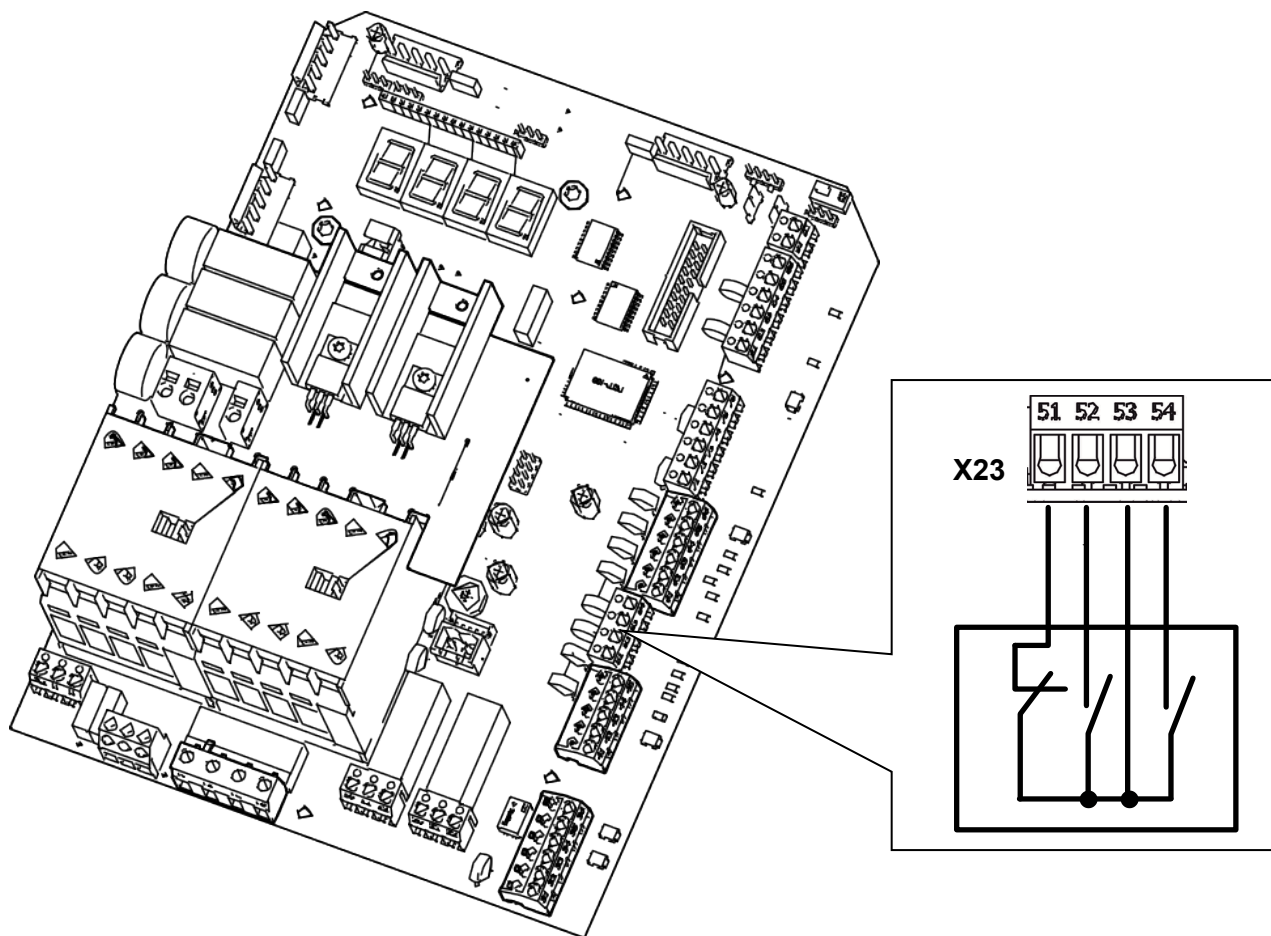

Figure 27: External triggering devices

Block	Terminal no. /Pin Assignment
X23	51 +24 V – stop
	52 OPEN – open
	53 STOP
	54 CLOSE – closed

6.10.2 Traffic light connection



Recheck all wiring connections before turning the controller on.
Incorrect connections may damage the unit.

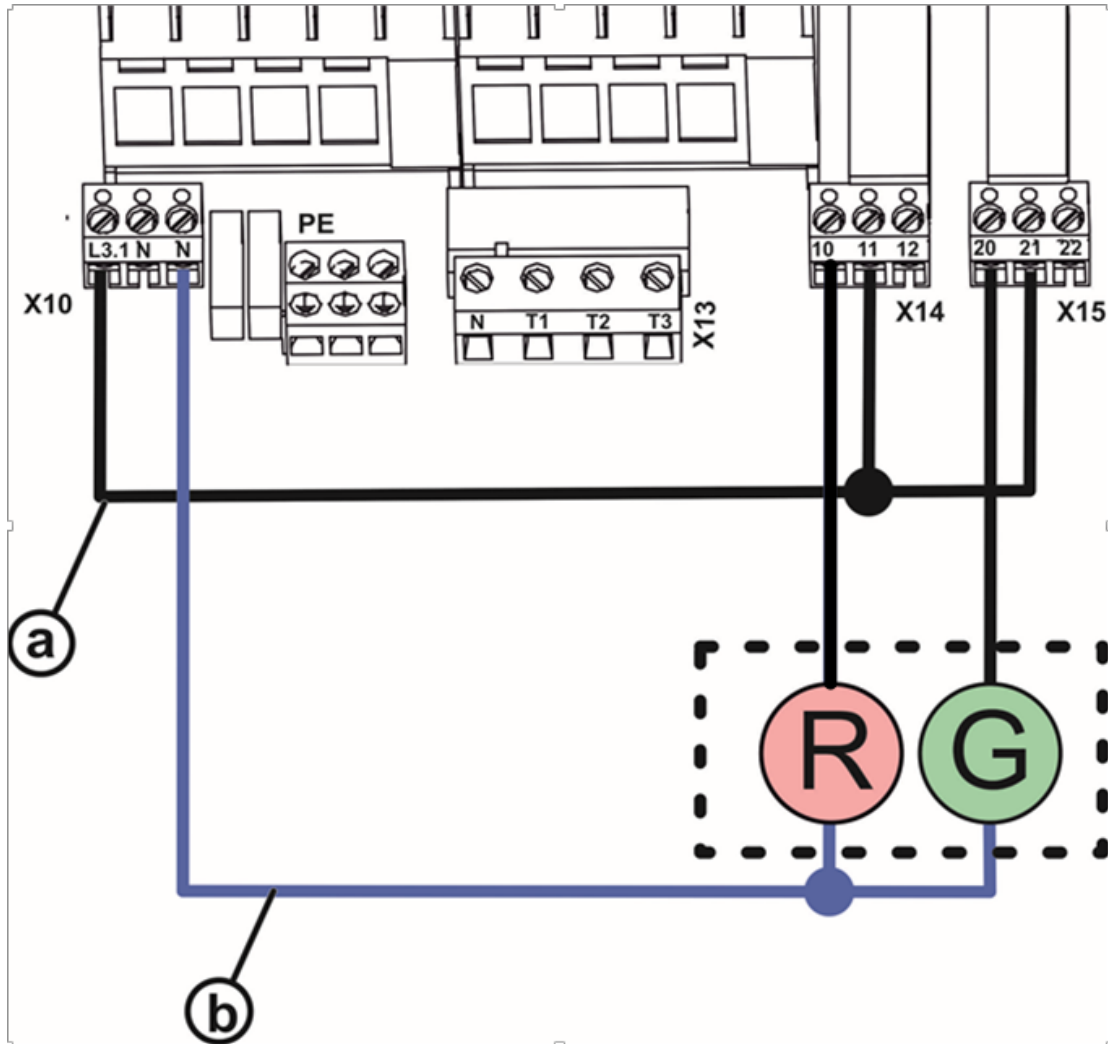



Figure 28: Traffic light connection

Pos.	Description
a	Jumper from "L" to "COM" of the output relays
b	"N" Connection of the traffic lights
R	Flashing red traffic light: flashing during door travel and during clearance time (P.701= 1253)
G	Green traffic light, stable Relay active in position "door OPEN" (P.702= 1210)



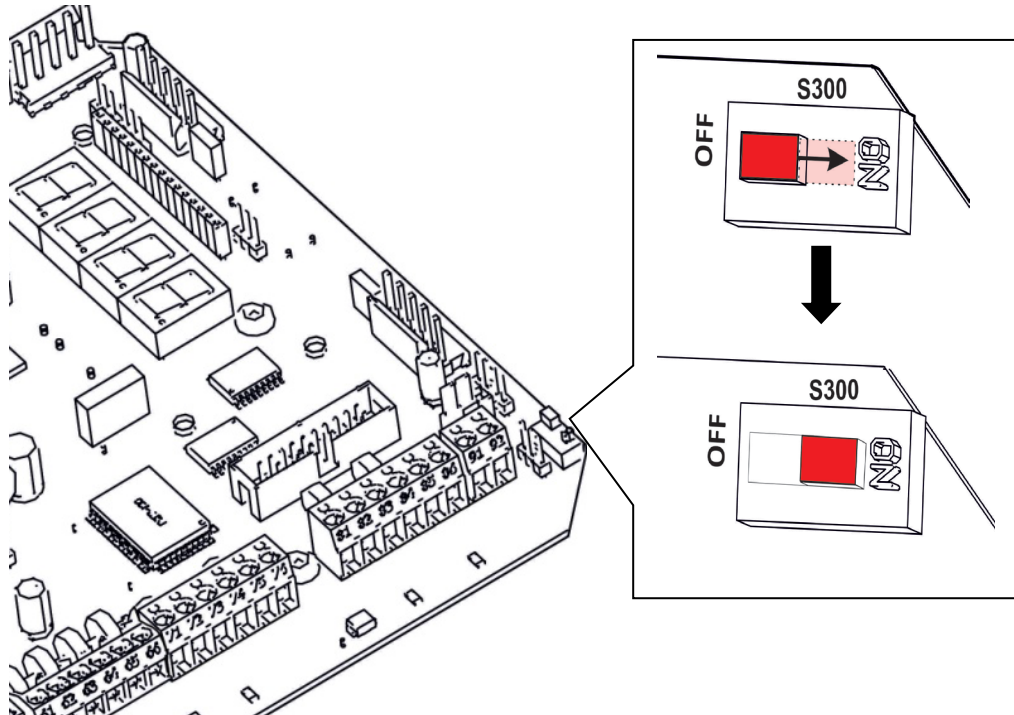

7 General operating instructions to set parameters

7.1 Open the parameter operation mode



1.  Turn off the door controller and wait until the display has been completely extinguished.
2.  Open the cover of the enclosure and switch the DIP switch S300 (see illustration) to ON. The service mode is activated and you can close the cover.

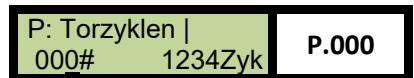

The service mode is automatically reset after approx. 1 hour. In order to reach service mode again, the controller must be turned off for a short period and then turned on again or a reset must be performed.

3.  Close the cover of the enclosure and turn on the controller.
4.  keep these pressed simultaneously to reach the parameter selection. (either appears 1: Clear text display or 2: 7-segment-display).





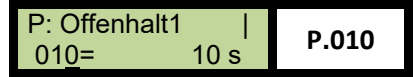



5.  Use the arrow keys to select the required parameter.
 or
 Not all the parameters are visible or may be changed immediately; this always depends on the password and the type of position set.



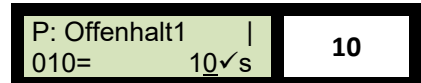
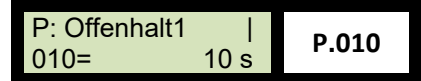

7.2 Editing a selected parameter

1.  By briefly pressing the STOP key on the membrane keypad, the cursor moves to the right to the stored value (the parameter is opened) or the preset value is displayed.

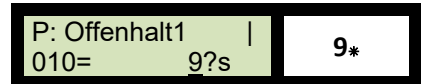

2.  The parameter value is increased with the OPEN button and reduced with the CLOSE button.
 or
  *If the value has not yet been saved, a question mark is displayed after the number or the decimal point flashes.*



3.  - If the STOP key is only pressed briefly, the set value is not saved and the value is changed to the originally stored value, i.e. the original value is displayed.

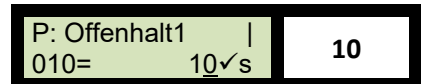

- If you keep the STOP key pressed until the check mark is displayed or the decimal point no longer flashes, the changed value is saved.

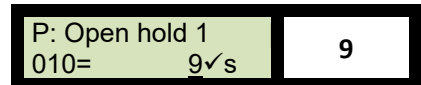

4.  If you now press the STOP key briefly, you change to the display of the parameter name or the cursor jumps back to the parameterization.

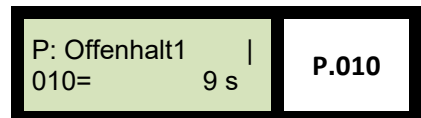

7.3 Exit parameter operation mode

-  Keep the STOP button pressed for approx. 3 seconds in order to leave the parameter mode and change to the door mode. The door operation is active when the display shows for example:

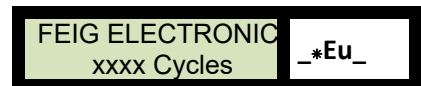

7.4 Execute a reset

-  +  +  press simultaneously for approx. 3. hold for seconds.

7.5 Entry into the extended parameter configuration mode

In order to reach the extended parametrization mode, a password must be entered in advance. The following parameter must be set for this:

P: Password 999= 0001 #	P.999
---------------------------------	-------

P.999 = 2 (extended commissioning mode)

P: Password 999= 0001✓#	0001
---------------------------------	------

P: Password 999= 0002?#	0*0*0*2*
---------------------------------	----------

P: Password 999= 0002✓#	P.999
---------------------------------	-------

8 Basic settings

To put the controller into operation, please follow the steps outlined in these instructions.

8.1 Automatic query of basic data

If the controller is not already preconfigured by the door manufacturer, the following parameters are queried automatically:



The DIP switch must have been turned on so that the controller can query parameters automatically.

If DIP switch is not turned on and the basic parameters not set, error code F.090 is displayed.



The controller uses indicator "-1" or "-" in the display as a flag that the acquisition of this parameter must be queried.

The basic data does not require changes when they were previously retrieved and set automatically. See chapter 7 (General operating instructions to set parameters)

For operating the controller, see chapter

. 7 "General operating instructions to set parameters"

- **Positioning system P.205** The limit switch system in use must be set using Parameter P.205.

P.205: 0 = Mechanical limit switches

P.205: 1 = Mechanical limit switches

P.205: 3 = Absolute encoder DES-A (GfA)

P.205 7 = Absolute encoder DES-B (Kostal)

P.205: 8 = Absolute encoder TST PD



The automatic query of basic data can be interrupted by pressing the  OPEN button when the controller is being turned ON. This causes a direct jump to the parameter configuration mode.

9 Startup...



Before starting the controller, check the electrical connections and the correct installation of the plug-in cards.

After start up, the operation of all the safety devices must be checked.



The settings are performed in dead man mode, i.e. press and hold the corresponding arrow key in the corresponding direction until the desired position is reached.

9.1 ... with absolute encoder

Open CALIBRATE mode by briefly pressing the  STOP key.





Move the door to the CLOSE position with the membrane keypad  CLOSE and

save by pressing the  STOP key for approx. 3 seconds.

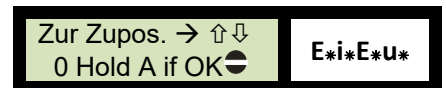

If the door moves in the incorrect direction: incorrect motor rotary field, turn off controller and reverse the 2 motor connections.



Move the door to the OPEN position by pressing the  OPEN key and press the  STOP key for approx. 3 seconds.

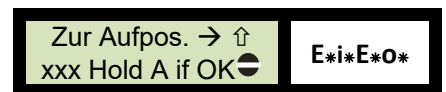

By the following movement of the door in automatic mode the pre-limit switches are set automatically.

6. Press  briefly, the door moves down and is now taught in its position.



7. Now press , repeat the process until the correction travel has been completed. (Anzeige I.510 = OK)

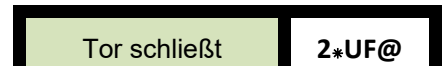
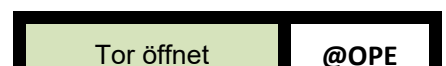
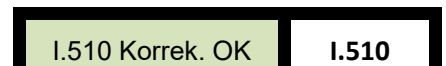
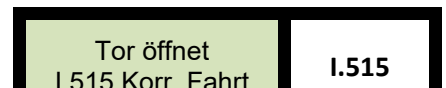
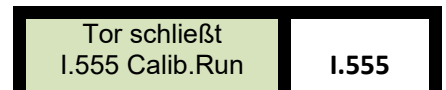

If the automatic limit switch correction was activated by means of P.216, the limit switch tapes are automatically calibrated by the next move of the door in automatic mode.

9.1.1 Renewed request for "learning" limit positions

If the limit positions have been pre-taught when using electronic limit switches, but these are not suitable for the respective door, the learning process for limit positions can be requested again.

The following parameter must be set for this:

P.210: 5 = Renewed teaching of all limit positions

9.2 ... with mechanical limit switches

1. Press the CLOSE-key  to move the door to a distance of approx. 10 cm from the closed position



If the door moves in the incorrect direction: incorrect motor rotary field, turn off controller and reverse the 2 motor connections.

2. Set lower limit switch so that it just trips



Do not travel past the limit switch at the limit positions!



3. Press OPEN-key  to move the door to approx. 10 cm from the opened position.

4. Set upper limit switch so that it just trips



Do not travel past the limit switch at the limit positions!

5. If required by the door type: adjust upper and lower EMERGENCY limit switches.
Connect the NC contacts, e.g. the safety circuit, in series with thermo pill.

6. Press  STOP and  OPEN key to enter parametrization mode and select Parameter P.980 "Service Mode", open and set parameter value "2" to "0" (Automatic mode).

7. Correct limit switch positions for door OPEN and door CLOSE as needed by fine adjustment of the limit positions in automatic mode. ** WARNING**

To prevent the door from moving unintentionally, adjust the limit switches only when the Emergency-STOP is activated or with the controller turned off!

8. The door may now be operated in automatic mode.

9.3 ... with light curtain TST LGB

Activating the TST LGB application

The application automatically sets several of the necessary function dependent parameters.

1. **Set application parameter A.480:** to "1".
2. **Automatic range query:** Set the real light curtain distance per parameter P.44A in steps of 0.5m.

 **The range must be set to correspond to the door width**

 **Open door completely!**
If the light curtain is occupied, the adjoining error message is displayed and the teach-in of all limit positions must be restarted.

Zur Aufpos. → Hindernis T75	E*1*0*5*
--------------------------------	----------

3. Open CALIBRATE mode by briefly pressing the  STOP key.

! Synchron. ! I615 LL angef.	I*615 SYNC:
---------------------------------	----------------

4. Open the door completely by pressing the  OPEN-key.

5. Save by pressing the  STOP-key for approx. 3 seconds.

Zur Aufpos. → xxx Übern. mit	S*Y*E*o* E*05o*
Zur Aufpos. → Folie Stop	SYNC E*05o*
Zur Aufpos. → 0 Übernahme mit	S*Y*E*o*
Zur Aufpos. → Folie Stop	S*Y*E*o*
LGx Qual. Test	S*Y*E*o*

 **If the door moves in the incorrect direction: incorrect motor rotary field, turn off controller and reverse the 2 motor connections.**

Light line alignment is being requested.

 **The detection zone of the light curtain must remain free otherwise the correction drive will be terminated and the synchronisation of the light curtain starts from the beginning.**

7. Start automatic teach-in of CLOSE-position by pressing the  CLOSE-key.

! Synchron. ! 0 Start with	S*Y*E*u*
-------------------------------	----------

Tor schließt.

Suche Si-Leiste -xxx Auto Zu	S*Y*c*L*
---------------------------------	----------

Door was detected in CLOSE-position and the light beams where taught-in correctly.

 *The subsequent travelling of the gate in automatic mode adjusts the pre-limit switches and limit switch tapes automatically.*

!Korrekturfahrt! xxx Start mit	I.515
!Korrekturfahrt! I615 LL Abgl. ok	I.610
! Korrekturfahrt ! xxx Start mit	I.515

8. Start correction drive by pressing the  OPEN-key.

Door opens and is taught-in into the position.

Display in end position OPEN.

Tor öffnet I.555 Lern Fahrt	I.555
Offenh= xxs I.515 Korr. Fahrt	I.515

The door closes automatically after the end of the auto-close time and then opens and closes independently so long until the correction movement has been completed.

Tor schließt I.515 Korr. Fahrt	I.515
Offenhalt = xxs I515 Korr. Drive	I.515

Display that correction was completed.

Offenh 1 = xxs I.510 Korr. OK	T.5
Offenh 1 = xxs Automatik	T.5

Tor öffnet

Optional display during a subsequent correction.

Tor öffnet	I.515 AUF`
Offenh 1 = xxs I 100 Auf Geschw.	I.100
Offenh 1 = xx s	T10
Tor schließt	2*UF@
FEIG ELECTRONIC xxxx Cycles	_EU_

Door closes and remains in its CLOSE position.

The commissioning of the light curtain has been successfully completed.

i Usually the lower limit position has to be corrected afterwards. This can be defined using the following parameters:

- **P.221:** Correction value end position door CLOSE -> this parameter must be reset after every new teach-in of all end positions (P.210=5).
- **P.275:** Correction of increments after conclusion of the synchronization -> recommended as fine setting for the end position BELOW. The value set here must NOT be re-set after the new teach-in of all end positions.

10 Functions

You will find an overview of Parameters of this assembly instruction and there description in the added document "Parameter list TST FUZZ"

11 Error messages

Faults can be acknowledged provided they are not reset automatically.



ACHTUNG The cause of the fault must be resolved first before the corresponding message is acknowledged.

Press the STOP button and keep it pressed, then press the EMERGENCY STOP button.

Alternatively, the STOP button can also be kept pressed for approx. 5 seconds.

No.	Description	Possible reason for error
F.000	Door position too far up	<ul style="list-style-type: none"> • Too small a parameter value for upper emergency limit switch → increase P.239 • Upper limit switch range (limit switch band) too small → increase P.233 • Mechanical brake defective or improperly set
F.005	Outside door position too far down	<ul style="list-style-type: none"> • Too small a parameter value for lower emergency limit switch → increase P. 229 • Lower limit switch range (limit switch band) too small → increase P. 223 • Mechanical brake defective or improperly set
F.010	Foil keypad short circuit	Foil key Open or CLOSE has a short circuit
F.020	Run time exceeded (during opening, closing or deadman)	<ul style="list-style-type: none"> • current motor run time has exceeded set maximum run time (P.410 (Opening), P.415 (Closing), P.419 (Deadman move)), door may be sticking or is blocked. • Door is blocked • If using mechanical limit switches, one may not have tripped
F.021	Emergency opening wrong testing	<ul style="list-style-type: none"> • The max. allowed run time (P.490) during testing has exceeded • Call service hotline
F.030	Lag error (position change of the door is less than expected)	<ul style="list-style-type: none"> • door or motor is blocked • insufficient power for providing necessary torque • too little speed • mechanical limit switch was not left or is defective • Incremental or absolute encoder shaft is slipping • wrong positioning system selected (P.205) • one motor phase is missing • the brake does not release • Settings of the failure detecting time are not correct (P.430 or P.450)
F.031	Detected rotational direction deviates from expected	<ul style="list-style-type: none"> • When using incremental encoders: Channel A and B reversed • Motor rotation direction reversed compared with calibration setting → teach in the limits new (P.210 = 5) • Too much „pancaking“ when starting, brake releases too soon, or too little torque, adjust boost (P.140 or P.145) as necessary.
F.033	Bad position transmitter protocol	<ul style="list-style-type: none"> • Fault on the bus of the position transmitter • No position data available over an extended period

No.	Description	Possible reason for error
F.043	Pre-limit switch fault (light barrier)	<ul style="list-style-type: none"> The pre-limit switch for the light barrier remains activated even in the middle end position or upper end position.
F.060	Breakaway recognized	<ul style="list-style-type: none"> Breakaway was detected but not fixed The automatic lead in after breakaway has failed
F.061	Belt breakage	An input configured as belt breakage sensor (P.50x = 0416) was activated. As long as the display flashes quickly, movements are not permitted -> acknowledgement required. Brief foil keyboard stop permits deadman moves. When the belt break was repaired mechanically and the input is no longer active an automatic acknowledgement is issued when the deadman closing movement reaches the closed.
F.080	Maintenance is required	<ul style="list-style-type: none"> Service counter has expired
F.090	Controller not parameterized	<ul style="list-style-type: none"> The min. necessary basic parameters for the controller have not yet been set → Activate DIP-switch and put in the asked parameters.
F.201	Internal E-Stop „push-button“ tripped or Watchdog (computer monitor) (watchdog only for FUS, FUN, FUE, FU3E, FU3P)	<ul style="list-style-type: none"> E-Stop chain was interrupted starting at input „internal E-Stop“ without parameterizing mode having been selected Internal parameter or EEPROM checks defective, pressing the STOP button provides additional information about the cause (only valid for FUS, FUN, FUE, FU3E, FU3P)
F.211	External E-Stop 1 tripped	<ul style="list-style-type: none"> E-Stop chain was interrupted starting at Input 1
F.212	External E-Stop 2 tripped	<ul style="list-style-type: none"> E-Stop chain was interrupted starting at Input 2
F.360	Short circuit detected on edge input	<ul style="list-style-type: none"> Short circuit detected on edges with normally closed contact The light beam of the optical edge is interrupted Jumper for 1K2 / 8K2 is wrong set
F.361	Number of trips of the Safety input D, normally this is the integrated safety edge evaluation, has reached set limit (configurable in P.46E)	<ul style="list-style-type: none"> Parameterized, maximum number of trips of the safety input D during a door cycle was exceeded → To reset close the door in deadman mode Check the set number of trips in P.46E
F.362	Redundancy error with short circuit	<ul style="list-style-type: none"> One of the processing channels for short circuit detection does not react identically with the second channel → Controller board defective, if no other error message F.3xx is shown Dynamical optical safety edge connected but not set in Parameter P.460
F.363	Interruption on edge input	<ul style="list-style-type: none"> Connection cable defective or not connected Termination resistor incorrect or missing Jumper 1K2 / 8K2 incorrectly set
F.364	Safety edge – testing failed	<ul style="list-style-type: none"> Safety edge was not activated as expected when requesting a test. The time between request for testing and actual testing not in agreement The pre-limit switch is set incorrectly

No.	Description	Possible reason for error
F.366	Too high a pulse frequency for optical safety edge	<ul style="list-style-type: none"> Defective optical safety edge Defective input for internal safety edge
F.369	Internal safety edge incorrectly parameterized	<ul style="list-style-type: none"> An internal safety edge is connected but deactivated → set P.460 to the used edge type
F.36A	Redundancy error of the 8K2 slip door switch on the internal safety edge evaluation unit	<ul style="list-style-type: none"> One of the contacts of the redundant 8k2 slip door switch is defective The slip door was not fully opened or closed
F.371	Number of trips of the Safety input E, normally this is the integrated safety edge evaluation, has reached set limit (configurable in P.47E)	<ul style="list-style-type: none"> Parameterized, maximum number of trips of the safety input E during a door cycle was exceeded → To reset close the door in deadman mode Check the set number of trips in P.47E
F.372	Redundancy error with short circuit	<ul style="list-style-type: none"> One of the processing channels for short circuit detection does not react identically with the second channel. Controller board defective
F.373	Fault in the safety edge (message comes from module)	<ul style="list-style-type: none"> Cable break to safety edge, no edge connected, edge termination resistor incorrect or defective Jumper for termination resistor definition in wrong position. Safety edge processing selected with Parameter P.470, but module not plugged in or wrong module.
F.374	Safety edge – testing failed	<ul style="list-style-type: none"> Pre-limit switch for safety edge incorrectly set or defective Processing module defective Safety edge defective
F.379	Safety edge detection defective (coding pin or parameter setting)	<ul style="list-style-type: none"> No module plugged in but was reported as present by a parameter The controller was started up with another module than the one currently plugged in
F.37A	Redundancy error of the 8K2 slip door switch on the internal safety edge evaluation unit channel 1	<ul style="list-style-type: none"> One of the contacts of the redundant 8k2 slip door switch is defective The slip door was not fully opened or closed
F.383	Interruption on safety input	<ul style="list-style-type: none"> Connection cable defective or not connected Termination resistor incorrect or missing Jumper incorrectly set
F.384	Safety input testing failed	<ul style="list-style-type: none"> Safety edge was not activated as expected when requesting a test. The time between request for testing and actual testing not in agreement
F.385	Fault in pre-limit switch for safety edge	<ul style="list-style-type: none"> Pre-limit switch for turning off the safety edge or reversing after safety edge tripping remains tripped even in the upper end position.
F.386	Too high a pulse frequency for optical safety edge	<ul style="list-style-type: none"> Faulty optical safety edge □ Defective input for internal safety edge
F.389	Safety input incorrectly parametrized	<ul style="list-style-type: none"> A safety edge is connected but deactivated Safety input Jumper incorrectly set (as digital input jumpered but as safety edge set)

No.	Description	Possible reason for error
F.38A	Redundancy error of the 8K2 slip door switch on the second internal safety edge evaluation unit	<ul style="list-style-type: none">• One of the contacts of the redundant 8k2 slip door switch is defective• The slip door was not fully opened or closed
F.3A1	Number of trips for safety input A has reached set limit	<ul style="list-style-type: none">• Parameterized, maximum number of safety input trips during a door cycle was exceeded
F.3B1	Number of trips for safety input B has reached set limit	<ul style="list-style-type: none">• Parameterized, maximum number of safety input trips during a door cycle was exceeded
F.3C1	Number of trips for safety input C has reached set limit	<ul style="list-style-type: none">• Parameterized, maximum number of safety input trips during a door cycle was exceeded

No.	Description	Possible reason for error
F.400	Controller hardware reset detected	<ul style="list-style-type: none"> • Excessive noise on supply voltage • Internal watchdog tripped • RAM error
F.401	Watchdog Error	<ul style="list-style-type: none"> • Internal Watchdog has released
F.40A	Software Exception	<ul style="list-style-type: none"> • internal error detected • internal Watchdog has released
F.410	Over-current (motor current or DC-bus)	<ul style="list-style-type: none"> • Wrong motor data set (P.100 – P.103) • Non-adjusted voltage increase / boost set (P.140 or P.145) • Motor not properly dimensioned for door • Door sticks
F.420	Overvoltage in DC-bus Limit 1	<ul style="list-style-type: none"> • Brake chopper interference / defective / missing • Feed voltage much to high • Motor is generating excessive voltage - brake chopper cannot dissipate the re-generated energy.
F.425	Overvoltage line supply	<ul style="list-style-type: none"> • The supply voltage for the controller is to high
F.426	Undervoltage line supply	<ul style="list-style-type: none"> • The supply voltage for the controller is to low
F.430	Temperature heat sink outside of working range Limit 1	<ul style="list-style-type: none"> • Excessive load on power stage or brake chopper • Ambient temperature too low for controller operation • Clock frequency of power stage too high (Parameter P.160)
F.440	Overcurrent in DC-bus Limit 1	<ul style="list-style-type: none"> • Boost not adjusted • Motor incorrectly dimensioned for door • Door sticks
F.510	Motor / DC-bus over current Limit 2	<ul style="list-style-type: none"> • Wrong motor data set (P.100–P.103) • Non-adjusted voltage increase / boost set (P.140 or P.145) • Motor not properly dimensioned for door • Door sticks
F.515	Motor protection function detected over current	<ul style="list-style-type: none"> • Incorrect motor curve (motor rated current) set (P.101) • Too much boost (P.140 or P.145) • Motor incorrectly dimensioned
F.519	IGBT driver chip detected over current	<ul style="list-style-type: none"> • Short circuit or ground fault on motor terminals • Motor rated current setting extremely wrong (P.100) • Extremely too much boost (P.140 or P.145) • Motor incorrectly dimensioned • Motor winding defective • Momentary interruption of the E-Stop circuit.

No.	Description	Possible reason for error
F.520	Overvoltage in DC-bus Limit 2	<ul style="list-style-type: none"> • Brake chopper interference / defective / missing • Incoming mains voltage much too high • Motor is generating excessive voltage - brake chopper cannot dissipate the re-generated energy
F.521	Low voltage in DC-bus	<ul style="list-style-type: none"> • Input voltage supply too low, usually at load • Load too great / final stage or brake chopper fault
F.522	Permissible DC current for a single-phase power supply is too high	On the FU3F a single-phase power supply was detected and the permissible DC current for a single-phase power supply is too high. This error always occurs in combination with F.540
F.524	ext. 24 V supply missing or too low	<ul style="list-style-type: none"> • Overload but no short circuit • When 24V is shorted the controller voltage does not ramp up and glow lamp V306 comes on.
F.525	Overvoltage at the incoming mains supply	<ul style="list-style-type: none"> • The incoming mains supply for the Controller is too high • The incoming mains supply fluctuates very extremely
F.530	Heatsink temperature outside of working range Limit 2	<ul style="list-style-type: none"> • Excessive load on final stages or brake chopper • Ambient temperature too low for controller operation • Clock frequency of final stage too high (Parameter P.160)
F.540	Overcurrent in DC-bus Limit 2	<ul style="list-style-type: none"> • Boost not adjusted • Motor incorrectly dimensioned for door • Door sticks
F.601	Bad light curtain reception quality	<p>Poor reception quality when the light curtain is started</p> <ul style="list-style-type: none"> • Light curtain dirty • Protection foil not removed • bad aligned • wrong Range set
F.610	Light curtain light line alignment	<p>Light line alignment has not been done</p> <ul style="list-style-type: none"> • Too less increments
F.611	Light curtain light line position values not plausible	<p>Position values stored by the light curtain do not match door movement</p> <ul style="list-style-type: none"> • Objects in the door area during teach in
F.612	External RS-485	<p>RS-485 communication failure between Receiver and Door Controller</p> <ul style="list-style-type: none"> • Insufficient valid position data • A and B wires twisted • wrong connection.
F.613	Internal RS-485	<p>RS-485 communication error between Transmitter and Receiver</p> <ul style="list-style-type: none"> • A and B wires twisted • wrong connection

No.	Description	Possible reason for error
F.615	Internal error light curtain transmitter	Internal error transmitter - RAM test fail - ROM test fail - Program run error - Sync error - Address module defective - dark test fail - DA converter defective - exchange hardware!
F.616	Internal error light curtain receiver	Internal error receiver: - RAM test fail - ROM test fail - Program run error - Sync error - Address module defective - dark test fail - DA converter defective - Watchdog not triggered or hangs - exchange hardware!
F.617	Light curtain incompatibility	Transmitter and receiver are not compatible. • modified Transmitter serial number • incompatible Hardware version / revision level • incompatible Software version
F.621	Light curtain test error (transmitter)	test error for the internal transmitter system test
F.622	Light curtain test error (receiver)	test error for the internal receiver system test
F.626	Light curtain test error (Out 1)	Test / wiring error of output 1
F.627	Light curtain test error (Out 2)	Test / wiring error of output 2
F.628	Light curtain dark test error	Dark test error: <input type="checkbox"/> external light source <input type="checkbox"/> uncontrolled transmissions <input type="checkbox"/> defective receiver

No.	Description	Possible reason for error
F.700	Position sensing defective	<p>With mechanical limit switches:</p> <ul style="list-style-type: none"> • At least one limit switch does not correspond to the configured active status. • An implausible combination of at least 2 active limit switches. <p>For electronic limit switches:</p> <ul style="list-style-type: none"> • After invoking activation of the factory parameters (Parameter P.990) the corresponding positioning system was not parameterized. • Calibration not completed or is incorrect and must be repeated. • When activating the intermediate stop the intermediate stop is implausible. • Synchronization not finished or reference switch defective.
F.752	Loss of communication with encoder	<ul style="list-style-type: none"> • Interface cable defective / interrupted • supply voltage 12 Volt faulty, e.g. shortcut in spiral cable • Channel A and B connected over cross • Absolute encoder processor electronics defective • Defective hardware or electrically noisy environment • Use a shielded control cable • Install a RC element (100Ω+100nF) at the brake
F.760	Position outside of window	<ul style="list-style-type: none"> • Position encoder drive defective • Absolute encoder processing electronics defective • Defective hardware or electrically noisy environment
F.763	DES-B Error	<ul style="list-style-type: none"> • Position encoder drive defective -> make a reset
F.766	Internal error TST PD/PE	<ul style="list-style-type: none"> • The position encoder TST PD / PE is disturbed -> make a reset
F.767	Overtemperature TST PD	<ul style="list-style-type: none"> • The temperature in the encoder housing is too high
F.768	Battery voltage	<ul style="list-style-type: none"> • The voltage of the buffer battery is too low → change battery
F.769	Rotation speed of PD shaft too high	<ul style="list-style-type: none"> • The rotation speed of the shaft where the encoder is mounted is too high → mount the encoder on another shaft
F.770	Door way is too high for the parameter set Encoder resolution	<ul style="list-style-type: none"> • The Value of the Parameter P.202 (set Encoder resolution) is too high for the combination encoder and door.
F.801	Wrong Test of input 1 of the mobile unit TST FSx	<ul style="list-style-type: none"> • Input 1 of the mobile unit was tested wrong • The device which is connected to the input does not work correctly • The mobile unit is defective
F.802	Wrong Test of input 2 of the mobile unit TST FSx	<ul style="list-style-type: none"> • Input 2 of the mobile unit was tested wrong • The device which is connected to the input does not work correctly • The mobile unit is defective
F.803	Wrong Test of input 3 of the mobile unit TST FSx	<ul style="list-style-type: none"> • Input 3 of the mobile unit was tested wrong • The device which is connected to the input does not work correctly • The mobile unit is defective

No.	Description	Possible reason for error
F.804	Wrong Test of input 4 of the mobile unit TST FSx	<ul style="list-style-type: none"> • Input 4 of the mobile unit was tested wrong • The device which is connected to the input does not work correctly • The mobile unit is defective
F.80A	Wrong Test of input A of the stationary unit TST FSx	<ul style="list-style-type: none"> • Input A of the stationary unit was tested wrong • The device which is connected to the input does not work correct • The stationary unit is defective
F.80B	Wrong Test of input B of the stationary unit TST FSx	<ul style="list-style-type: none"> • Input B of the stationary unit was tested wrong • The device which is connected to the input does not work correct • The stationary unit is defective
F.80C	Wrong Test of input C of the stationary unit TST FSx	<ul style="list-style-type: none"> • Input C of the stationary unit was tested wrong • The device which is connected to the input does not work correct • The stationary unit is defective
F.811	Wrong test for output 1 of the stationary unit	<ul style="list-style-type: none"> • Output 1 of the stationary unit was tested incorrectly • The cable between the stationary unit and the controller is damaged or not connected • The stationary unit is defective • Incorrect settings for parameter P.5xF, P.47b or P.465
F.812	Wrong Test for output 2 of stationary unit TST FSx	<ul style="list-style-type: none"> • Output 2 of the stationary unit was tested incorrectly • The cable between stationary unit and controller is damaged or not connected • The stationary unit is defective • Incorrect settings for parameter P.5xF, P.47b or P.465
F.813	Wrong Test of output 3 of the stationary unit TST FSx	<ul style="list-style-type: none"> • Output 3 of the stationary unit was tested incorrectly • The cable between the stationary unit and the controller is damaged or not connected • The stationary unit is defective • Incorrect settings of parameter P.5xF, P.47b or P.465
F.821	Wrong parameter setting input 1 of mobile unit	<ul style="list-style-type: none"> • The device which is connected to input 1 of the mobile unit does not fit to the settings • Check Parameter P.F1F
F.822	Wrong parameter setting input 2 of mobile unit	<ul style="list-style-type: none"> • The device which is connected to input 2 of the mobile unit does not fit to the settings • Check Parameter P.F2F
F.823	Wrong parameter setting input 3 of mobile unit	<ul style="list-style-type: none"> • The device which is connected to input 3 of the mobile unit does not fit to the settings • Check Parameter P.F3F
F.824	Wrong parameter setting input 4 of mobile unit	<ul style="list-style-type: none"> • The device which is connected to input 4 of the mobile unit does not fit to the settings • Check Parameter P.F4F
F.831	Disturbed input 1 of mobile unit TST FSx	<ul style="list-style-type: none"> • The input 1 of the mobile unit is disturbed • The connection to the device is interrupted
F.832	Disturbed input 2 of mobile unit TST FSx	<ul style="list-style-type: none"> • The input 2 of the mobile unit is disturbed • The connection to the device is interrupted
F.833	Disturbed input 3 of mobile unit TST FSx	<ul style="list-style-type: none"> • The input 3 of the mobile unit is disturbed • The connection to the device is interrupted

No.	Description	Possible reason for error
F.834	Disturbed input 4 of mobile unit TST FSx	<ul style="list-style-type: none"> • The input 4 of the mobile unit is disturbed • The connection to the device is interrupted
F.841	Frequency error on input 1 of mobile unit	<ul style="list-style-type: none"> • The connected optical safety edge is faulty
F.843	Frequency error on input 3 of mobile unit	<ul style="list-style-type: none"> • The connected optical safety edge is faulty
F.851	Max. Number of allowed Reversings, because of bad WiCAB radio, exceeded.	The radio connection interrupts during door drive for a short time
F.852	Communication error between TST FSx and controller	<p>This error occurs when the controller loses RS485 communication for min. 1 second with the stationary unit of the radio strip TST FSx. Possible causes are:</p> <ul style="list-style-type: none"> • The stationary unit is broken • The stationary unit is not or wrong connected
F.853	TST PE_FSBS operating voltage too low	The operating voltage of encoder TST PE_FSBS is too low (less than 8V) As a result, the calculation of the position must be terminated.
F.856	Communication error between mobile and stationary unit	<p>This error occurs if the mobile unit and the stationary unit of the radio control unit could not establish radio communication for at least 1 second. Possible causes are:</p> <ul style="list-style-type: none"> • No mobile unit in radio range • The battery of the mobile unit is empty or not connected • The antenna of the stationary unit is not connected or missing • Mobile unit or stationary unit is defective
F.857	Battery empty	<ul style="list-style-type: none"> • The battery voltage is under the limit set with Parameter P.F0B • The battery voltage of the mobile unit is too low • Use new battery and set back battery capacity to 100% by pressing the stop key for long time in P.F09. • To deactivate this error message you can set P.F09 and P.F0B to 0
F.859	Software Version	The software versions of the stationary and the mobile unit are not compatible. No safe trip possible.
F.860	Internal fault stationary unit	Internal system fault on the stationary unit.
F.861	Internal fault mobile unit	Internal system fault on the mobile unit.
F.862	Internal positioning system error	Internal error of the positioning system. Presumably, the magnet is not attached properly.
F.867	Address of mobile unit not set	<ul style="list-style-type: none"> • The address of the mobile unit was not set so far • The address has to be set in Parameter P.F07 • The address is written on a sticker on the mobile unit
F.912	RAM error on extension board	<ul style="list-style-type: none"> • Defective hardware or noise-saturated environment
F.920	Internal 2.5 V reference voltage incorrect	<ul style="list-style-type: none"> • Hardware defect
F.921	Internal 15 V voltage incorrect	<ul style="list-style-type: none"> • Hardware defective
F.922	Static and dynamic monitoring	Static monitoring: Interrupted emergency stop chain means: All emergency inputs from the interrupted one,

No.	Description	Possible reason for error
	of the emergency stop chain against defect or external power (static monitoring is offered by each controller, dynamic monitoring does not exist in WU2/WU12/FUH/FU3R/FUZ/FUZ2)	including all subsequent emergency inputs, must be triggered, if one of the subsequent emergency inputs is not triggered it must be assumed that a remote supply is used Dynamic monitoring: During the system tests, the closed emergency chain is actively opened by an internal switch, so that all emergency inputs must be activated, if this does not occur, it must be assumed that an external supply is used or that a defect has occurred
F.928	Faulty input testing	<ul style="list-style-type: none"> • The testing of an cyclic tested input was not successful • The connected device is not working • The cable connection between the connected device and the controller is broken
F.929	Faulty K-stop relay	<ul style="list-style-type: none"> • The testing of the stop relay was not successful • Controller defective
F.930	External watchdog incorrect	<ul style="list-style-type: none"> • Defective hardware or noise-saturated environment
F.931	ROM error	<ul style="list-style-type: none"> • Wrong EPROM code • Defective hardware or noise-saturated environment
F.932	RAM error	<ul style="list-style-type: none"> • Defective hardware or noise-saturated environment
F.933	Wrong frequency of CPU	<ul style="list-style-type: none"> • The clock frequency of the processor is wrong
F.935	Stack error	User-Stack or System-Stack overflowed Possible software error due to recursive invocations (e.g. profile)
F.939	Triac extender readback signal is wrong	<ul style="list-style-type: none"> • Signal cable is not connected or defective • Hardware of the triac extender is defective
F.941	ROM Error of I/O Processor	<ul style="list-style-type: none"> • ROM Error of I/O Processor
F.960	Faulty parameter checksum	<ul style="list-style-type: none"> • New EPROM version with different parameters • Controller not yet initialized
F.961	Checksum from calibration values etc.	<ul style="list-style-type: none"> • new EPROM version with changed EEPROM structure • control not yet initialized
F.962	Converter parameters not plausible	<ul style="list-style-type: none"> • New EPROM version • Controller not yet initialized
F.964	Program version / manufacturer code	<ul style="list-style-type: none"> • New EPROM version • Controller not yet initialized
F.965	Faulty door cycle counter with active emergency opening	<ul style="list-style-type: none"> • The door cycle counter does not count or is faulty. Because of this no emergency opening testing can be done.
F.970	Plausibility parameter block error	<ul style="list-style-type: none"> • New EPROM version • Controller not yet initialized • Some parameter is implausible

12 Information messages

No.	Description
I.043	<ul style="list-style-type: none"> • During teaching there was passing traffic that triggered the photo eye. • The photo eye position tolerance set in P.4xA was exceeded or dropped below in two successive cases.
I.080	Service counter will run off
I.160	Permanent open command still active
I.161	Priority still active
I.170	Forced opening active
I.180	Wait for foil key command
I.185	Wait for reset by stop foil key
I.199	Door counter wrong
I.205	Synchronisation done
I.210	Limit switch not plausible
I.211	Limit switch not plausible
I.310	Open command to door 2
I.360	Disturbed N.C. safety edge
I.363	Disturbed N.O. safety edge
I.380	Faulty 2nd internal N.C. safety bar
I.383	Faulty 2nd internal N.O. safety bar
I.510	Correction drive finished
I.515	Active correction drive
I.520	Target speed for opening or closing move not reached <ul style="list-style-type: none"> • Pre-limit switch reached before full speed was reached --> adjust ramps • Current limiter prevents movement at full speed --> Inverter or motor working at performance limit --> adjust ramps or limiter
I.555	Measuring rotation factor not ready
I.610	Light line alignment completed successfully.
I.615	Light line alignment requested.
I.616	Second light line alignment The second light line alignment with normal drive speed is active
I.621	Light curtain position encoder resolution too low The resolution of the installed position encoder is too low to maintain robust light curtain operation. More increments are required per door move. (Message only occurs when DIP-Switch is ON.)
I.856	The internal safety edge is tripped because of an WiCab radio problem The radio connection interrupts during door drive for a short time. Possible causes are: <ul style="list-style-type: none"> • The Distance between mobile and stationary unit is larger than specified • No perfect Orientation of stationary and mobile antenna • The radio link is disturbed by external noise

13 General messages

General messages	
STOP	Stop / Reset state, wait for next incoming command
Eu	Lower limit position Eu
≡Eu≡	Lower limit position locked → raising not possible (e.g., lock-door)
ZUF@	Closing active
-Eo-	Upper limit position Eo
≡Eo≡	Upper limit position locked → closing not possible (e.g., safety edge)
@OPE	Opening active
-E1-	middle limit position E1 (intermediate stop position)
≡E1≡	upper limit position locked → closing not possible (e.g., safety edge)
FAIL	Fault → only deadman travel is possible, automatic opening may also be possible
CALI	calibration → setting the limit positions in deadman travel mode (for absolute encoder) → Start procedure using STOP key
≡ES≡	E-stop → Travel not possible, hardware safety chain interrupted
HdSA	E-travel → Deadman travel without regard for safety facilities, etc.
'Hd'	Manual → Deadman mode
ParA	Parametrization
'Au'	Automatic → indicates change from "Manual" to "Automatic" status
'Hc'	Semi-automatic → indicates change from "Manual" to "Semi-automatic"
IP 2	first display after switching on (Power Up and Self-test)
Status messages during calibration	
E.i.E.c.	calibration of the lower limit position requested (in deadman travel)
E.i.E.o.	calibration of the upper limit position requested (in deadman travel)
E.i.E.1	calibration of intermediate position E1 (in deadman travel)
Status messages during dead man movement:	
Hd.cL	Deadman closing (membrane key: CLOSE)
Hd.oP	Deadman closing (membrane key: OPEN)
Hd.Eu	Lower limit position reached, no further deadman closing possible
Hd.Eo	Upper limit position reached, no further deadman opening possible
Hd.Ao	Outside of permitted Eo position (no deadman opening possible)
Information messages during the parameter configuration	
noEr	Error memory: no error saved
Er--	Error memory: if error but without associated message being found
Prog	Programming message while carrying out original parameter or default set

General inputs	
E.000	OPEN key on membrane keypad
E.050	STOP key on membrane keypad
E.090	CLOSE key on membrane keypad
E.101	Input 1
E.102	Input 2
E.103	Input 3
E.104	Input 4
E.105	Input 5
E.106	Input 6
E.107	Input 7
E.108	Input 8
E.109	Input 9
E.110	Input 10
E.121	Input 21
...	...
E.128	Input 28
E.131	Input 31 (only with TST SUVEK)
Safety- / emergency stop chain	
E.201	Internal E-Stop "mushroom button" tripped
E.211	External E-Stop 1 tripped
E.212	External E-Stop 2 tripped
Safety edge in general	
E.360	activation of internal safety edge (interruption)
E.363	activation of internal safety edge (short circuit)
E.380	Triggering of the 2nd internal safety edge
E.383	Interruption of the 2nd internal safety edge
Wireless plug-in module	
E.401	Radio Channel 1
E.402	Radio Channel 2
Inductive loop detection – plug-in module	
E.501	Detector channel 1
E.502	Detector channel 2

14 Specifications

Housing dimensions			
Dimensions board set (L x W x H):	approx. 270 x 195 x 150 mm to frame with quick release excl. extension boards as TST RWU		
Variant in small housing (W x H x D)	approx. 182 x 328 x 94 mm not for 4 kW version !		
Dimensions plastic housing (H x W x D)	approx. 430 x 210 x 200 mm incl. wall mounts excl. cable entries (L +20 mm) and main switch (H+ 35 mm)		
Dimension steel or stainless steel housing	approx. 300 x 476 x 218 mm approx. 400 x 676 x 218 mm approx. 600 x 676 x 218 mm excl. cable entries (L +20 mm) , main switch and emergency stop button (H+ 35 mm)		
Hygiene housing dimensions	approx. 444 x 549 x 210 mm excl. cable entries (L +20 mm) , main switch and emergency stop button (H+ 35 mm)		
Assembly:	vertical		
Power supply range for 3-phase current with N	3 x 200 ... 415 V $\pm 10\%$ / 50 .. 60 Hz corresponds to a power supply voltage of 115 ... 240 V $\pm 10\%$ / 50 .. 60 Hz		
Duty cycle 4 kW version:	60% at 50°C e.g. 36 s inactive and 24 s active		
Required fuses	3x 10 A Type K with 2.2 kW and 1.1 kW version 3x 16 A Type K with 4 kW version		
Power consumption power supply unit without motor	max. 30 W		
Power consumption power supply unit with motor AC3 Version TST WUE-A at	400 V max. 2.2 kW	230 V max. 1.5 kW	115 V max. 0.75 kW
Power consumption power supply unit with motor AC3 Version TST WUE-E at	400 V max. 4 kW	230 V max. 2.2 kW	115 V max. 1.1 kW
External power supply	phase L1 via fuse F200 (4 AT) on terminal L3.1		
Control voltage / external supply 2	24 V _{DC} / $\pm 5\%$ max. 500 mA including all plug-in modules and 12 V connections fused via self-resetting semiconductor fuse Protected by self-resetting semiconductor fuse.		
External supply 12 V	11.3 V _{DC} $\pm 5\%$, controlled, max. 150 mA		
Control inputs IN1 ... IN10	24 V _{DC} / typ. 15 mA min. Duration of input control commands: > 100 ms all inputs are potential free to join or: <2 V: inactive → logical 0 >17 V: inactive logical 1 →		
Input IN10	Evaluation for slip door switch with 8.2 k Ω termination resistor or is used as a second safety edge monitor.		
RS485 A and B	only for electronic limit switches RS485 level, terminated in 100 Ω		
Safety chain / emergency off	all inputs must be connect free of potential <15 V: inactive → logical 0 >17 V: inactive logical 1 → Contact rating: ≤ 26 V _{DC} / ≤ 120 mA in case the safety chain is interrupted, the drive cannot be moved, not even under Deadman conditions		
Safety edge input:	For electrical safety edges with 1.2 or 8.2 k Ω terminating resistor and for dynamic optical systems		
Relay outputs	If inductive loads are connected (for example, additional relays or brakes), these must be equipped with the appropriate suppression measures (freewheeling diode,		

	varistors, RC elements)!	
Relay K1 and K2	24 VDC / 500 mA ⇒ 230 VAC / min. 0.1 A / max. 80 W potential-free switching, change-over contact	Contacts used once for circuit breakers cannot switch further low currents.
Drive output	3x 400 VAC max. 2.2 kW at AC-3 with version TST WUE2-A max. 4 kW at AC-3 with version TST WUE2-E Reversing contactor is prepared for operating three-phase drives max. length of motor cable: 30 m	
Electromechanical brake	230 V _{AC} - control via switched motor phase and N	
Temperature operating range	-20...+50°C	
Temperature storage range	-20...+70°C	
Relative humidity	up to 95% non-condensing	
Connection type of the power line	Y, power cables must only be replaced by the manufacturer, authorized service agents or qualified persons	
Equipment mobility:	stationary	
Protection class:	Protection class I	
Equipment type:	Motor type external motor is not part of the delivery from FEIG ELECTRONIC GMBH	
Noise Emission	< 30dB(A)	
Vibration	low-vibration installation, e.g. on a concrete wall	
Protection class	IP54 (IP65 by replacing CEE connection and sealing cable entries). All unused cable entries must be closed.	
Protection class (board variant)	No (IP00)	
Type tested to:	Standards:	
Machinery Directive:	➔ Device complies with Annex IV categories of machinery – Section 21 "logic unit for safety functions"	
	<p>"EN ISO 13849-1:2015 Safety of machinery – safety-related parts of control systems –part 1: General design principles</p> <ul style="list-style-type: none"> • Category: 2 • Performance Level (PL): d • Safe functions: <ul style="list-style-type: none"> ○ Endpoint detection ○ Contacting edge evaluation (8,2/1,2 kΩ or optical) ○ Photo eye incl. pull-in protection (comp. EN 12453 table 1: type D or type E with test) ○ Personnel door switch ○ Slack rope switch <p>EN 62061 : 2005 Safety of machinery–Functional safety of safety-related electrical, electronic and programmable electronic control systems (IEC 62061:2005)</p> <ul style="list-style-type: none"> ○ Safety integrity levels (SIL): 1 	
Low-Voltage Directive: 2014/35/EU	<p>DIN EN 60335-1: 2012 / A11:2014 Safety of household and similar electrical appliances/ Part 1: General requirements</p> <ul style="list-style-type: none"> • Type: stationary motor-driven machines • Protection class I <p>EN 60335-2-103:2015 Safety of household and similar electrical appliances- - part 2-103: Special requirements for drives for industrial doors, doors and windows</p>	

EMC Directive: 2004/108/EC	<p>Electromagnetic compatibility – basic technical standards:</p> <p>EN 61000-6-1:2007 interference immunity, living area</p> <p>EN 61000-6-2:2006 / AC:2005 interference immunity, industrial area</p> <p>EN 61000-6-3:2007 / A1:2011 / AC:2012 Electromagnetic radiation, living area</p> <p>EN 61000-6-4:2007 / A1:2011 Electromagnetic radiation, industrial area</p>
Applied national specifications regarding the above directives:	<p>EN 12453:2000 Nutzungssicherheit kraftbetätigter Tore – Anforderungen</p> <ul style="list-style-type: none"> • Kapitel 5.2 Antriebssysteme und Energieversorgung <p>Nur TST WU2 / TST WUI2</p> <p>EN 12453:2017 Nutzungssicherheit kraftbetätigter Tore – Anforderungen</p> <ul style="list-style-type: none"> • Kapitel 5.2 Antriebssysteme und Energieversorgung <p>Nur TST WUE2 / TST WUIE2</p>