

GB

Assembly, connection and maintenance of the device may only be executed by personnel trained accordingly. At this the underlying national and local regulations have to be observed.

Cody Universal 3



Gerätebeschreibung



The Cody Universal 3 consists of a decoder and a control element. The units are connected by a simple two-wire cable without a special plug. Programming of the Cody Universal 3 is possible with the keypad and the master code.

The Cody Universal 3 gives you the possibility of direct control of an industrial door control. After entering a valid pass code, the user can use the STOP button and the arrow keys UP ▲ and DOWN ▼ to drive a motor in dead man.

The two relays are electrically interlocked, so it is not possible that both relays are activated simultaneously.

Mastercode:

The mastercode is an 8 digit numeral code necessary for all programming procedures.

Only after the input of this code the appliance can be programmed according to your personal needs. Cody Universal 3 is preset by the company with the master code 12345678.

Pass code:

The pass code is either a four or five digit numeral code, by which you operate your door drive unit. You have the possibility to store up to 50 different pass codes, which means that up to 50 different persons with individual pass codes can open the door. If you are accompanied by another person when entering your pass code you can first press as many keys as you like before you finally enter your code. This ensures that no other person can notice your pass code. The Cody Universal 2 is preset with the pass code 1234 on memory slot 00.

Note: Optional Cody Universal Service Tool

The Cody Universal Service Tool gives you the possibility to program your Cody Universal conveniently to your requirements. A LCD display shows you every programming step, including the # of a used memory slot, relays settings etc. It also allows you to delete transponders directly by their used memory slot.

Ref. 500.STU0.00



General reset



General reset

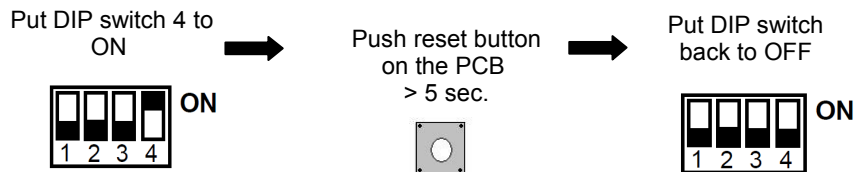

All factory settings are restored by the general reset !

Factory settings (default settings):

- all slots erased (except 00)
- mastercode = sequence 1-8
- pass code 00 = sequence 1-4
- Tiptomatic time = 60 sec.
- look-out time = 20 sec.

ATTENTION!!!

After you have made yourself familiar with the functions of the appliance, please program your personal mastercode as well as a pass code with which you replace the pass code which is located on the memory place 00. Only by this your Cody Universal 3 is protected against manipulation!

TIPTOMATIC:

The Cody Universal 3 has three potential free relay outputs enabling direct control of a industrial door control unit. After having entered a valid pass code the user can, within a period of 60 seconds, trigger the installed drive unit in the dead man's mode with the STOP button or the arrow keys UP ▲ and DOWN ▼ .

The relay is activated only as long as the arrow keys are pushed. The relays are interlocked against each other, so it is not possible that both relays can be switched at the same time. After expiration of the of 60 seconds the Cody Universal 3 locks automatically. This function, however, can be interrupted prior to the expiration of the 60 seconds, by pressing the  button.

Lock-out function:

If the lock-out function is activated, the Cody Universal 3 automatically blocks any input for a set period after the input of a wrong pass code which is signalled with a (3 beeps) sound signal. You can freely program the lock-out time according to your requirements.

The end of the lock-out time is signalled by a long sound signal.

Mounting instructions



Interior mounting of the logic:

1. Put the screw-driver into the gap of the enclosure front, push the screw-driver up and open the enclosure.
2. Remove the control PCB (which is force fitted to the inside of the enclosure).
3. Locate the screwed glands supplied (sealing nipple left side) in the enclosure and replace the PCB. (Please ensure PCB is firmly in position)
4. Bore the fastening holes and fix the enclosure bracket at the wall.
5. The wires for the keyboard ensure through the left cable entry (sealing nipple), the wires for the relay contact through the middle cable entry and the wires for the supply voltage ensure through the right cable entry. Ensure tight seating of sealing nipple and cable gland, otherwise the water-protection of the appliance cannot be assured.
6. According to connection diagram connect the wires to the corresponding terminals:

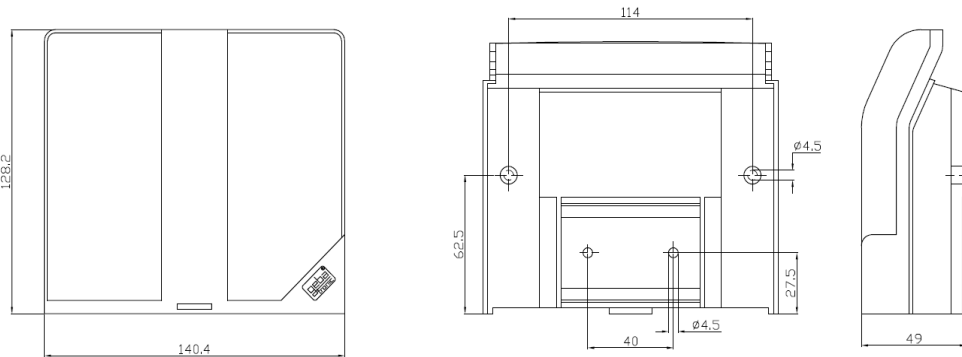
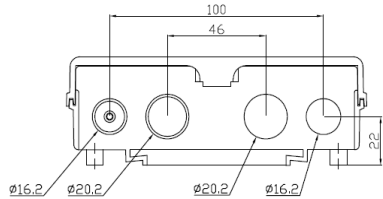

geba GmbH is released of its obligations regarding guarantee and product liability if – without prior permission - the unit has been modified, or if the installation is unproper or not in accordance with our instruction manual. The installer has to take care that the EMC-regulations are respected.

RC transmitter



Program 2 Deleting of remote controls

Delete specific transmitter:

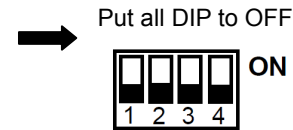
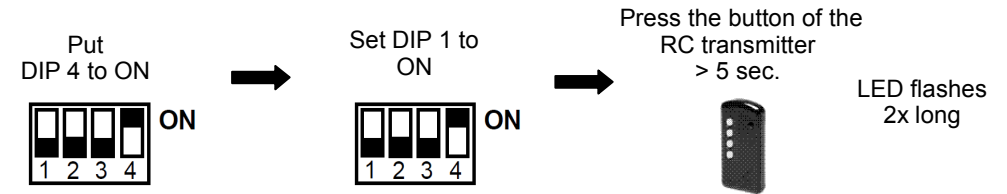

The specific transmitter is now deleted!

Delete all transmitters :

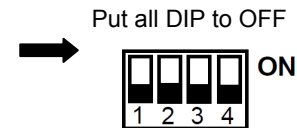
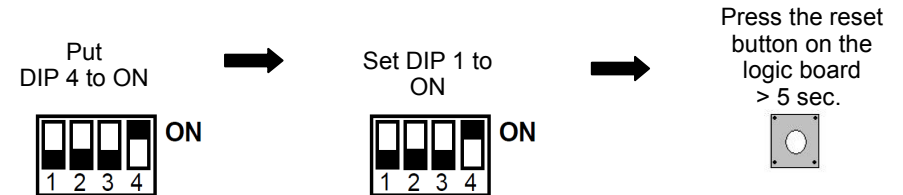

The taught-in transmitters are now all deleted !



Program 1
Teach-in of remote controls

Make sure before the teach-in that the optional wireless module is plugged in firmly at the logic board.

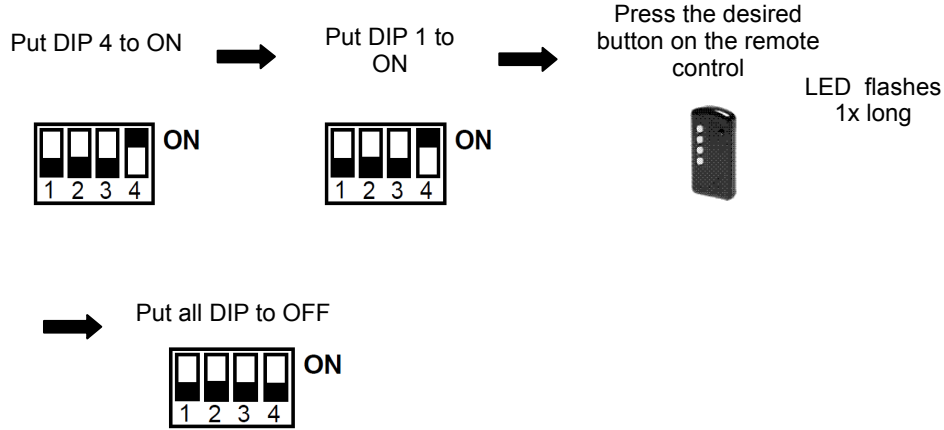

The transmitter is programmed !

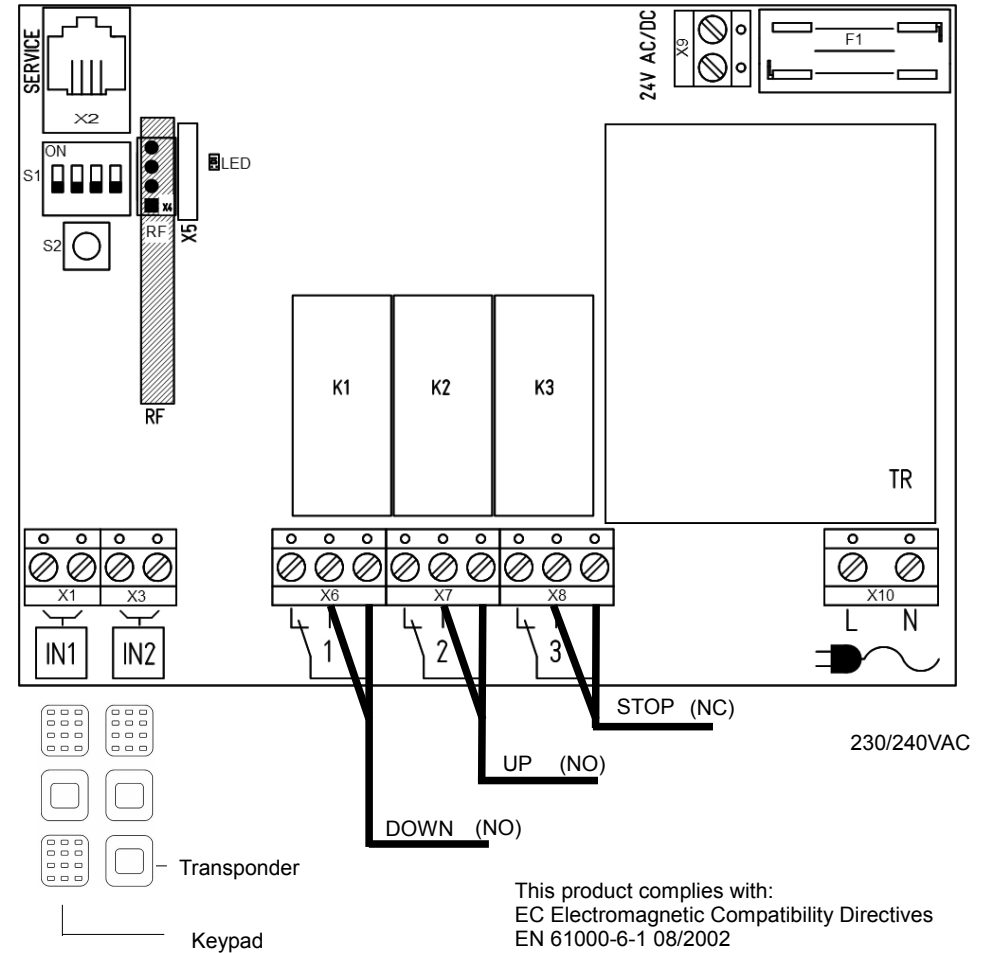

Technical Data:



Supply voltage: 20-28V AC/DC, 230-240 V AC
 Output: 250V AC 5A
 Connections: 1.5 mm² max.
 Ambient temperature: -20 °C to +60 °C

This product complies with:
 EC Electromagnetic Compatibility Directives
 EN 61000-6-1 08/2002
 EN 61000-6-3 08/2002
 Low Voltage Directive 2006/42/EC

Programming instructions



Please read first - then do the programming!!!

Before programming your Cody Universal 3 with your personal codes, please check the faultless function of the appliance with the help of the factory's pass code 1234 and the  button. Usually, any programming is made via your personal mastercode. In order to get familiar with that kind of programming, you start with the input of a new pass code, which replaces the one preset by the factory (1234). The procedure is explained under item "Program 2". After that please change the factory set mastercode to your personal code of choice.

Attention / Note

In case you made a mistake on programming, you can start over again by pushing the  button

Program 1 Input of a new mastercode

Factory setting = 1-8

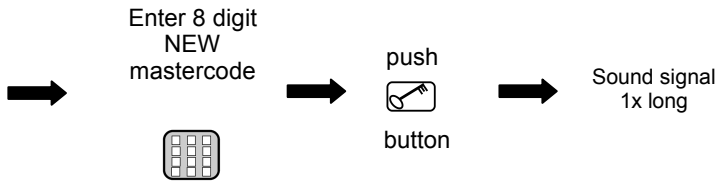
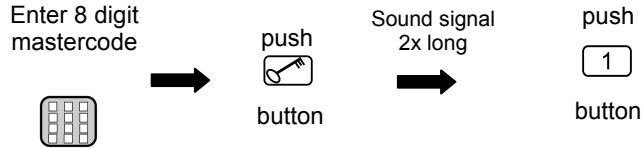

The new mastercode is now saved!

Program 2 Deleting transponder keys



Delete specific keys:



The individual transponder key is now deleted!

Delete all transponder keys of an individual relay or block:

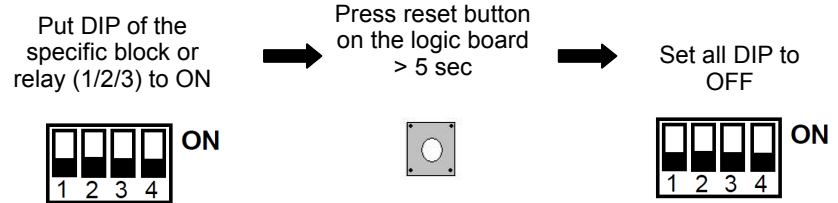

All keys of this specific block are now deleted !

Transponder



Program 1 Teach-in of transponder keys



The transponder key is programmed to the desired block!

* Note:
Cody Universal 3
The keys are distributed among three blocks with each 255 keys of on color. The blocks correspond to the first 3 DIP switches.

ATTENTION:
It is not possible to teach-in key different colors in one and the same block!
The reader should not be mounted directly on metal. Then use a spacer case (No. 508.000G.00).

Keypad



Program 2 Creating a new pass code

Factory setting = 1-4

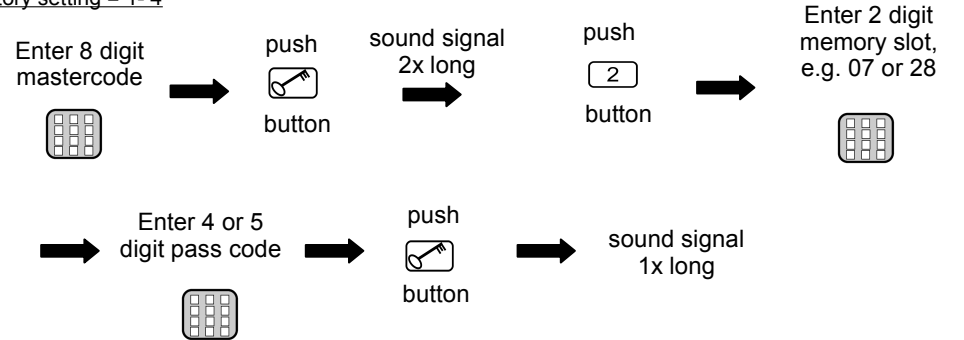

The new pass code is now saved!

The entered pass code is now stored in the selected memory slot !

You can enter up to 50 different pass on the memories 00-49!

Program 3 Deleting a pass code

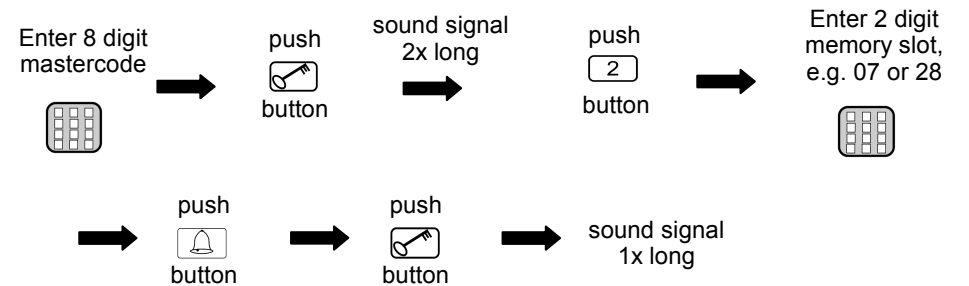

The selected memory slot of the pass code is now deleted!

Keypad

Program 4 Changing the control time / Tiptomatic time

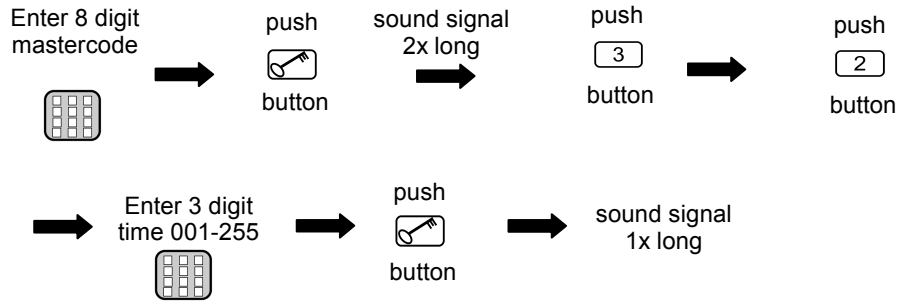

The modified Tiptomatic time is saved!
This set time is the same for all relays (factory 60 sec.).

Program 5 Changing the control time - lock-out time

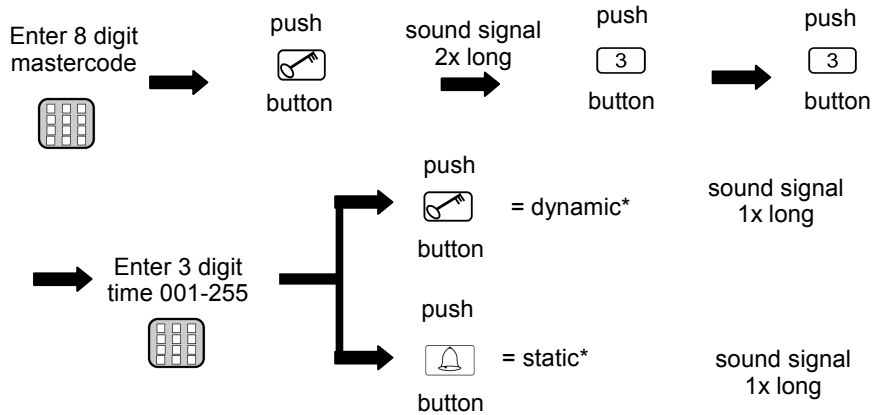

***Lock out time:**

dynamic = The lock-out time is extended by 10 sec. with every wrong entry (max. 255 sec.)

static = The lock-out time is according the set time(000 = turned off)

The modified lock-out time is saved!

Keypad

Program 6 Entering a pass code

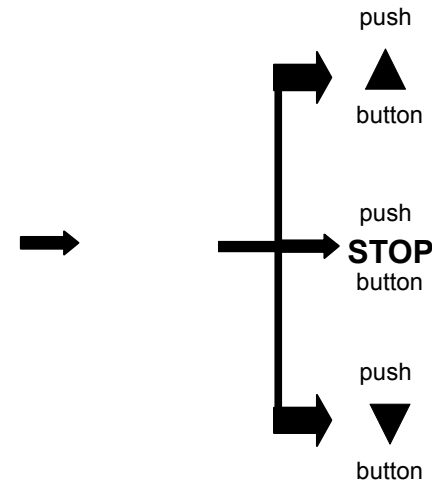

A correct code is detected, the corresponding relay is switched!

Before the actual pass code, you can press any other keys to prevent fraud.

If an incorrect pass code is entered, you will hear a sound signal (3 beeps).
Entering a new pass code is only possible after the lock-out period (factory: 20 sec.) which end is signalled by a long sound signal.