

CDO Ex d Operators Datasheet

Product Information

Product Data

Product Dimensions

Hazardous areas are places in which a dangerous explosive atmosphere exists as a result of local and operational conditions. Marantec UK offer many operators and controls off the shelf and can design and build custom solutions for hazardous area applications. The CDO Ex d operators are flangemount operators that provide solutions for door automation within a hazardous area.



CDO EX d 200B

Product Description

The CDO 200B flange mount, roller shutter operator from the CDO Exd range are specially designed for use in areas where there is a risk of explosion.

The CDO-200B Explosion Proof Operator is available in 0.75kw power size with 400v Three Phase Explosion Proof motor. This model uses an industrial duty motor and hence provides high starting torque. It is also fitted with a 30mm diameter shaft which enables to use conventional driving accessories. The operator comes with an ATEX rating of ZONE 1 & 2 OR 21 & 22, IIB, T4 Rated Operators (Gas OR Dust).

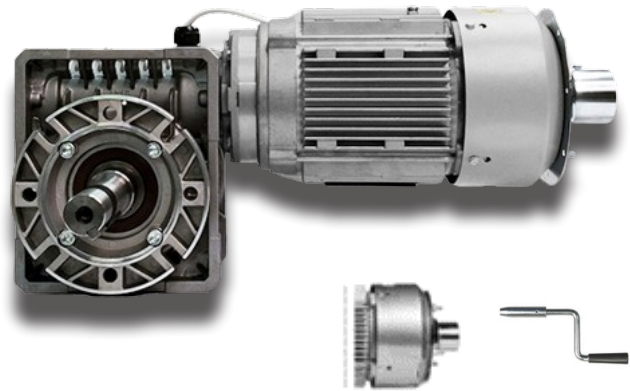

Stock Code: 21-2504

Product Features

- I.P. 54 environment protection
- High starting torque - industrial duty explosion proof motor
- Industry standard 30mm shaft
- IIC, T4 available on request
- Hand crank operation

Technical Information	CDO-200B
Power (kW)	0.75
Torque (Nm)	143
Output Speed (R.P.M.)	28
Environmental Protection	IP.54
Current (Amps)	1.9
Power Supply	400V 3ph 50Hz

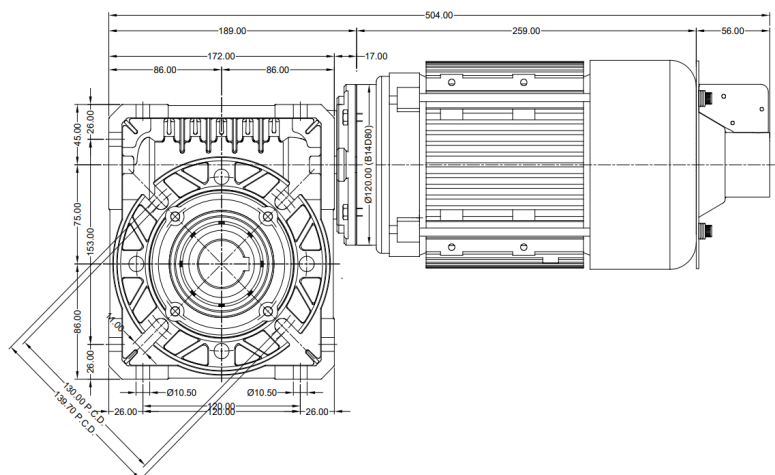
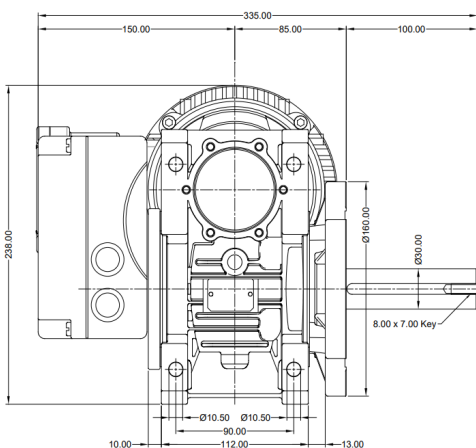

CDO EX d 300B

Product Description

The CDO 300B flange mount, roller shutter operator from the CDO Exd range are specially designed for use in areas where there is a risk of explosion.

The CDO-300B Explosion Proof Operator is available in 1.5kW power size with 400V Three Phase Explosion Proof motor. This model uses an industrial duty motor and hence provides high starting torque. It is also fitted with an industry standard 40mm shaft which enables to use conventional driving accessories. The operator comes with an ATEX rating of ZONE 1 & 2 OR 21 & 22, IIB, T4 Rated Operators (Gas OR Dust)



Stock Code: 21-2503

Product Features

- I.P. 54 environment protection
- High starting torque - industrial duty explosion proof motor
- Industry standard 40mm shaft
- IIC, T4 available on request
- Hand crank operation

Technical Information	CDO-300B
Power (kW)	1.5
Torque (Nm)	332
Output Speed (R.P.M.)	28
Environmental Protection	IP.54
Current (Amps)	3.6
Power Supply	400V 3ph 50Hz

