

Detail

WARNING! Read these instructions **FULLY** before use. Installation should only be carried out by a **COMPETENT** installer.

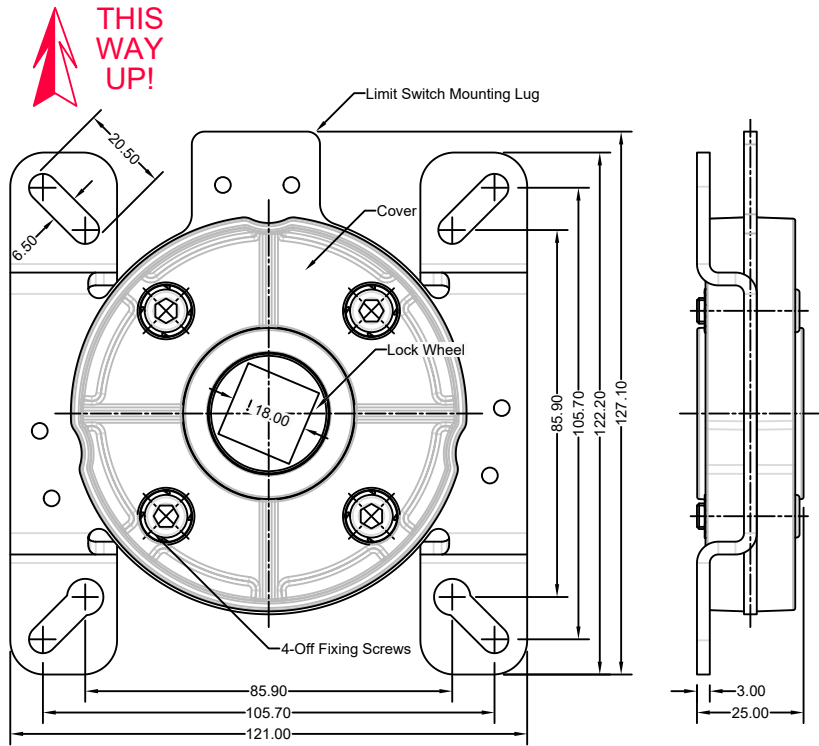

Typical Safety Brake Connections

Example 1: Tube Motor

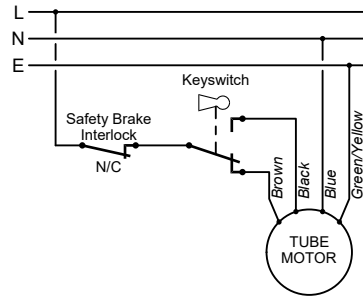

Data Table

Type	TSN0-F
Stock Code	29-0143
Max. Intercept/Check Moment (Nm)	591
Max. Permissible Torque (Nm)	145
Max. Operating Speed (rpm)	22
Unit Weight (Kg)	0.83
Torque Value of Locking Screws (Nm)	14
Temperature Range	-20°C...+60°C
Switch Protection Grade (If Fitted)	IP65
Test No.	240 42140-2

IMPORTANT: Ensure that the brake is absolutely vertical i.e. The limit switch lug is sited at the top.

Mounting Instructions

1. The safety brake **MUST** be installed on the opposite side to the drive. **Note:-** The safety brake is bi-directional and can therefore be mounted independently of the door movement.
2. Ensure that the safety brake is centrally fitted to the barrel, as any eccentric movement will cause the safety brake to actuate.
3. To ease installation of the safety brake, use lubricant on the shaft of the barrel. Never use force when fitting the safety brake.
4. Check that the drive torque at the barrel will not exceed the capacity of the safety brake.
5. If the safety brake is supplied with an interlock switch, ensure that it is connected and operational.

Visual Inspection

Once installed, check that the fixing screws are properly tightened and ensure that the interlock switch is operational.

Performance Checks

Check the safety brake by ensuring that the drop noise of the catch rolls is audible during both the forward & backward door motion.

Adjustment after Accidental Activation

Loosen the four screws holding the safety brake casing, ensuring that the casing does not come apart.

Provided that the lock wheel & cover are undamaged, turn the cover section, together with the lock wheel, until the limit switch mounting lug is positioned at the top of the unit.

Re-tighten the four screws to the correct torque of 14Nm.



Title:-

TSN0-F SAFETY BRAKE c/w SHALLOW MOUNTING BRACKET
(STOCK CODE: 29-0143)

Drawing No:- LC-2993

Page No:- 1 of 1

Revision No:- A

Rev Date:- 05/12/19

Drawn By:- R.A.H.

Date:- 21/03/12

Checked By:- M.T.

Appr' By:- S.L.