

**EN** Operating instructions  
Last updated: 07.2020

# Operator systems for collective garages

## Comfort 390

works with



**E** **O** **S** EASY  
OPERATING  
SYSTEM

MSBUS 

## Table of contents

<b>1.</b>	<b>Safety information.....</b>	<b>3</b>
1.1	Correct use.....	3
1.2	Target groups.....	3
1.3	General safety advice.....	3
<b>2.</b>	<b>Product information.....</b>	<b>4</b>
2.1	Scope of delivery.....	4
2.2	Scope of delivery - rail.....	5
2.3	Technical specifications.....	5
2.4	Gate variations.....	6
2.5	Example application.....	7
<b>3.</b>	<b>Installation.....</b>	<b>7</b>
3.1	Safety instructions for installation.....	7
3.2	Preparation for installation.....	7
3.3	Installing the drive.....	8
3.4	Connection.....	12
3.5	Completing the installation.....	18
<b>4.</b>	<b>Commissioning.....</b>	<b>19</b>
4.1	Safety instructions for commissioning.....	19
4.2	Overview of the controller.....	19
4.3	Status indication.....	20
4.4	Factory settings.....	20
4.5	Quick programming.....	20
4.6	Function test.....	21
4.7	Marantec Service Access (MSA).....	22
4.8	Special programming.....	23
<b>5.</b>	<b>Operation.....</b>	<b>30</b>
5.1	Safety instructions for operation.....	30
5.2	Remote controls.....	30
5.3	Release.....	30
<b>6.</b>	<b>Care.....</b>	<b>31</b>
<b>7.</b>	<b>Maintenance.....</b>	<b>31</b>
7.1	Maintenance work by the operator.....	31
7.2	Maintenance by qualified specialist personnel.....	31
<b>8.</b>	<b>Disassembly.....</b>	<b>32</b>
<b>9.</b>	<b>Disposal.....</b>	<b>32</b>
<b>10.</b>	<b>Troubleshooting.....</b>	<b>32</b>
<b>11.</b>	<b>Attachment.....</b>	<b>34</b>
11.1	Manufacturer's declaration.....	34
11.2	Radio conformity.....	35

## About this document

- Original operating manual.
- Part of the product.
- Reading and subsequent storage mandatory.
- Protected by copyright.
- No part of this manual may be reproduced without our prior consent.
- Subject to changes which are in the interest of technical improvements.
- All dimensions in millimetres.
- Figures are not to scale.

### Safety instructions

#### **WARNING!**

Safety information regarding a danger that can lead to death or serious injuries.



#### **CAUTION!**

Safety information regarding a danger that can lead to minor or moderate injuries.

#### **NOTICE**

Safety information regarding a danger that can lead to damage or destruction of the product.

### Meaning of symbols

- Action prompt
- ✓ Check
- List, itemisation
- Reference to other parts of this document
-  Reference to separate documents that must be observed
-  Factory settings

# 1. Safety information

## WARNING!

### **Risk of death due to a failure to observe the operating manual!**

This manual contains important information for handling the product safely. Particular reference is made to possible dangers.

- Read this manual through carefully.
- Follow the safety instructions in this manual.
- Store the manual in an accessible location.

## 1.1 Correct use

The drive system is designed exclusively for opening and closing gates in multi-bay garage.

Use is only permissible:

- On counterbalanced sectional and up-and-over doors with anti-drop protection.
  - In dry rooms.
  - In technically faultless condition.
  - Following correct installation.
  - In compliance with the data in the technical specifications.
- "2.3 Technical specifications"

Any other use is deemed to be improper use.

## 1.2 Target groups

### 1.2.1 Operator

The operator is responsible for the building in which the product is used. The operator has the following tasks:

- Knowledge and safekeeping of the instruction manual.
- Instruction of all persons who use the door system.
- Ensure that the gate system is inspected and maintained regularly by qualified specialist personnel.
- Make sure that inspection and maintenance are documented in the inspection logbook.
- Safe and proper keeping of the inspection logbook.

### 1.2.2 Specialist personnel

Qualified specialist personnel are responsible for assembly, commissioning, maintenance, repair, disassembly and disposal.

Requirements applicable to qualified specialist personnel:

- Knowledge of the general and specific safety and accident-prevention regulations.
- Knowledge of the relevant electrical regulations.
- Training in the use and care of appropriate safety equipment.
- Knowledge of the application of the following standards
  - EN 12635 ("Doors and gates - Installation and use"),
  - EN 12453 ("Safety in use of power operated doors - Requirements"),
  - EN 12445 ("Gates - Safety in use of power operated gates - Test methods").
  - EN 13241-1 ("Gates - Product standard - Part 1: Products without fire resistance or smoke control characteristics")

Electrical work must be performed by qualified electricians exclusively, in accordance with DIN VDE 0100

Requirements applicable to qualified electricians:

- Knowledge of the basics of electrical engineering.
- Knowledge of national regulations and standards.
- Knowledge of the relevant safety regulations.
- Knowledge of this operating manual.

### 1.2.3 Users

Instructed users operate and care for the product.

Requirements applicable to instructed users:

- Users are instructed in relation to their work by the operator.
- Users must have been instructed on how to use the product safely.
- Knowledge of this operating manual.

Special requirements apply to the following users:

- Children aged 8 and above.
- Persons with reduced physical, sensory or mental capabilities.
- Persons with a lack of experience and knowledge.

These users are only authorised to operate the product.

Special requirements:

- The users must be supervised.
- Users must have been instructed on how to use the product safely.
- The users must understand the dangers involved in handling the product.
- Children are not allowed to play with the product.

## 1.3 General safety advice

Persons or objects must never be moved with the aid of the gate.

In the following cases, the manufacturer accepts no liability for damages. The guarantee on the product and accessory parts is voided with:

- A failure to observe these operating instructions.
- Misuse and improper handling.
- The assignment of unqualified personnel.
- Modifications or changes to the product.
- The use of spare parts that have not been produced or approved by the manufacturer.

The product is manufactured according to the directives and standards mentioned in the Declaration of Incorporation. The product has left the factory in perfect condition with regard to safety.

Batteries, accumulators, fuses and bulbs are excluded from warranty.

### **Further safety information can be found in the relevant respective sections of the document.**

- "3.1 Safety instructions for installation"
- "4.1 Safety instructions for commissioning"
- "5.1 Safety instructions for operation"



## 2. Product information

### 2.1 Scope of delivery



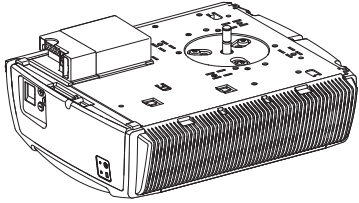
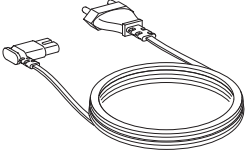
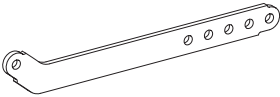
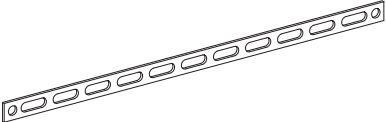
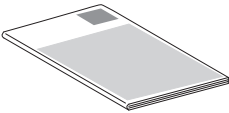

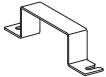
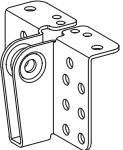
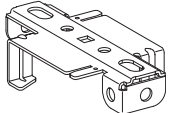

- Refer to the table for the supply package applicable to your product variant.

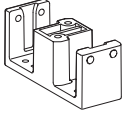

Country-specific deviations are possible.

Pos.		
1		1x
2		1x
3		1x
4		2x
5		1x

Pos.	#1	A	B
6		2x	2x
7		1x	1x
8		2x	2x
9		1x	-

Pos.	#1	A	B
10		1x	-
11		-	1x

Pos.	#2	A	B
12		4x	4x
13		1x	1x
14		1x	1x
15		1x	1x
16		1x	-
17		1x	-
18		-	4x

Pos.	#3	
19		6x
20		6x
21		6x

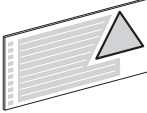



Pos.	Warning signs	
22		1x
23		1x

## 2.2 Scope of delivery - rail

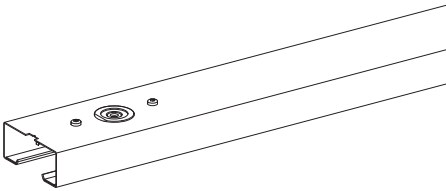
- Refer to the table for the supply package applicable to your product variant.

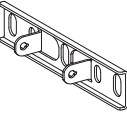
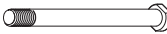
Country-specific deviations are possible.

Pos.		
24		1x

Pos.	#4	A	B
25		1x	1x
26		1x	1x
27		1x	1x
28		2x	2x
29		1x	1x

## 2.3 Technical specifications

Electrical specifications			
Rated voltage, national variations possible*	V	EU JP USA	230 100 120
Rated frequency*	Hz		50 / 60
Current consumption*	A	EU JP USA	1.1 2.5 2.1
Power consumption in operation**	kW		0.25
Power consumption in standby**	w		approx. 3.5
Control voltage	V DC		24
Protection category for motor unit			IP 20
Connection unit protection category			IP 65
Motor unit protection category			II
Connection unit protection class			I

\* The drive-specific values can be found on the type plate on the motor unit.

\*\* Without accessories connected

Mechanical specifications		
Max. push and pull force	N	1,200
Nominal force	N	360
Max. Travel speed	mm/s	160
Opening phase, specific to gate	s	13.0

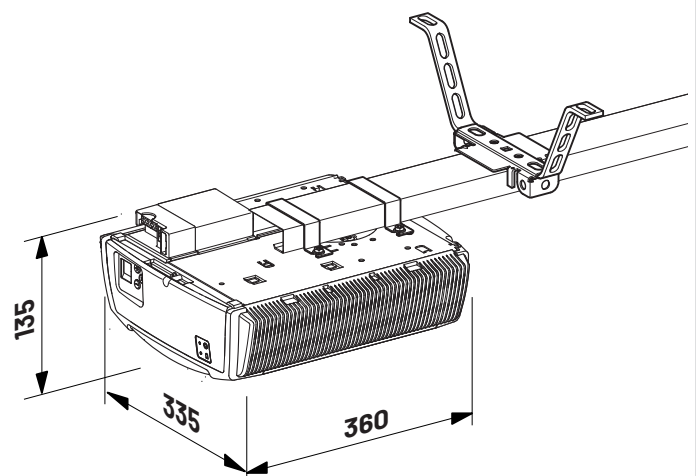

### Ambient specifications

Motor unit dimensions



Weight (motor unit)	g	5,000
Sound pressure level	dB(A)	< 70

**Ambient specifications**

Temperature range		°C	-20
		°C	+60

**Area of application**

Swing-out overhead door			
- max. gate width	mm		6,000
- max. gate weight	kg		240
single-wall sectional gate			
- max. gate width	mm		6,000
- max. gate weight	kg		240
double-wall sectional gate			
- max. gate width	mm		6,000
- max. gate weight	kg		240
Tilt and canopy gate			
- max. gate width	mm		6,000
- max. gate height	mm		2,250
- max. gate weight	kg		240
max. Cycles per hour	cph		18
max. Cycles per day	cpd		300
max. Number of parking spaces			100

**2.4 Gate variations**

The scope of supply with corresponding drive rail is suitable for the following types of gate.

**Swing-out overhead door (up-and-over door)**

2.4 / 1

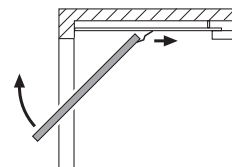

**Sectional gate**

2.4 / 2

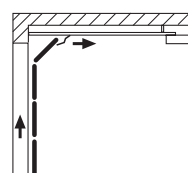

Special accessories are required for the following gate versions.

**Non-swing-out overhead door**

2.4 / 3

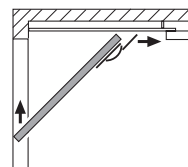

**Side sectional gate**

2.4 / 4

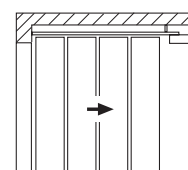

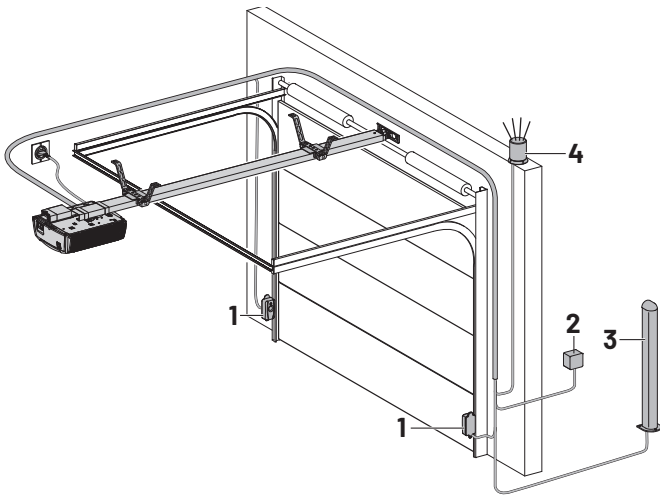

## 2.5 Example application

2.5 / 1



The gate system is an example and may vary depending on gate type and equipment. The system shown consists of the following components:

- 1 Photocell
- 2 Key switch
- 3 Post (for code buttons, transponders, etc.)
- 4 Signal light

-  Further information regarding the accessories can be found on the manufacturer's website.
-  For the installation and cabling of the gate sensors, control elements and safety equipment, the relevant installation instructions must be observed.

## 3. Installation

### 3.1 Safety instructions for installation

#### **WARNING!**

##### **Danger due to a failure to observe the installation instructions!**

This chapter contains important information for the safe installation of the product.

- Read this chapter through carefully before installation.
- Follow the safety instructions.
- Perform the assembly as described.

Assembly by qualified specialist personnel only.

→ "1.2.2 Specialist personnel"

Electrical work must be performed by qualified electricians exclusively.

→ "1.2.2 Specialist personnel"

- Before assembly, it is necessary to make sure that the power supply has been and remains disconnected. Only establish the power supply when prompted to do so in the corresponding assembly step.
- It is essential to adhere to the local protection regulations.
- It is essential that mains supply cables and control cables are laid separately. The controls voltage is 24 v DC.
- The gate must be in good mechanical condition:
  - The gate comes to a stop in any position.
  - The gate is easy to move.
  - The gate opens and closes correctly.
- All pulse transmitters and control devices (e. g. remote control buttons) must be installed within sight of the gate and at a safe distance from the moving parts of the gate. A minimum installation height of 1.5 metres must be observed.
- Only use fixing material that is suitable for the respective construction substrate.

### 3.2 Preparation for installation

Before starting installation, it is essential to perform the following work.

#### **Scope of delivery**

- Check which product variant you have, and ensure the scope of delivery is complete.
- Make sure that a suitable drive rail is available.
- Check that you have all the accessory parts required for your installation.

#### **Garage**

- Check whether your garage is equipped with a suitable power connection and circuit breaker.

### Gate system

- Remove all unnecessary components from the gate (e. g. cables, chains, brackets, etc.)
- Render any installations inoperable that will no longer be needed after the operator system has been installed.

In the case of garages without a second access:

- Equip the garage gate with an emergency interlock, so that the garage can be entered in the event of a malfunction.

If a release set is used:

- Check the correct function of the gate locks. The function of the gate locks must never be disabled.

If a release set is not used:

- Remove the gate locks or disable the gate locks.

 When using and installing accessories, always observe the corresponding documentation.

## 3.3 Installing the drive

### 3.3 / 1

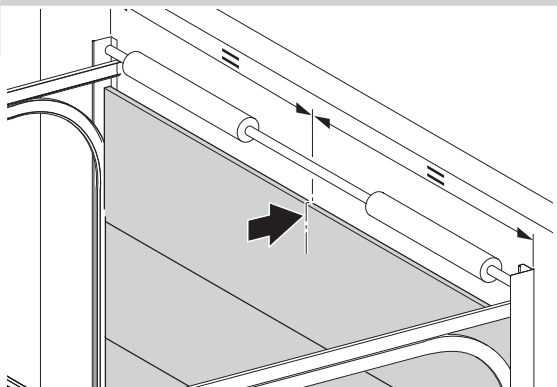

### 3.3 / 2

#### 3.3 / 2 a

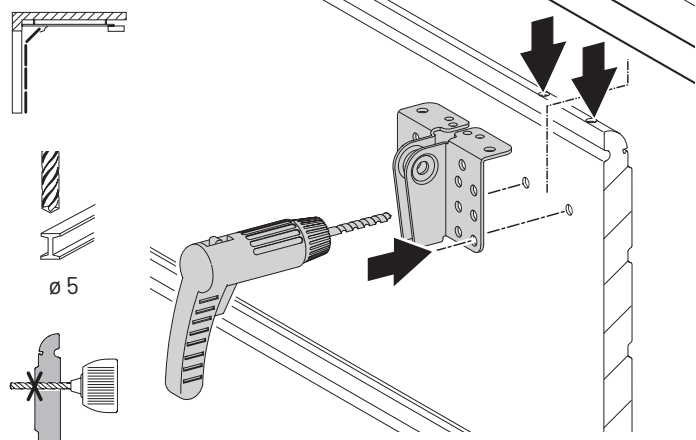

4x



10

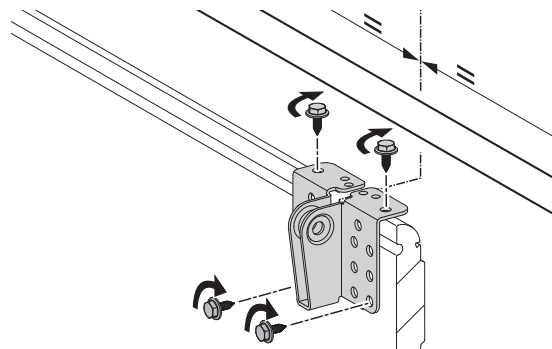

### 3.3 / 2 b

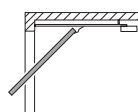

ø 5

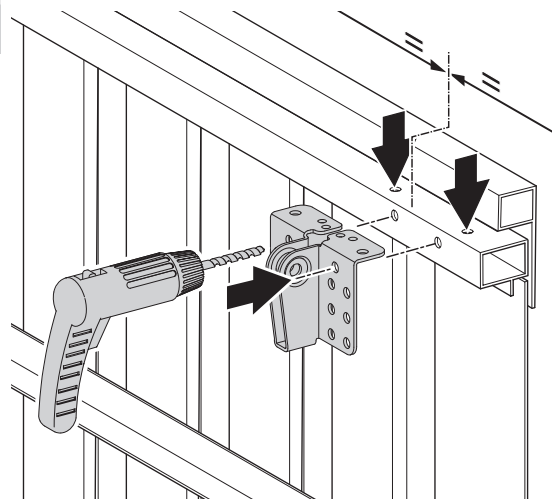
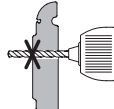

4x



10

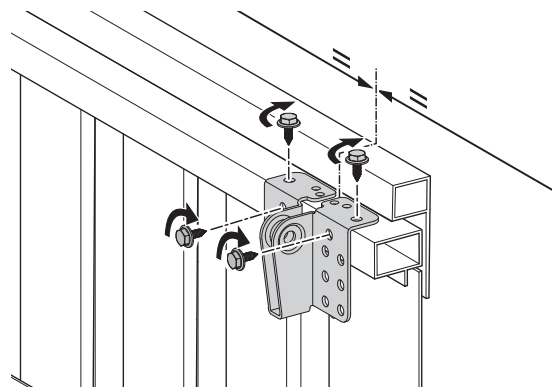

### NOTICE

#### Danger due to shaft adapter damage caused by the application of force!

Impacts with a hammer can damage the tothing of the shaft adapter.

- Proceed with caution when mounting the drive rail on the motor unit.



3.3 / 3

3.3 / 3 a



1x



10



25

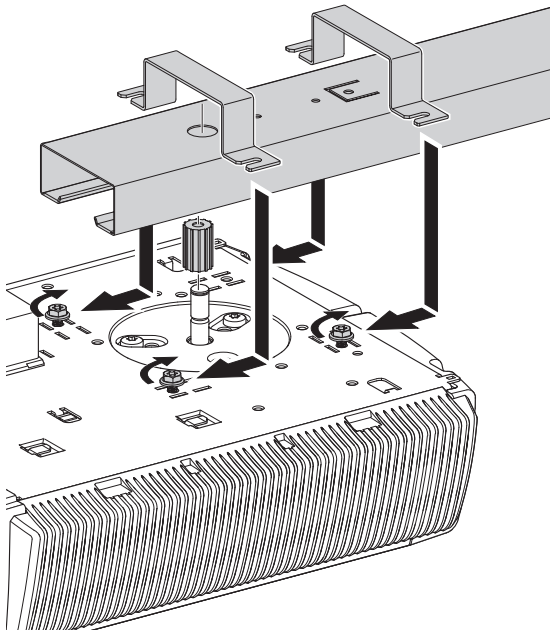

 **WARNING!**

**Risk of injury due to loose components!**

Falling parts can cause serious injuries.

- Secure the drive system against falling until it is securely fastened.

3.3 / 5

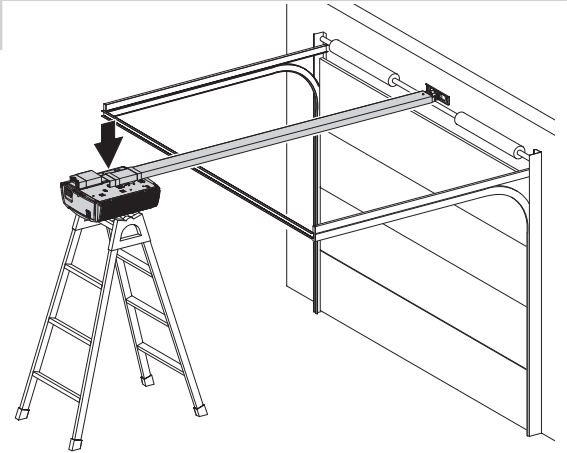

3.3 / 3 b



1x



10



25

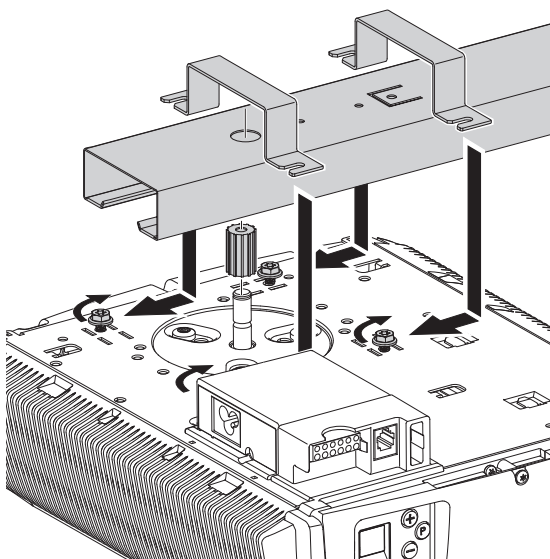

 **NOTICE**

**Risk of damage to the door panel due to incorrect assembly!**

Incorrect installation of the lintel connection plate can lead to collision of the door panel with the drive rail.

- Make sure the top edge of the gate leaf at the highest point of the opening track is 10 - 50 mm beneath the horizontal lower edge of the drive rail.
- Mount the lintel connection plate for the drive rail centrally above the gate leaf.

3.3 / 4



1x



1x



10

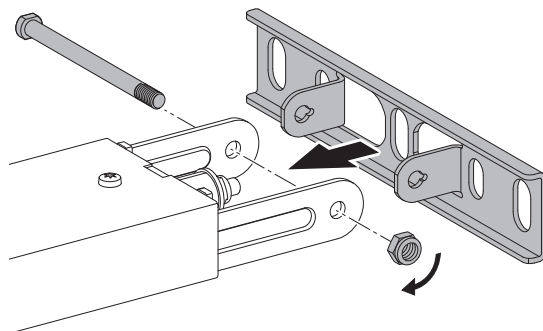

3.3 / 6



ø 10

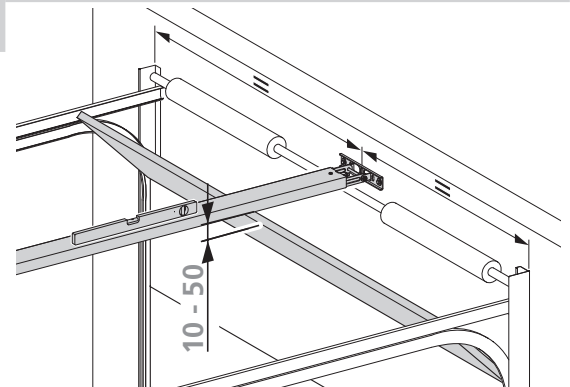

**3.3 / 7**



2x



2x



2x



13

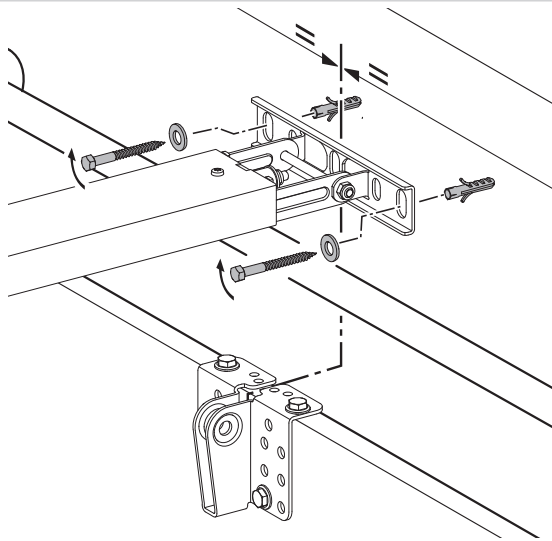

**3.3 / 8**



1x



1x

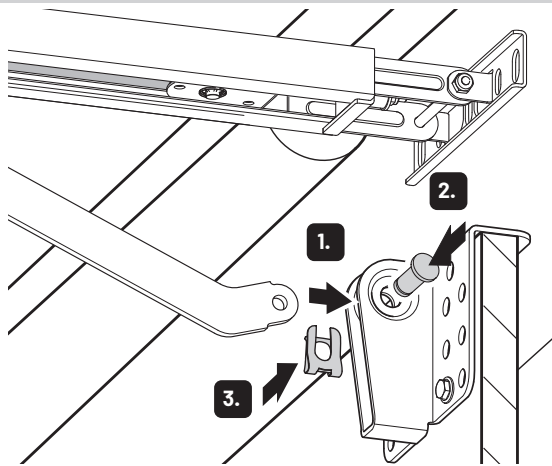

**3.3 / 9**

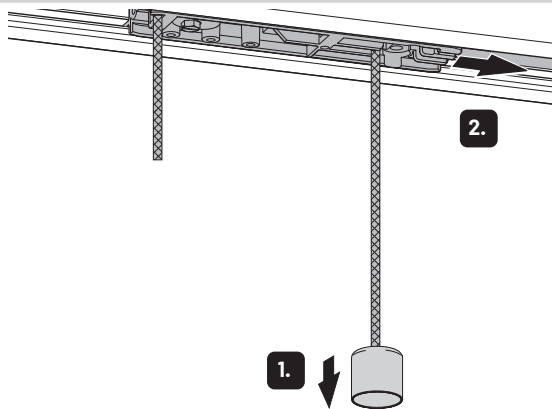

**3.3 / 10**



1x



2x



25

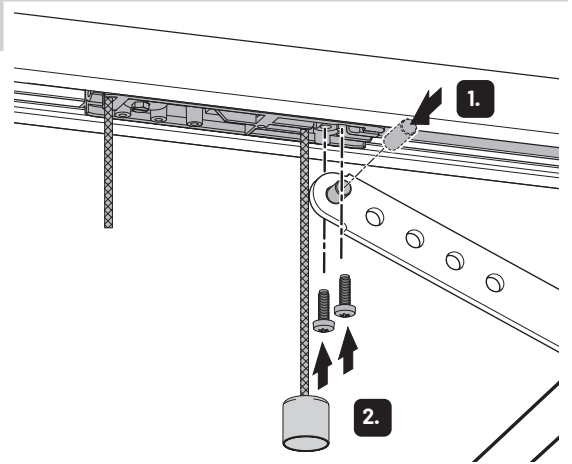

**3.3 / 11**

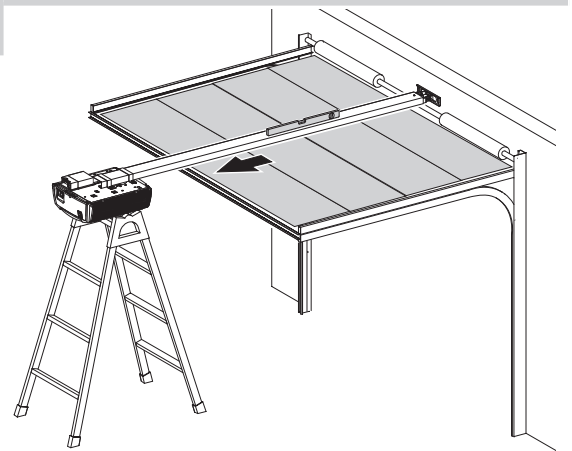

**3.3 / 12**

**3.3 / 12 a**



1x



1x



10

a = 90°  
b = 9 Nm

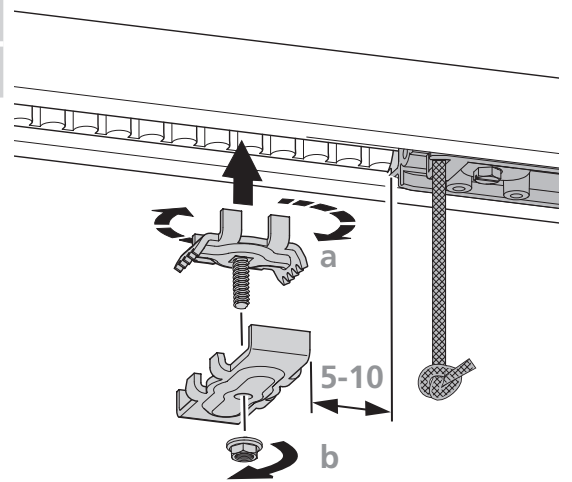

3.3 / 12 b

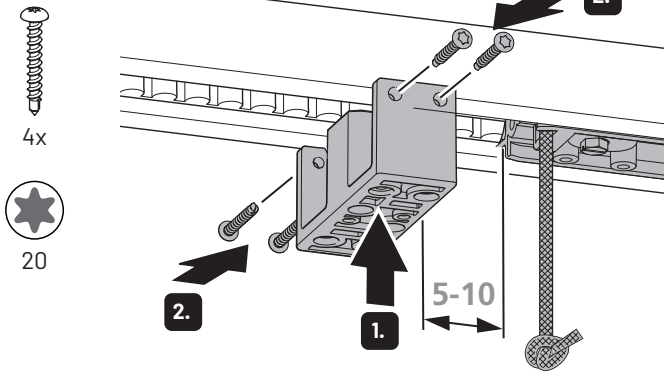

3.3 / 15

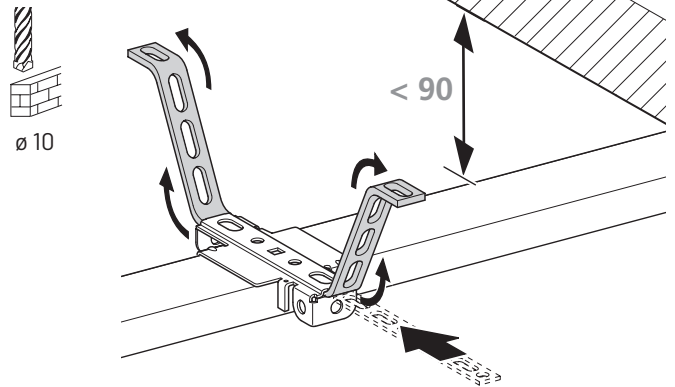

3.3 / 13

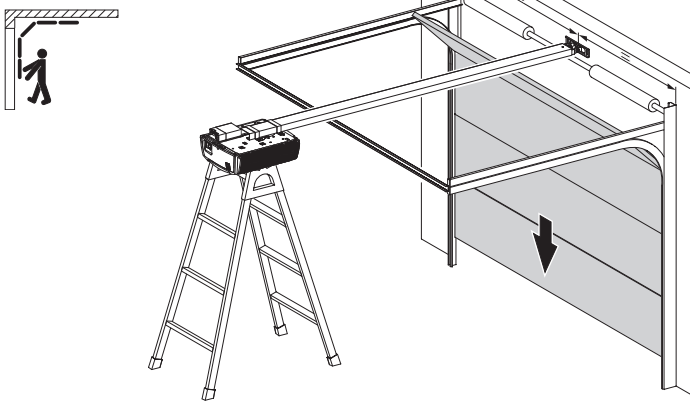

3.3 / 16

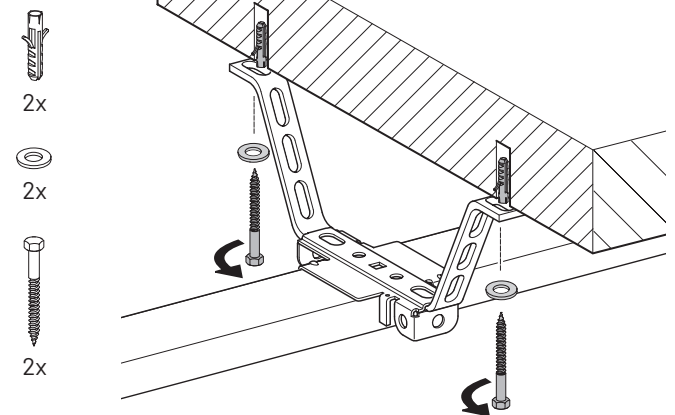

3.3 / 14

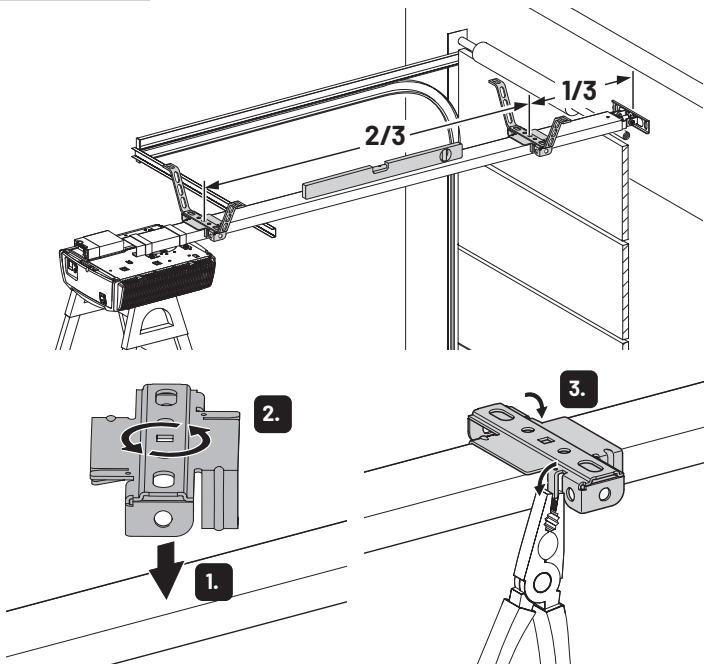

3.3 / 17

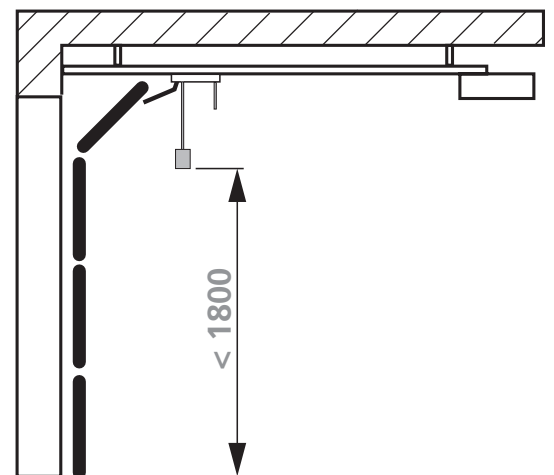

**Tip:**

The hand cable can be fastened to the gate with the aid of the self-adhesive cable retainer. This prevents the hand cable catching and resulting in damage (e.g. with roof rack systems).

### 3.4 Connection

#### WARNING!

##### Risk of fatal injuries due to electric shocks!

Contact with live parts can lead to electric shock, burns and death.

- Ensure that the power supply is and remains disconnected throughout any wiring work.

#### NOTICE

##### Risk of material damage due to incorrect installation of the drive!

External voltage to the connection XB03 leads to destruction of the entire electronics.

- Only connect potential-free contacts to terminals 1, 2 and 4 (XB03).

#### 3.4 / 1

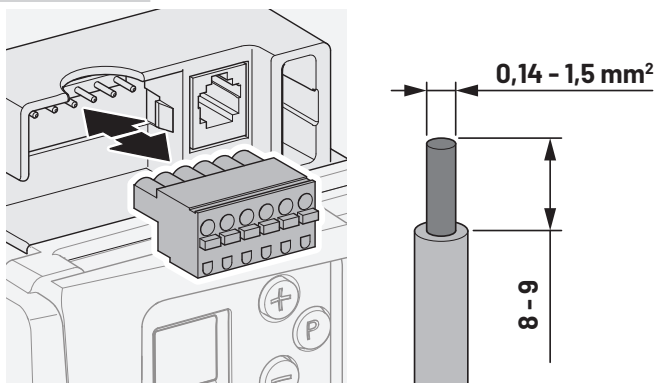

- Terminal XB03 can be plugged in for a simple connection.
- The cable must be stripped according to the terminal.

### 3.4.1 Overview of controller connections

#### 3.4.1 / 1

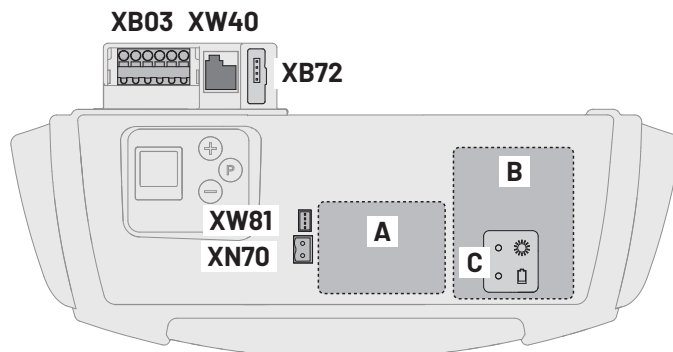

A	Expansion housing GDO
B	Battery backup slide-in unit
C	Battery backup display
XB03	Connection → "3.4.3 Potential-free button connection (XB03)" → "3.4.4 Connection of button with power supply (XB03)" → "3.4.5 2-wire photocell connection (XB03)" → "3.4.6 4-wire photocell connection (XB03)" → "3.4.7 Personnel door contact connection (XB03)"
XB72	Connecting the module receiver → "3.4.2 Module receiver connection (XB72)"
XN70	Connection of the battery backup → "3.4.8 Connection of XN70 and XW81"
XW40	Connection of the MS-BUS for expansion modules
XW81	Connection of expansion Inputs / Outputs → "3.4.8 Connection of XN70 and XW81"

### 3.4.2 Module receiver connection (XB72)

Product examples:

- Multi-Bit module receiver
- Module receiver bi•linked

#### 3.4.2 / 1

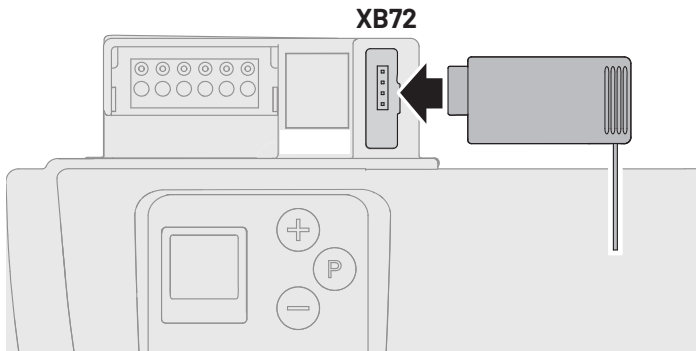

#### Level 4 – Radio programming

Only with bi•linked version:

Press the programming button on the rear side of the handheld transmitter before the button on the front side is pressed.

##### Menu 2 – Intermediate position OPEN

Parameter and hand-held transmitter display flashing  
-> Press hand-held transmitter button -> Hand-held transmitter display lights up briefly -> The function has been taught.

##### Menu 3 – Intermediate position CLOSED

Parameter and hand-held transmitter display flashing  
-> Press hand-held transmitter button -> Hand-held transmitter display lights up briefly -> The function has been taught.

##### Menu 4 – OPEN

Parameter and hand-held transmitter display flashing  
-> Press hand-held transmitter button -> Hand-held transmitter display lights up briefly -> The function has been taught.

##### Menu 5 – CLOSED

Parameter and hand-held transmitter display flashing  
-> Press hand-held transmitter button -> Hand-held transmitter display lights up briefly -> The function has been taught.

##### Menu 6 – Entry request

Parameter and hand-held transmitter display flashing  
-> Press hand-held transmitter button -> Hand-held transmitter display lights up briefly -> The function has been taught.

#### Level 4 – Radio programming

##### Menu 7 – Exit request

Parameter and hand-held transmitter display flashing  
-> Press hand-held transmitter button -> Hand-held transmitter display lights up briefly -> The function has been taught.

##### Menu 8 – Drive lighting ON / OFF or relay output

Parameter and hand-held transmitter display flashing  
-> Press hand-held transmitter button -> Hand-held transmitter display lights up briefly -> The function has been taught.

Relay output:

The parameter “radio remote control” must be programmed.

→ “Level 1, Menu 7 - Relay output”

### 3.4.3 Potential-free button connection (XB03)

Product examples:

- Push-button
- Key switch
- Ceiling pull switch

Possible functions:

- Pulse - open/stop/close a gate
- OPEN pulse - open a gate
- Premature closing in case of automatic feed

#### 3.4.3 / 1

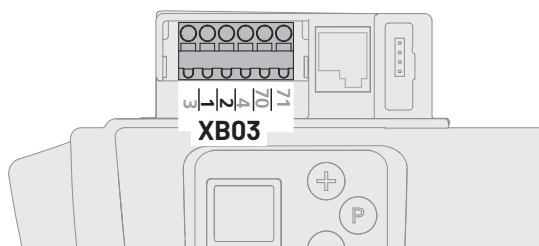

#### 3.4.3 / 2

M19E010e

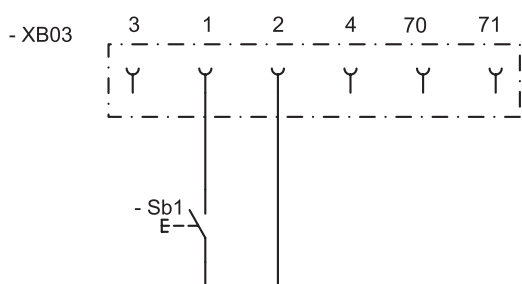

1	GND
2	Pulse
Sb1	Pulse button

#### 3.4.3 / 3

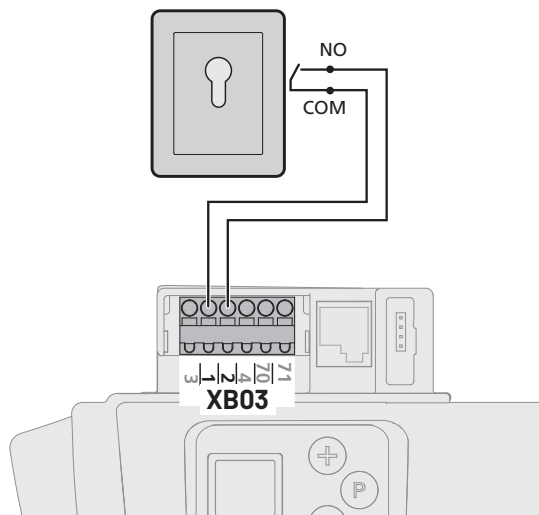

### Level 5 - Special functions

#### Menu 1 - Programmable pulse input (terminal 1/2)

1	Pulse (only NO)
5	OPEN pulse (induction loop - only NO)
6	Premature closing through actuation of button or hand-held transmitter > 2 seconds

For drives with energy saving technology (e.g BlueLine) select parameter 7 if the connected accessories must also be supplied with power in stand-by.

### 3.4.4 Connection of button with power supply (XB03)

Product examples:

- Radio receiver
- Transponder system
- Induction loop detector

Possible functions:

- Pulse - open/stop/close a gate
- OPEN pulse - open a gate

#### 3.4.4 / 1

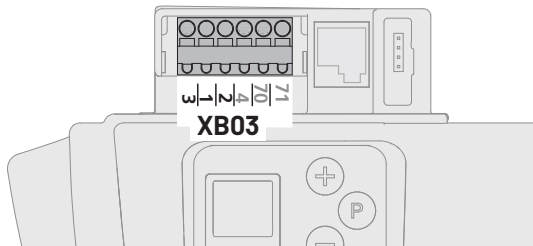

#### 3.4.4 / 2

M19E010e

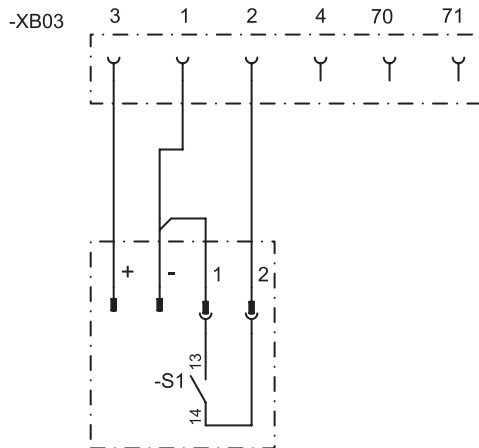

1	GND
2	Pulse
3	24 V DC / max. 50 mA
S1	Potential-free make contact

#### 3.4.4 / 3

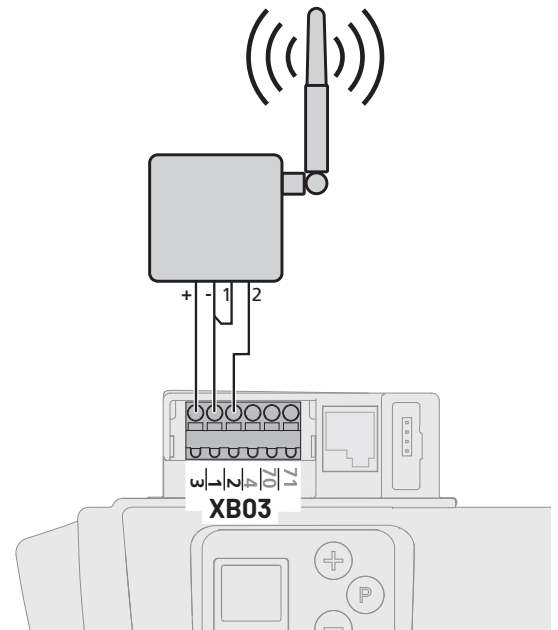

#### Level 5 - Special functions

Menu 1 - **Programmable pulse input (terminal 1/2)**

1	 Pulse (only NO)
5	OPEN pulse (induction loop - only NO)
6	Premature closing through actuation of button or hand-held transmitter > 2 seconds

### 3.4.5 2-wire photocell connection (XB03)

Possible function:  
Contactless obstacle detection in CLOSE direction

#### 3.4.5 / 1

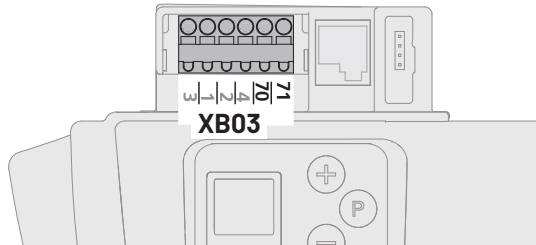

#### 3.4.5 / 2

M19E010e

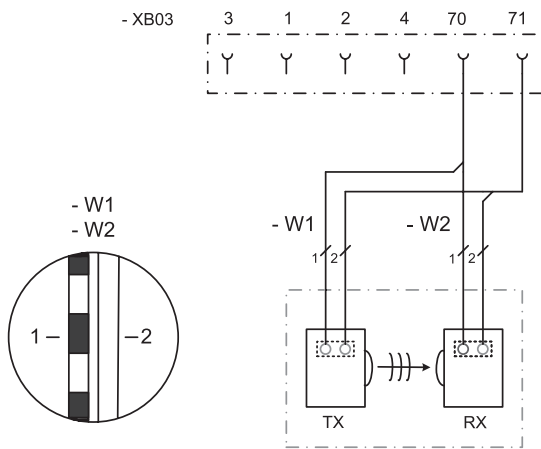

70	GND
71	Photocell
RX	Photocell receiver
TX	Photocell transmitter

#### 3.4.5 / 3

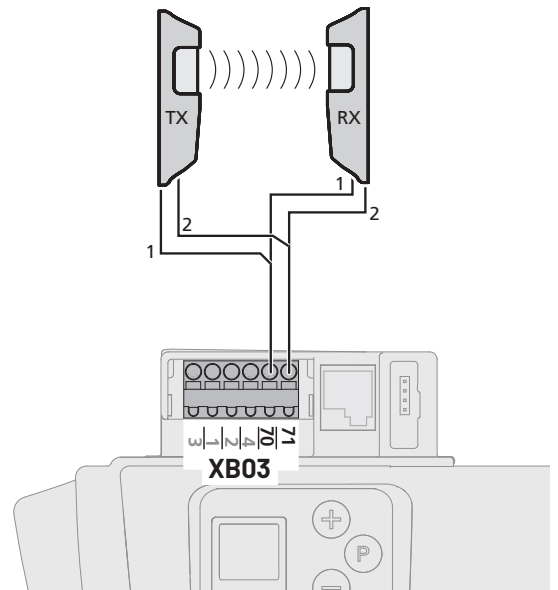

A connected photocell is automatically detected by the controller as soon as the power supply is connected. The photocell can be retrospectively reprogrammed. Unwanted photocells must be disconnected before the power supply is connected, otherwise the controller will detect them.

#### Level 8 – System settings

The following menus and functions are only accessible for qualified specialist personnel. The MSA is required for enabling the function.  
→ "4.7 Marantec Service Access (MSA)"

Gate reversal brief:

The drive system briefly moves the gate in the opposite direction to release an obstacle.

Gate reversal extended:

The drive system moves the gate to the OPEN gate position.

#### Level 8 – System settings

Menu 1 – Photocell

1	Operation without photocell
2	2-wire photocell (Connection XB03 - terminal 70/71), Gate movement CLOSE: Gate reversal extended



### 3.4.6 4-wire photocell connection (XB03)

Possible function:  
Contactless obstacle detection in CLOSE direction

#### 3.4.6 / 1

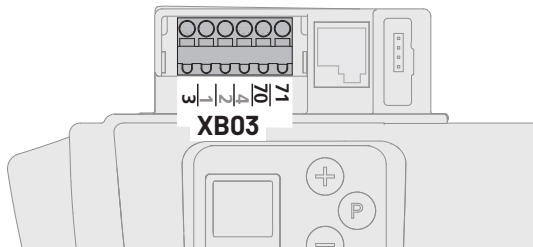

#### 3.4.6 / 2

M19E010e

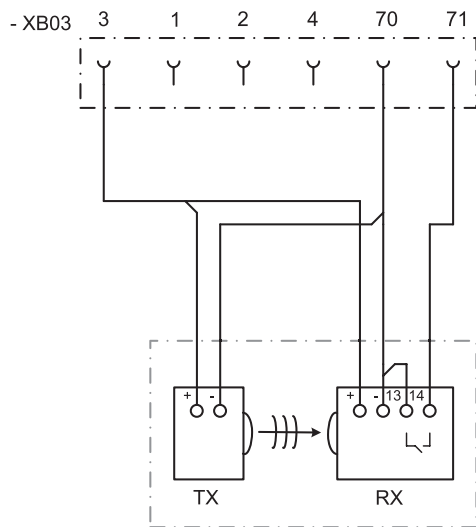

1	24 V DC / max. 50 mA
70	GND
71	Photocell
RX	Photocell receiver
TX	Photocell transmitter

#### 3.4.6 / 3

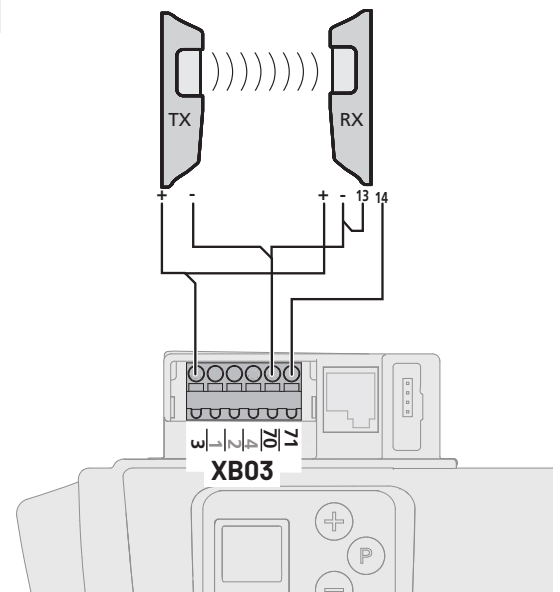

#### Level 8 - System settings

The following menus and functions are only accessible for qualified specialist personnel.  
The MSA is required for enabling the function.  
→ "4.7 Marantec Service Access (MSA)"

Gate reversal brief:

The drive system briefly moves the gate in the opposite direction to release an obstacle.

Gate reversal extended:

The drive system moves the gate to the OPEN gate position.

#### Level 8 - System settings

Menu 1 - **Photocell**

1	 Operation without photocell
3	External photocell (Connection XB03 - terminal 70/71), Gate movement CLOSE: Gate reversal extended

### 3.4.7 Personnel door contact connection (XB03)

Product examples:

- Personnel door contact opener (N.C.)
- Personnel door contact 8K2

#### 3.4.7 / 1

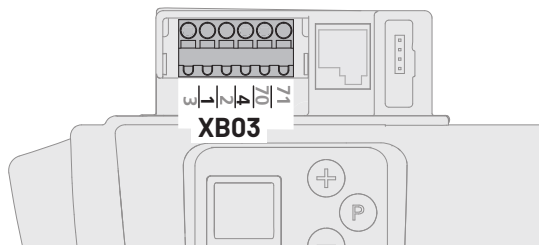

#### 3.4.7 / 2

M19E010e

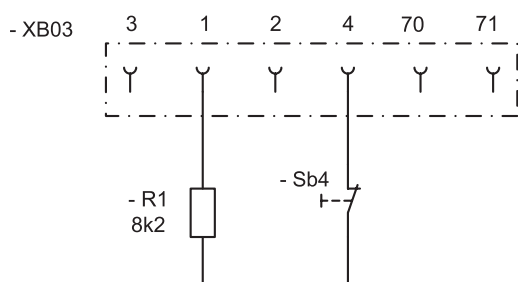

1	GND
4	Holding circuit, active after reset
Sb4	Personnel door contact
R1	Resistor 8K2

#### 3.4.7 / 3

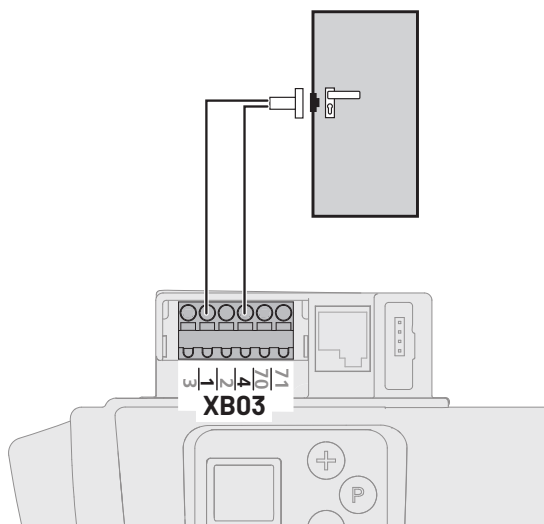

After connecting the accessory and the subsequent mains On, the controller automatically detects the accessory. The gate must be closed so that the personnel door contact can be correctly detected.

### 3.4.8 Connection of XN70 and XW81

#### 3.4.8 / 1



20

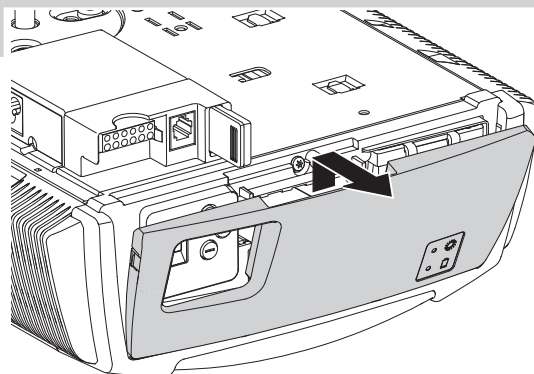

For a description of the connection element installation, refer to separate documentation.

#### 3.4.8 / 2



20

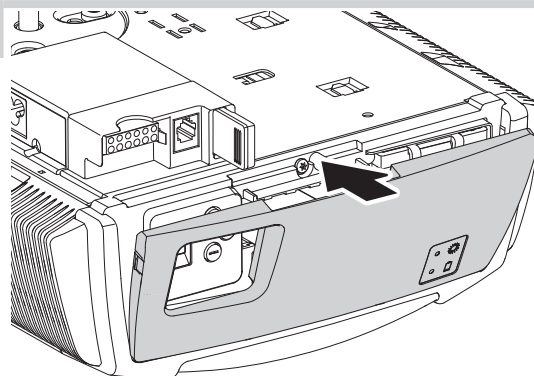

### 3.5 Completing the installation

- Attach the warning sign against the risk of entrapment in a conspicuous place.
- Ensure that no part of the gate extends across public footways or roads when the installation is complete.

#### 3.5 / 1

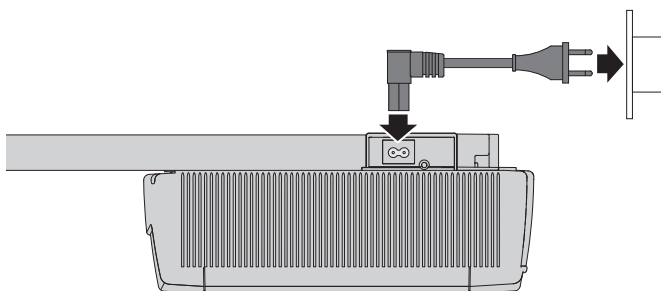

## 4. Commissioning

### 4.1 Safety instructions for commissioning

#### **WARNING!**

##### **Danger due to a failure to observe the commissioning instructions!**

This chapter contains important information for the safe commissioning of the product.

- Read this chapter through carefully before commissioning.
- Follow the safety instructions.
- Perform commissioning as described.

Commissioning must be performed by qualified specialist personnel.

→ "1.2.2 Specialist personnel"

Power-operated windows, doors and gates must be inspected by qualified specialist personnel before first commissioning and as required, although at least once a year, with a suitable closing force measuring device (written inspection records must be kept).

After initial operation, the persons responsible for operating the gate system, or their representatives must be familiarised with the use of the system.

- Children must not play with the gate control unit or the hand-held transmitter.
- No persons or objects are permitted inside the operating range of the gate.
- Before passing through the gate opening, make sure the gate is in the OPEN gate position.
- All available emergency command devices must be tested.
- Pay attention to any parts of the gate system that could cause crushing or shearing damage.
- Never insert your hands into a running gate, the guide rails or moving parts.
- The EN 13241-1 regulations ("Doors and gates - Product standard") must be observed.

### 4.2 Overview of the controller

#### Control elements



LCD display



Drive gate in OPEN direction,  
Increase parameter



Drive gate in CLOSED direction,  
Reduce parameter



Start programming, confirm and save values

#### Legend



Display flashing



Display illuminated

#### Display

#### Function / element



Ready for operation



Gate position CLOSED



Gate position OPEN



Error message / maintenance indication in  
gate position CLOSED



Photocell or closing edge safety device



Remote control



External button

3

Status indication  
(Example display 3 - Battery backup  
connected)  
→ "4.3 Status indication"

1 2 3 4 5 6 7 8 9 0

Display of the levels (example: Level 2)

1 2 3 4 5 6 7 8 9 0

8

Display of the menus and parameters  
(Example: Menu 3, parameter 8)

#### Minute display

1 2 3 4 5 6 7 8 9 0

1.2

Times of more than one minute are displayed  
in minutes and seconds.  
Example: 1.2 = 1 minute + 20 seconds =  
80 seconds

### 4.3 Status indication

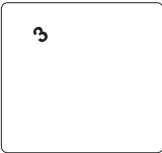
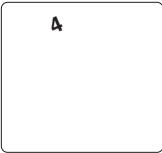
Display	Function / element
	Battery backup connected (optional)
	Pre-warning time display (only with programmed automatic closing)

### 4.4 Factory settings

The drive can be restored to the factory settings with a reset.  
→ "Level 1, Menu 8 - RESET"

### 4.5 Quick programming

It is necessary to perform quick programming for correct commissioning of the drive system and after a reset.

Preconditions:

- The gate is in the CLOSED gate position.
  - The guide carriage is engaged.
- "5. Operation"

If no button is pressed for 120 seconds in programming mode, the controller changes back to operating mode. A corresponding error number is displayed.  
→ "10. Troubleshooting"

- Perform the quick programming.
  - ✓ It is necessary to perform a functional test after quick programming.
- "4.6 Function test"

#### NOTICE







**Danger due to damaging the motor unit as a result of a collision with the guide carriage!**

When setting the OPEN gate position, the guide carriage must not be driven to the end position at maximum speed!

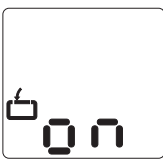
- Carefully drive the gate to the OPEN position at low speed.

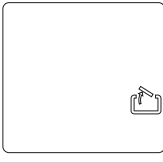

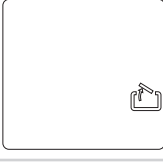

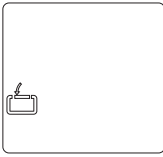
#### Quick programming

##### 1. Programming the gate position OPEN









Controller is in operating mode.	
 P > 3 sec. < 10 sec.: Start of quick programming.	
 + Drive gate to OPEN position.	
 P Save OPEN gate position.	

## Quick programming

### 2. Programming the gate position CLOSED











 Drive gate to CLOSED position.	
 Save gate position CLOSED.	

### 3. Programming the remote control (XB72)

 Only with bi-linked version: Actuate the programming button on the hand-held transmitter.	
 Actuate hand-held transmitter.	
 Release hand-held transmitter.	
 Save remote control. End of quick programming.	
Controller is in operating mode.	

## 4.6 Function test

### 4.6.1 Checking the drive functions

1.	Controller is in operating mode.	
2.	 The gate must open and drive to the saved gate position OPEN.	
3.	 The gate must close and drive to the saved gate position CLOSED.	
4.	 The drive system must drive the gate in the OPEN or CLOSED direction.	
5.	 The drive system must stop.	
6.	 The drive system runs in the opposite direction.	

### 4.6.2 Teaching run for the drive force

The drive system learns the maximum drive force required during the first six runs after setting the gate positions.

- Run the drive system (with gate engaged) from the OPEN gate position to the CLOSED gate position and back three times without interruption.

### 4.6.3 Checking the automatic cut-out

#### **WARNING!**

##### **Risk of injury due to operation without automatic cut-out!**

The drive is equipped with an automatic cut-out for personal protection.

Only ever operate the product if the correct function of the automatic cut-out is guaranteed.

- Test the automatic cut-out with OPEN and CLOSE.
- Commission a qualified specialist with testing the driving power using a force tester designed for this purpose.

#### **Automatic cut-out OPEN**

- Load the gate in the centre of the lower edge with a mass of 20 kg during the gate run:  
The gate must stop immediately.

#### **Automatic cut-out CLOSE**

- Place a 50 mm tall obstacle on the ground.
- Drive the gate over the obstacle:  
The drive system must stop and reverse upon encountering the obstacle.

The settings for the drive forces OPEN and CLOSE are retained if the mains power is interrupted.

Only after a reset are the parameters restored to the factory settings.

→ "Level 1, Menu 8 - RESET"

### 4.6.4 Checking the photocell

#### **Photocell**

- Check all photocells individually by triggering the function.
- Check all connected photocells directly in front of the CLOSED gate position.

#### **Peculiarities with gate frame photocells**

- The function of a connected frame photocell must be realised above the installation position. Beneath the installation position, the function is suppressed by the controller.
- If multiple photocells are connected, all photocells react in the same way with a possible frame photocell.

### 4.6.5 Check the closing edge safeguard

- Check all closing edges individually by triggering the function.

### 4.6.6 Check the personnel door contact

- Open the personnel door.
- Move the gate: The drive system is not permitted to move.

## 4.7 Marantec Service Access (MSA)

The MSA prevents unauthorised persons from changing safety-relevant values.

The following functions shall be programmed exclusively by qualified specialist personnel with the help of the MSA:

- Level 2 (drive settings)
- Level 3 (automatic closing)
- Level 6 (variable speeds)
- Level 8 (system settings)

The drive stores the customer ID, which can be found on the rear of the MSA.

### 4.7.1 Inserting the MSA

#### 4.7.1 / 1

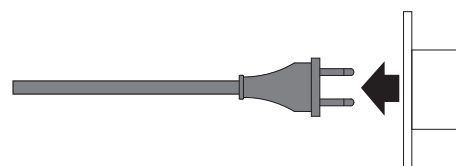

#### 4.7.1 / 2

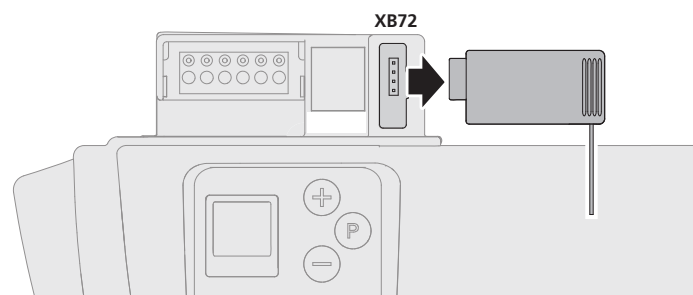

#### 4.7.1 / 3

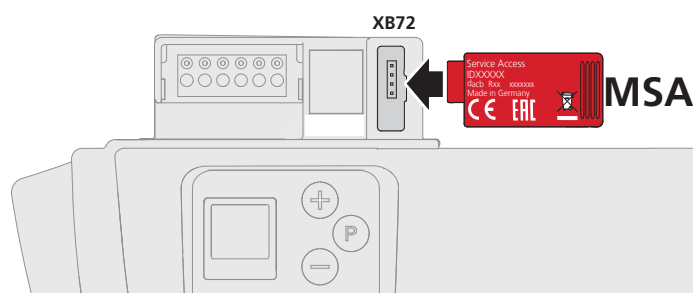

#### 4.7.1 / 4

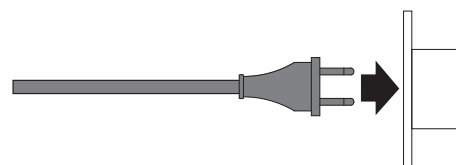

## 4.7.2 Removing the MSA

4.7.2 / 1

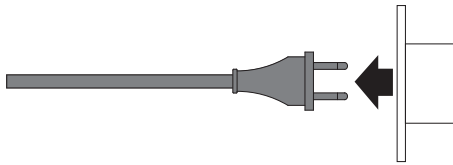

4.7.2 / 2

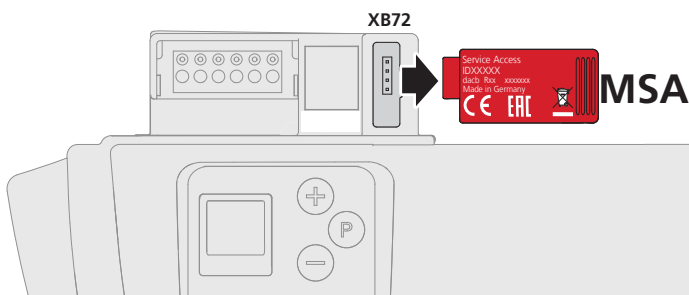

4.7.2 / 3

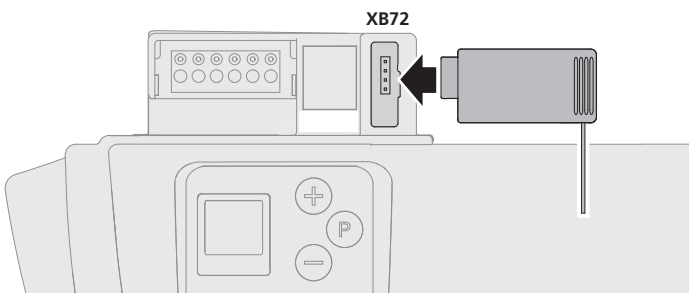

4.7.2 / 4

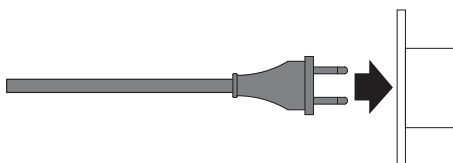

## 4.8 Special programming

### WARNING!

#### **Risk of injury due to incorrect gate force setting!**

In order to guarantee personal protection, the gate forces must comply with specified limit values. If the parameters are changed, these limit values could be exceeded. After changing the settings, it is therefore necessary to check the gate forces to guarantee safe operation.

- Test the automatic cut-out.
- "4.6.3 Checking the automatic cut-out"

After a reset, all parameters are reset to the factory settings. Connected and functional safety elements are redetected after the reset.

Connected further accessories must be reprogrammed after a reset.

In order to guarantee faultless operation of the controller:

- Reprogram all desired functions.
- Teach the remote control again.
- Run the drive system into the gate position OPEN and CLOSED once.

A connected photocell is automatically detected by the controller as soon as the power supply is connected. The photocell can be retrospectively reprogrammed.











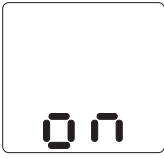

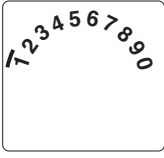



Unwanted photocells must be disconnected before the power supply is connected, otherwise the controller will detect them.

→ "3.4.5 2-wire photocell connection (XB03)"

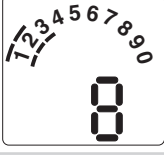

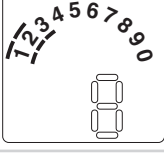

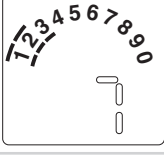
✓ It is necessary to perform a functional test after changes in programming mode.

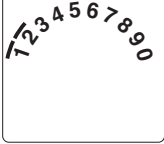
→ "4.6 Function test"

### 4.8.1 Programming the special functions

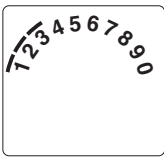
Programming sequence		
1.	Controller is in operating mode.	
2.	 P > 10 sec.: Start of programming the expanded drive functions. Display of the levels.	
3.	  Selection of the desired level (example level 2).	
4.	 Confirmation of the desired level. Display of the first menu and the set parameter.	
5.	  Selection of the desired menu (example menu 3).	
6.	 Confirmation of the desired menu. Display of the set parameter.	
7.	  Change of the parameter.	
8.	 Saving the parameter. The controller switch to the levels view	

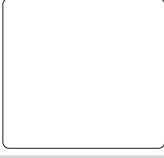
### Programming sequence

	Selection of the next desired level.	
	Continuation of programming.	
or		
9.	 P > 5 sec.: End of programming. All changed parameters are saved.	
	Controller is in operating mode.	

### 4.8.2 Overview of the special functions

Level	Menu
1 Basic functions	3 Intermediate position OPEN
	4 Intermediate position CLOSED
	7 Relay output
	8 RESET
2 Drive settings	1 Required drive force OPEN
	2 Required drive force CLOSE
	3 Automatic cut-out OPEN
	4 Automatic cut-out CLOSE
3 Automatic closing	1 Automatic closing
	3 Opening time
	4 Pre-warning time
	5 Start-up warning
	7 Signal light
4 Radio programming	2 Intermediate position OPEN
	3 Intermediate position CLOSED
	4 OPEN
	5 CLOSED
	8 Drive lighting ON / OFF or relay output
5 Special functions	1 Programmable pulse input
	3 Programmable input
	4 Lighting time
	5 Manual programming device
	7 Battery-back-up



Level	Menu
6 Variable speed	1 Speed OPEN
	2 Speed soft running OPEN
	3 Soft running position OPEN
	4 Speed CLOSE
	5 Speed smart running CLOSE
	6 Speed soft running CLOSE
	7 Smart running position CLOSE
	8 Soft running position CLOSE
	9 Soft start time OPEN
	10 Soft start time CLOSE
7 Service and maintenance	1 Gate cycle counter
	2 Maintenance counter
	3 Maintenance interval
	8 Reset service and maintenance
	9 Fault indication
8 System settings	1 Photocell
	2 Closing edge safety device
	3 Automatic cut-out function
	4 Operating modes
	5 Function of the direction command device
	6 Function of the pulse command device
	7 Force relief in the GATE CLOSED position (back-jump)
	8 Direction of rotation
	10 Position of the frame photocell

### 4.8.3 Contents of the special functions

#### Level 1 – Basic functions

##### Menu 3 – Intermediate position OPEN

Setting with button + (OPEN) and – (CLOSE).  
Closing function is possible with automatic closing.  
It is only possible to use the most recently programmed intermediate position.

##### Menu 4 – Intermediate position CLOSED

Setting with button + (OPEN) and – (CLOSE).  
Closing function is not possible with automatic closing.  
It is only possible to use the most recently programmed intermediate position.

##### Menu 7 – Relay output (XH19/XH79)

(only programmable with expansion module EP 161 or EP 163 connected)

1	 Signal light (available / not available) → "Level 3, Menu 7 - Signal light"
2	Gate position OPEN
3	Gate position CLOSED
4	Intermediate position OPEN
5	Intermediate position CLOSED
6	Drive system starts (wipe pulse 1 second)
7	Fault
8	Lighting time → "Level 5, Menu 4 - Lighting time"
9	Locking release (drive system running)
10	Locking release (drive system stationary)
11	Lock release (drive system starts / wipe pulse 3 seconds)
12	Anti-opening mechanism
13	Radio remote control (relay switches for the duration of the pulse)
14	Test pulse for closing edge safety device (relay issues a test pulse and switches for 300 ms)

### Level 1 – Basic functions

#### Menu 8 – RESET

The drive system can be reset to the factory settings. After a reset of the control or replacement of the control box, all desired individual settings must be input again.

1	 No reset
2	Reset control (Connected modules (bus modules, remote control) must be reset separately)
3	Reset remote control (telegrams are deleted)
4	Reset expansion automatic closing → "Level 3 - Automatic closing"
5	Reset only expanded drive functions (apart from gate position OPEN/CLOSE and remote control pulse)
6	Reset safety elements (photocell / hold circuit)
7	Reset bus modules (connected bus modules are taught)

### Level 2 – Drive settings

The following menus and functions are only accessible for qualified specialist personnel. The MSA is required for enabling the function.  
→ "4.7 Marantec Service Access (MSA)"

#### Menu 1 – Required drive force OPEN

Sensitivity in stages from 1 - 16  
(the higher the stage, the higher the driving force).  
 8

#### Menu 2 – Required drive force CLOSE

Sensitivity in stages from 1 - 16  
(the higher the stage, the higher the driving force).  
 8

#### Menu 3 – Automatic cut-out OPEN

Sensitivity in stages from 1(OFF) - 16  
(the lower the stage, the more sensitive the automatic cut-out).  
 12

#### Menu 4 – Automatic cut-out CLOSE

Sensitivity in stages from 1(OFF) - 16  
(the lower the stage, the more sensitive the automatic cut-out).  
 8

### Level 3 – Automatic closing

The following menus and functions are only accessible for qualified specialist personnel. The MSA is required for enabling the function.  
→ "4.7 Marantec Service Access (MSA)"

#### Menu 1 – Automatic closing

With activated automatic closing, the relay output (level 1 / menu 7) can be reprogrammed if necessary (not with visible and programmable track controls expansion module connected).

1	 Deactivated	
2	Opening time 15 / pre-warning time 5	Extension of the opening time only through pulsing (Button, hand-held transmitter).
3	Opening time 30 / Pre-warning time 5	
4	Opening time 60 / Pre-warning time 8	
5	Opening time 15 / Pre-warning time 5	Cancel the opening time after passing the photocell.
6	Opening time 30 / Pre-warning time 5	
7	Opening time 60 / Pre-warning time 8	
8	Opening time endless / Pre-warning time 3	Close after passing the photocell / closing prevention.

#### Menu 3 – Opening time

2 – 250 seconds.  
 Depending on level 3, menu 1

#### Menu 4 – Pre-warning time

1 – 70 seconds.  
 Depending on level 3, menu 1

#### Menu 5 – Start-up warning

0 – 7 seconds.  
 0

#### Menu 7 – Signal light

The setting acts on all relays that were programmed ex works or retrospectively to the "Signal light" parameter.

1	 Gate movement / warning: flashing Gate standstill: Off (energy saving)
2	Gate movement / warning: illuminated Gate standstill: Off (energy saving)
3	Gate movement / warning: flashing Gate standstill: flashing
4	Gate movement / warning: illuminated Gate standstill: illuminated
5	Gate movement / warning: flashing Gate standstill: illuminated
6	Gate movement / warning: illuminated Gate standstill: flashing

#### Level 4 – Radio programming

##### Menu 2 – Intermediate position OPEN

Parameter and hand-held transmitter display flashing  
-> Press hand-held transmitter button -> Hand-held transmitter display lights up briefly -> The function has been taught.

##### Menu 3 – Intermediate position CLOSED

Parameter and hand-held transmitter display flashing  
-> Press hand-held transmitter button -> Hand-held transmitter display lights up briefly -> The function has been taught.

##### Menu 4 – OPEN

Parameter and hand-held transmitter display flashing  
-> Press hand-held transmitter button -> Hand-held transmitter display lights up briefly -> The function has been taught.

##### Menu 5 – CLOSED

Parameter and hand-held transmitter display flashing  
-> Press hand-held transmitter button -> Hand-held transmitter display lights up briefly -> The function has been taught.

##### Menu 8 – Drive lighting ON / OFF

Parameter and hand-held transmitter display flashing  
-> Press hand-held transmitter button -> Hand-held transmitter display lights up briefly -> The function has been taught.

Relay output:  
The parameter "radio remote control" must be programmed.  
-> "Level 1, Menu 7 - Relay output"

#### Level 5 – Special functions

Programming the special functions is dependent on the connection XB03.

-> "3.4.5 2-wire photocell connection (XB03)"

##### Menu 1 – Programmable pulse input (terminal 1/2)

1	 Pulse (only NO)
2	Closing prevention (only NO)
3	Stops and reverses (only OPEN direction - only NC)
4	Stops and reverses (only CLOSE direction - only NO)
5	OPEN pulse (induction loop - only NO)
6	Premature closing through actuation of button or hand-held transmitter > 2 seconds (only Multi-Bit)
7	Pulse (only NO) with permanent power supply 24 V DC / max. 50 mA

##### Menu 3 – Programmable input (XW81)

1	 Pulse (only NO)
2	Pulse RC (only NO)
3	Closing prevention (only NO)
4	Stops and reverses (only OPEN direction - only NC)
5	Stops and reverses (only CLOSE direction - only NO)
6	OPEN pulse (only NO)
7	Stop (only NC)
8	Premature closing through actuation of button or hand-held transmitter > 2 seconds (only Multi-Bit)
9	Automatic closing ON/ OFF

##### Menu 4 – Lighting time

2 – 250 seconds.  
 3.0 (180 seconds)

##### Menu 5 – Manual programming device

1	 Operating and programming possible
2	Only operating possible

##### Menu 7 – Battery-back-up

1	 Battery-back-up deactivated
2	Battery-back-up active

### Level 6 - Variable speed

The following menus and functions are only accessible for qualified specialist personnel.

The MSA is required for enabling the function.

→ "4.7 Marantec Service Access (MSA)"

#### Menu 1 - Speed OPEN

Stages of speed soft running OPEN up to 16.

 16

#### Menu 2 - Speed soft running OPEN

Stages from 1 to speed OPEN.

 8

#### Menu 3 - Soft running position OPEN

Setting with button + (OPEN) and - (CLOSE).

#### Menu 4 - Speed CLOSE

Stages of speed soft running CLOSE up to 16.

 8

#### Menu 5 - Speed smart running CLOSE

Stages of speed soft running CLOSE up to speed CLOSE.

 8

#### Menu 6 - Speed soft running CLOSE

Stages from 1 to speed CLOSE.

 8

#### Menu 7 - Smart running position CLOSE

Setting with button + (OPEN) and - (CLOSE).

#### Menu 8 - Soft running position CLOSE

Setting with button + (OPEN) and - (CLOSE).

#### Menu 9 - Soft start time OPEN

1	 1 second
2	2 seconds
3	3 seconds
4	6 seconds

#### Menu 10 - Soft start time CLOSE

1	 1 second
2	2 seconds
3	3 seconds
4	6 seconds

### Level 7 - Service and maintenance

#### Menu 1 - Gate cycle counter

Six-digit display of gate actuations up to 999999.  
Digits in turn until the dot is displayed, then repeat.

#### Menu 2 - Maintenance counter

Five-digit display of the remaining gate actuations until the maintenance display.  
Digits in turn until the dot is displayed, then repeat.

#### Menu 3 - Maintenance interval

Setting the number of gate actuations from which the required maintenance is displayed.

1	 OFF
2	100
3	500
4	1,000
5	4,000
6	5,000
7	6,000
8	7,000
9	8,000
10	9,000
11	10,000
12	15,000
13	20,000
14	30,000
15	40,000
16	50,000



#### Menu 8 - Reset service and maintenance

The error memory is reset here for service, diagnostic and maintenance work.

1	 No reset
2	Reset error memory

#### Menu 9 - Fault indication

Display of the current error message.  
(max. 16 error displays possible).

	Display of the previous error / Navigation through the error list
	Navigation through the error list

### Level 8 – System settings

The following menus and functions are only accessible for qualified specialist personnel.

The MSA is required for enabling the function.

→ "4.7 Marantec Service Access (MSA)"

Gate reversal brief:

The drive system briefly moves the gate in the opposite direction to release an obstacle.

Gate reversal extended:

The drive system moves the gate to the OPEN gate position.

#### Menu 1 – Photocell

1	 Operation without photocell
2	2-wire photocell (Connection XB03 - terminal 70/71), Gate movement CLOSE: Gate reversal extended
3	External photocell (Connection XB03 - terminal 70/71), Gate movement CLOSE: Gate reversal extended

#### Menu 2 – Closing edge safety device

Gate movement OPEN changes the function of an optionally connected expansion module EM 183 OPEN.

1	 Gate movement OPEN: Gate reversal brief Gate movement CLOSE: Gate reversal brief
2	Gate movement OPEN: Gate reversal brief Gate movement CLOSE: Gate reversal extended
3	Gate movement OPEN: Gate reversal extended Gate movement CLOSE: Gate reversal brief
4	Gate movement OPEN: Gate reversal extended Gate movement CLOSE: Gate reversal extended

#### Menu 3 – Automatic cut-out function

1	 Gate movement OPEN: Gate stops Gate movement CLOSE: Gate reversal brief
2	Gate movement OPEN: Gate reversal brief Gate movement CLOSE: Gate reversal brief
3	Gate movement OPEN: Gate stops Gate movement CLOSE: Gate reversal extended
4	Gate movement OPEN: Gate reversal extended Gate movement CLOSE: Gate reversal extended
5	Gate movement OPEN: Gate reversal brief Gate movement CLOSE: Gate reversal extended

#### Menu 4 – Operating modes

1	Gate movement OPEN: Dead man Gate movement CLOSE: Dead man
2	Gate movement OPEN: Self-retaining Gate movement CLOSE: Dead man
3	Gate movement OPEN: Dead man Gate movement CLOSE: Self-retaining
4	 Gate movement OPEN: Self-retaining Gate movement CLOSE: Self-retaining

### Level 8 – System settings

The following menus and functions are only accessible for qualified specialist personnel.

The MSA is required for enabling the function.

→ "4.7 Marantec Service Access (MSA)"

#### Menu 5 – Function of the direction command device

1	Direction command device not active: The direction command devices only trigger a command with a stationary gate.
2	 Direction command device only STOP: A running gate is stopped by every direction command device.

#### Menu 6 – Function of the pulse command device

1	Pulse command device not active: The pulse command devices only trigger a command with a stationary gate.
2	Pulse command device only STOP, subsequently standard sequence: A running gate is stopped by every pulse command device. A subsequent command starts the drive system in the opposite direction (OPEN - STOP - CLOSE - STOP - OPEN).
3	 Pulse command device only STOP, subsequently standard sequence: A running gate is stopped by every pulse command device. A subsequent command starts the drive system in the opposite direction (OPEN - STOP - CLOSE - STOP - OPEN). With automatic closing, no STOP in the OPEN direction.

#### Menu 7 – Force relief in the GATE CLOSED position (back-jump)

1	 not active
2	minimal
3	short
4	medium
5	long

#### Menu 8 – Direction of rotation

1	 Standard
2	Reversal of rotational direction

#### Menu 10 – Position of the frame photocell

The position of the frame photocell can be manually set if necessary.

Setting with button + (OPEN) and - (CLOSE).

## 5. Operation

### 5.1 Safety instructions for operation

#### WARNING!

##### **Danger due to a failure to observe the operating instructions!**

This chapter contains important information for the safe operation of the product.

- Read this chapter through carefully before operation.
- Follow the safety instructions.
- Use the product as described.

- The controller or hand-held transmitter shall only be operated when no persons or objects are inside the range of movement of the gate.
- The controller and hand-held transmitter must not be used by children or unauthorised persons.
- The hand-held transmitter must not be inadvertently actuated (e. g. in the trouser pocket).
- No obstacle shall be present in the path of the gate and hand cable. Otherwise the hand cable may become trapped during gate movements, resulting in damage (e. g. with roof rack systems).

### 5.2 Remote controls

-  Refer to the associated documentation for operation of the control unit with remote controls.

### 5.3 Release

#### WARNING!

##### **Risk of injury due to uncontrolled gate movements!**

Uncontrolled gate movements may arise when actuating the unlocking, e.g. if the gate springs are weak or broken, or the gate is not balanced.

- Move the gate cautiously in the unlocked condition and only at moderate speed!

#### NOTICE

##### **Risk of material damage due to uncontrolled gate movements!**

When opening the gate by hand, the guide carriage can collide with the rail stop.

- Move the gate cautiously in the unlocked condition and only at moderate speed!

5.3 / 1

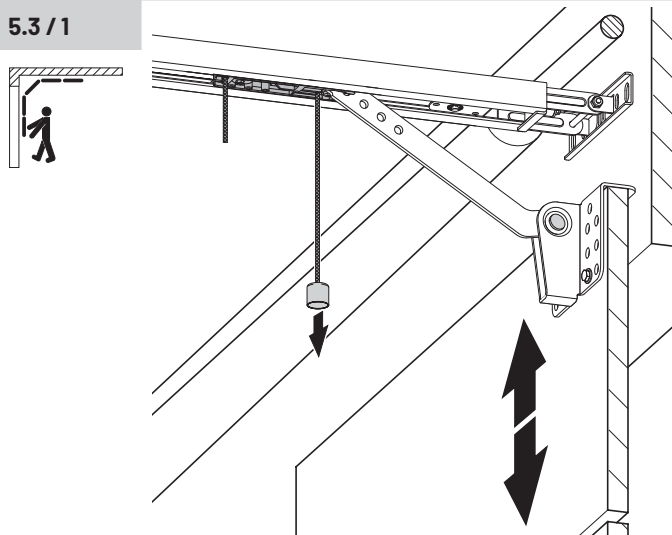

5.3 / 2

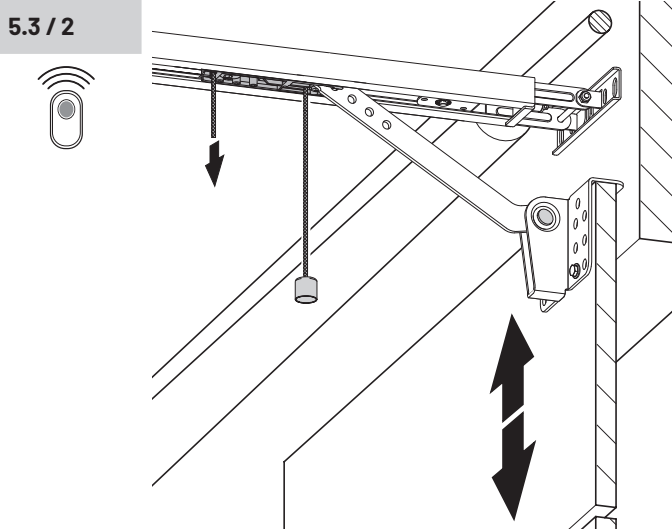

## 6. Care

### WARNING!

#### **Risk of fatal injuries due to electric shocks!**

Contact with live parts can lead to electric shock, burns and death.

- Ensure that the power supply is and remains disconnected throughout any cleaning work.

### NOTICE

#### **Damage resulting from incorrect operation!**

When cleaning the drive, never use:  
direct water jets, high pressure cleaners, acids or alkaline solutions.

- Use a soft, non-linting cloth for cleaning.

If particularly dirty, the housing can be cleaned using a mild detergent.

- Clean the outside of the housing using a damp cloth.

## 7. Maintenance

### 7.1 Maintenance work by the operator

Damage or wear to a gate system may only be rectified by qualified specialist personnel.

To ensure fault-free operation, the gate system must be inspected regularly and, if necessary, be repaired. Before starting work on the gate system, the drive system must always be disconnected from the power supply.

- Check once a month that the operator system reverses when the gate touches an obstacle. To check this, place an obstacle, 50 mm in height, in the path of the gate in the direction of travel.
- Check the settings of the automatic cut-out in the OPEN and CLOSE directions.
- "4.6.3 Checking the automatic cut-out"
- Check all the moving parts of the gate system and gate operator system.
- Check the gate system for signs of damage or wear and tear.
- Move the gate manually to check that the gate travels easily and smoothly.
- Check all connection lines for damage.  
For safety reasons, if the power supply cable is damaged it must be replaced by the manufacturer or the manufacturer's customer service department, or by a similarly qualified person.

### 7.2 Maintenance by qualified specialist personnel

Power-operated windows, doors and gates must be inspected by qualified personnel whenever necessary, but at least once a year (written inspection records must be kept).

Before starting work on the gate system, the drive system must always be disconnected from the power supply.

- Test the driving power with a force tester designed for this purpose.
- Replace any damaged or worn parts.

## 8. Disassembly

Disassembly by qualified specialist personnel only.  
→ "1.2.2 Specialist personnel"

### WARNING!

#### Risk of fatal injuries due to electric shocks!

Contact with live parts can lead to electric shock, burns and death.

- Ensure that the power supply is and remains disconnected throughout disassembly.

### WARNING!

#### Risk of injury due to incorrect use!

Size and weight of the product require extensive force during disassembly. If the product drops, this may result in serious injuries.

- Secure the drive system against falling before disassembly.
- Comply with all applicable occupational health and safety regulations.

Disassembly is performed in reverse order to assembly.  
→ "3. Installation"

## 9. Disposal

Disposal by qualified specialist personnel only.  
→ "1.2.2 Specialist personnel"

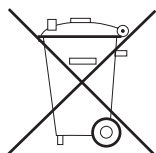

Do not dispose of old equipment or batteries with normal household waste!

- Dispose of old equipment at a collection centre for electronic scrap or via your specialist dealer.
- Dispose of used batteries in a recyclables collection container for used batteries or via your specialist dealer.
- Dispose of the packaging materials in a collection container for paper, cardboard and plastic.

## 10. Troubleshooting

### Faults without the error message display

#### LCD display has no display and does not light up.

Voltage missing.

- Check whether mains voltage is present.
- Check current connection.

Thermal contactor in mains transformer has triggered.

- Leave the mains transformer to cool down.

Controller unit defective.

- Have the drive system checked.

#### No response after pulsing.

Connection terminals for "Pulse" button bypassed, e.g. through line short-circuit or flat terminal.

- Possibly test-disconnect wired key switch or internal push-button from the controller unit: Unplug cable from socket XB01, insert short-circuit plug and search for wiring fault.
- "3.4.5 2-wire photocell connection (XB03)"

#### No response after pulsing by hand-held transmitter.

Module receiver not plugged in.

- Connect module receiver with controller unit.
- "3.5 Completing the installation"

Hand-held transmitter coding does not match receiver coding.

- Reactivate hand-held transmitter.
- "4.4 Factory settings"

Hand-held transmitter battery empty.

- Insert new battery.

Radio operation deactivated ("external button" symbol flashes).

- Press the + (OPEN) or - (CLOSE) button on the drive to reactivate the radio.

Hand-held transmitter or controller electronics or module receiver defective.

- Have all 3 components checked.

#### Drive system reverses with interruption to frame photocell.

Programming was not performed correctly. Frame photocell was not identified correctly.

- Manually set the position of the frame photocell.
- "Level 8, Menu 10 - Position of the frame photocell"



## Faults without the error message display

### Low or no range.

Hand-held transmitter defective.

- Check hand-held transmitter, replace if necessary.

Antenna defective or installed incorrectly.

- Check / replace antenna.
- Lay antenna to the lintel or feed out of the garage, if nec. install outside antenna.

Faults on frequency band used.

- Switch to alternative frequency.

### Drive lighting not working.

Bulb defective.

- Replace LED.

### With further faults.

- Observe error message (see LCD display).
- Have article no., production no. and version to hand (see type plate) for any queries.
- Reset and re-commissioning in accordance with the operating manual.

## Faults with error message display

The display shows detected faults with an error number (example error number 7). The controller switches to the message mode.

In operating mode, pressing the P button

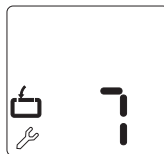

### Error number 7

After 120 seconds without pressing a button, programming mode switches off automatically.

- Restart the programming procedure.

### Error number 9

Speed sensor pulse not available, drive system blocked.

- Have the drive system checked.

## Faults with error message display

### Error number 10

Gate running sluggish or gate blocked.

- Re-establish gate movement.

Maximum drive force set too low.

- Have the maximum drive force checked by qualified specialist personnel using an appropriate force tester.

→ "Level 2, Menu 1 - Required drive force OPEN"

→ "Level 2, Menu 2 - Required drive force CLOSE"

### Error number 11

Run-time limiting.

- Have the drive system checked.

### Error number 15

Photocell interrupted or defective.

- Remove obstacle or have photocell checked.

Photocell programmed but not connected.

- Deactivate or connect photocell.

### Error number 16

Current sensor for automatic cut-out defective.

- Have motor unit checked.

### Error number 26

Undervoltage. Drive system overloaded when drive force set to stage 16 (maximum).

- Have external voltage supply checked.

### Error number 28

Gate running sluggish, irregular or gate blocked.

- Check gate running and re-establish gate movement.

Automatic cut-out setting is too sensitive.

- Have automatic cut-out checked by specialist dealer.

→ "Level 2, Menu 3 - Automatic cut-out OPEN"

→ "Level 2, Menu 4 - Automatic cut-out CLOSE"

## Faults with error message display

### Error number 30

MS-Bus error.

- Perform reset of the MS Bus modules.
- "Level 1, Menu 8 - RESET"
- Have connected BUS modules checked.

### Error number 33

Overtemperature due to overheating.

- Leave the drive system to cool down.

### Error number 35

Electronics defective.

- Have the drive system checked.

### Error number 36

This error number can also be triggered by a connected expansion module.

Function of stop button programmed, but no stop button connected.

- Connect stop button.
- "3.4 Connection"
- If no stop button is available, complete "RESET safety elements" or "RESET BUS modules".
- "Level 1, Menu 8 - RESET"

### Error number 38

Anti-opening mechanism has triggered.

- Check gate for signs of a break-in.

### Error number 44

8K2 hold circuit of gate leaf has triggered.

- Check personnel door to make sure it is correctly closed.

### Error number 48

Gate running sluggish, irregular or gate blocked.

- Check gate running and re-establish gate movement.

Setting of gate positions CLOSED incorrect.

- Check gate positions OPEN and CLOSED and reset if necessary.
- Check gate.

## 11. Attachment

### 11.1 Manufacturer's declaration

#### Declaration of incorporation

within the context of EC Machinery Directive 2006/42/EC for integration with an incomplete machine in accordance with Annex II, Part 1B.

#### Declaration of conformity

within the context of Directives for Electromagnetic Compatibility 2014/30/EU and RoHS 2011/65/EU + 2015/863/EU + 2017/2102/EU.

#### Manufacturer:

Marantec Antriebs und Steuerungstechnik GmbH & Co. KG  
Remser Brook 11, 33428 Marienfeld, Germany

We hereby declare that the following listed product

Product designation: **Garage door drive**  
Type designation: **Comfort 390**  
Revision status: **R01, R10**

as an incomplete machine that is exclusively intended for installation in a door system and that has been developed, constructed, and manufactured in harmony with the following directives:

- Machinery Directive 2006/42/EC
- Electromagnetic Compatibility Directive 2014/30/EU
- RoHS Directive 2011/65/EU + 2015/863/EU + 2017/2102/EU

Furthermore, the requirements of the Low Voltage Directive 2014/35/EU as per Appendix I Part 1.5.1 of Machinery Directive 2006/42/EC are also satisfied.

Applied and referenced standards:

- EN 12453  
Safety in use of power operated doors: Requirements and test methods
- EN 12604  
Gates - Mechanical aspects: Requirements and test methods
- EN ISO 13849-1, PL "c", Cat. 2  
Safety of machinery - Safety-related parts of control systems - Part 1: General principles for design
- EN 60335-1  
Household and similar electrical appliances - Safety - Part 1: General requirements
- EN 60335-2-95  
Household and similar electrical appliances - Safety - Part 2-95: Particular requirements for drives for vertically moving garage doors for residential use
- EN 61000-6-2  
Electromagnetic Compatibility (EMC) - Part 6-2: Generic standards - Immunity standard for industrial environments
- EN 61000-6-3  
Electromagnetic Compatibility (EMC) - Part 6-3: Generic standards - Emission standard for residential, commercial and light industrial environments

The following requirements of EC Directive 2006/42/EC were complied with: General principles, No. 1.1.2, 1.1.3, 1.1.5, 1.1.6, 1.2.1, 1.2.2, 1.2.3, 1.2.6, 1.3.1, 1.3.4, 1.3.7, 1.3.8, 1.3.9, 1.4.1, 1.4.3, 1.5.1, 1.5.4, 1.5.6, 1.5.8, 1.5.14, 1.7.

Furthermore, we declare that the special technical documentation for this partly completed machine was prepared in accordance with Annex VII Part B and we undertake to supply these documents, in electronic form, to the national authorities in response to a duly reasoned request.

Authorised representative for preparation of the technical documentation:  
Marantec Antriebs- und Steuerungstechnik GmbH & Co. KG,  
Remser Brook 11. 33428 Marienfeld. Germany  
Tel. +49(5247) 705-0

Incomplete machines within the scope of EC Directive 2006/42/EC are only specified for integration with other machines or other incomplete machines or plants or connection with them to form a machine together with them within the context of the Directive indicated above. For this reason, this product may only be commissioned if it has been confirmed that the complete machine / system that it has been integrated with complies with the requirements of the above EC directives.

This declaration is void if changes are made to the product without our approval.



Marienfeld, 16.07.2020

M. Hörmann  
Managing Director



## 11.2 Radio conformity

The company  
Marantec Antriebs- und Steuerungstechnik GmbH & Co KG,  
hereby declares that the radio system model complies with  
directive 2014/53/EU.

1. Digital 168, Digital 179, Digital 921, Digital 941, Digital 991
2. Digital 382, Digital 384, Digital 392, Digital 564, Digital 572,  
Digital 663

The complete EU declaration of conformity text can be found at the following internet address:  
[marantec.group/conformity](http://marantec.group/conformity)

**Motor type plate**

Model (A) \_\_\_\_\_

Production month / year (B) \_\_\_\_\_

Art. No. Product (C) \_\_\_\_\_

Revision. (D) \_\_\_\_\_

Art. No. Sales product (E) \_\_\_\_\_

Serial number (F) \_\_\_\_\_

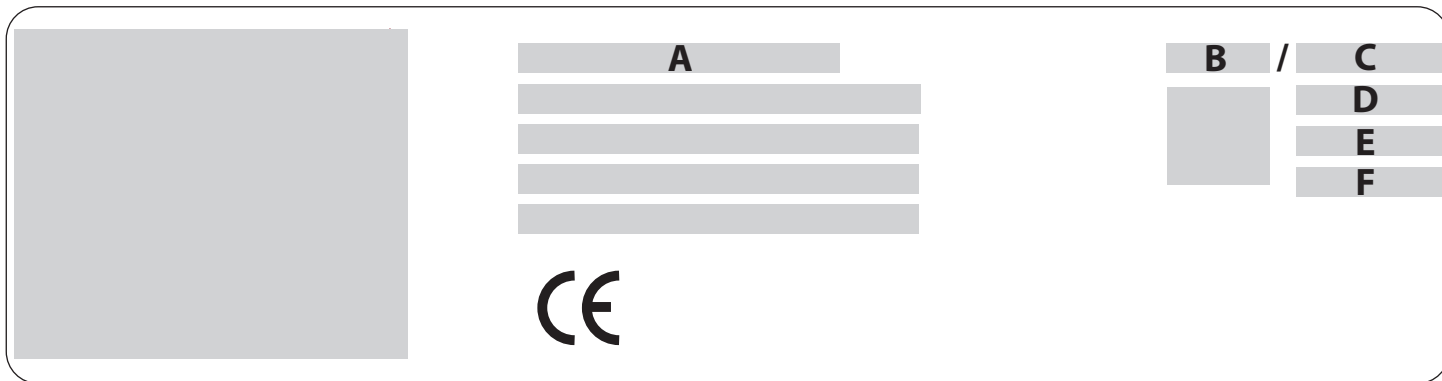

**Type plate on control unit**

Model (A) \_\_\_\_\_

Production month / year (B) \_\_\_\_\_

Revision. (C) \_\_\_\_\_

Art. No. Sales product (D) \_\_\_\_\_

Serial number (E) \_\_\_\_\_

