

Operating Instructions for Control Panel

RS 301K

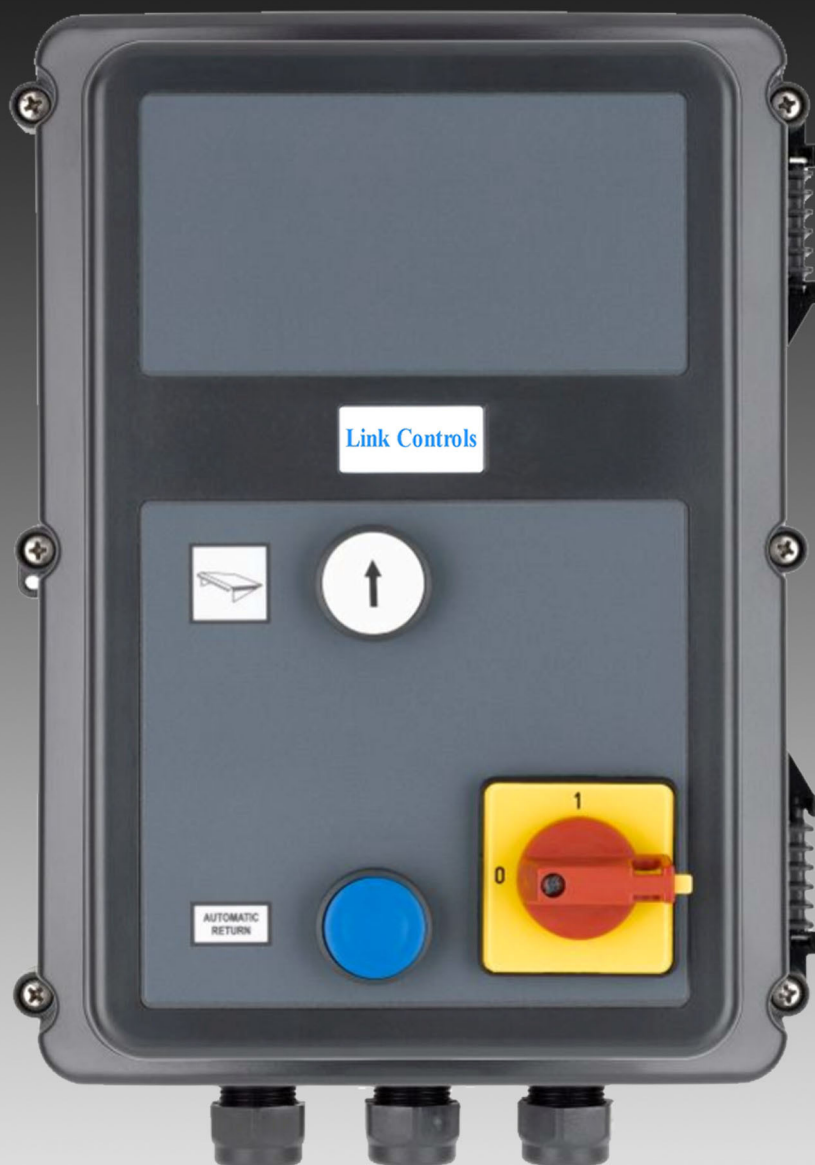

Warning : Please read these instructions fully before installation

GB 1 Contents

1	Contents	
2	Key to symbols	2
3	General safety instructions	2
4	Overview of products	4
5	Initial operation instructions	6
6	Initial operation	7
7	Functional description	11
8	Further functions	12
9	Option Display	13
10	Error messages and rectification	20
11	Technical Data	21

2 Key to symbols



Danger of personal injury!

The safety instructions must be observed!



Warning! Danger to property!

The safety instructions must be observed!



Information

Special information

OR Reference to other sources of information

3 General safety instructions

Guarantee

The function and safety of the equipment is only guaranteed if the warning and safety instructions included in these operating instructions are adhered to. MFZ Antriebe GmbH & Co. KG is not liable for any personal injury or damage to property that occurs as a result of the warning and safety instructions being disregarded.

Using the equipment for its intended purpose

The RS300K controls are designed only for dock levellers with hinged lip.

Target group

Only qualified and trained electricians may connect, program and service the controls.

Qualified and trained electricians meet the following requirements:

- knowledge of the general and specific safety and accident prevention regulations,
- knowledge of the relevant electrical regulations,
- trained in the use and care of appropriate safety equipment,
- capable of recognizing the dangers associated with electricity.

Instructions for installation and connection

- The controls must be disconnected from the electricity supply before carrying out electrical works. It must be ensured that the electricity supply remains disconnected during the works.
- Local protective regulations must be complied with.

Regulations and bases for testing

For connecting, programming and servicing, the following regulations must be observed (the list is not exhaustive).

Electromagnetic compatibility

- EN 50014-1 (radio disturbance, household appliances)
- EN 61000-3-2 (disturbances in supply system – harmonic currents)
- EN 61000-3-3 (disturbances in supply system – voltage fluctuations)
- EN 61000-6-2 (electromagnetic compatibility (EMC) – Part 6-2: Generic standards - immunity for industrial environments)
- EN 61000-6-3 (electromagnetic compatibility (EMC) – Part 6-2: Generic standards - emission standard for residential, commercial and light-industrial environments)

Machinery guidelines

- EN 1398 Dock levellers – safety requirements
- EN 60204-1 (safety of machinery, electrical equipment of machines, part 1: general requirements)
- EN 12100-1 (safety of machinery, basic concepts, general principles for design. Basic terminology, methodology)

Low voltage

- EN 60335-1 (household and similar electrical appliances - safety)

GB 4. Housing



Key

Mains switch

Button UP

Button Autoreturn

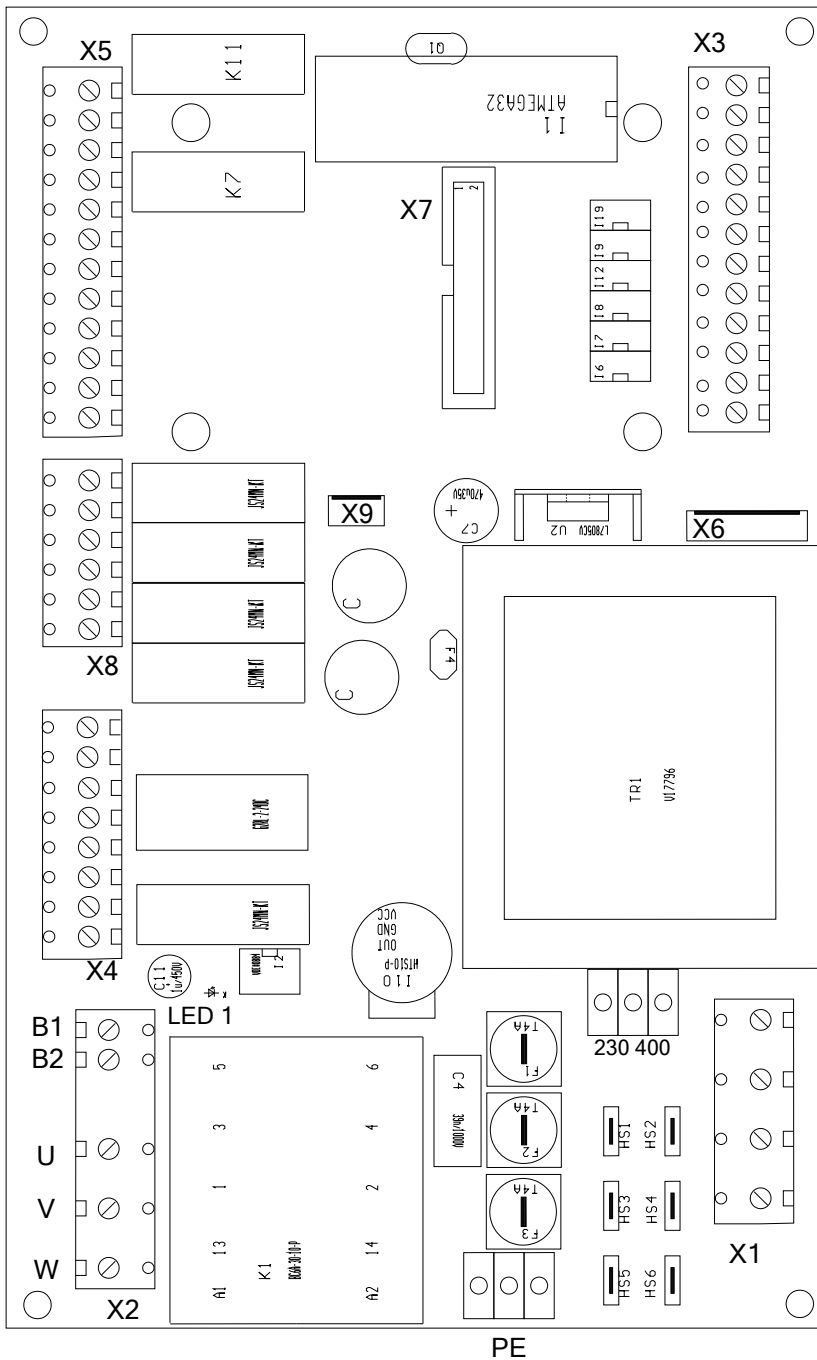

Key:

- X1: terminal block mains connection
- 230/400: terminal block adjustment of mains voltage
- PE: terminal block PE
- HS1 ... HS6: connection mains switch
- X2: terminal block hydraulic unit
- X3: terminal block command devices
- X4: terminal block tube motor and signal devices
- X5: terminal block valves and door
- X6: socket for internal push buttons
- X7: terminal block LCD
- X8: terminal block traffic lights
- X9: RS485 interface

- K1: Contactor
- F1 ... F3: overload protection hydraulic unit
- F4: Overload protection 24VDC

- J1: Jumper phase rotation

GB 5 Initial Operation – general instructions



Warning!

To guarantee that the equipment functions properly, the following points must be ensured:

- The dock leveller is installed and operational.
- The command and safety devices are installed and ready for operation.
- The control housing with the RS300K is installed.
- All motor connections are correct and on the motor side screwed tight.



Information:

For the installation of the dock leveller, the hydraulic unit and the command and safety devices, the relevant manufacturer's instructions are to be adhered to.

Mains connection



Danger!

To guarantee that the controls function properly, the following points must be ensured:

- The mains voltage must correspond to the voltage stated on the type plate.
- For a three-phase current, a clockwise rotating field is required.
- For a three-phase connection, only 3-way automatic circuit breakers (6A) may be used.



Warning!

After completion of the wiring and prior to switching on for the first time, the control should be checked that all motor connections are correct and screwed tight.

6 Initial Operation

Mains voltage adjustment



A wrong adjustment of the mains voltage can destroy the control.

Factory setting 400V

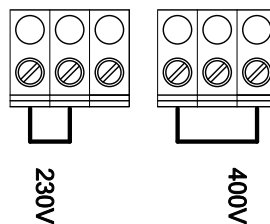

Mains supply X1

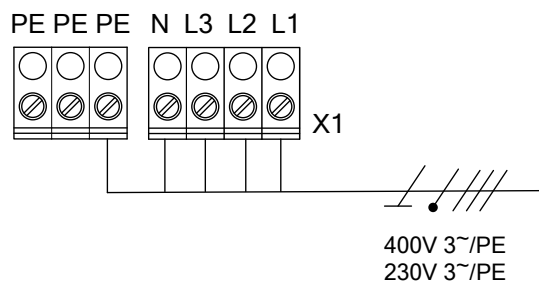

Mains switch

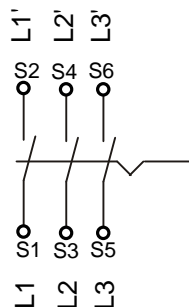

X2 Hydraulic unit



Note rotating field! LED 1 indicates whether a correct rotational field is applied. Release can only be undertaken with a clockwise rotating field.

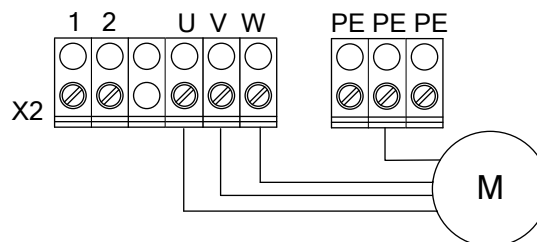

Emergency stop

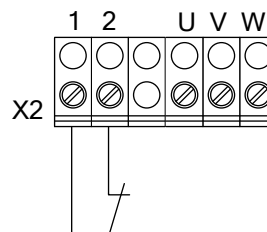

Valve:

Y1: stop valve 24 VDC 100%

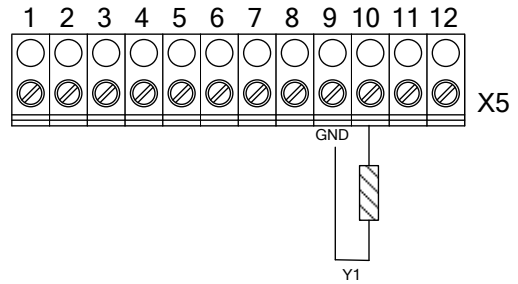

Connection to the door control

Door Release: Potential-free contact for locking the door system. The contact opens as soon as the dock leveller is not in the home position.

IMPULSE door close: During operation of the door leveller the contact is open. Only when the door leveller is in its home position is the contact closed

Interlock door - leveller: The control of the dock leveller is locked via a potential-free contact of the door system or a sensor. The polarity of the signal can be adjusted. The dock leveller can be operated only when a release of the door system is present. If during operation the door release is removed both traffic light will turn red.

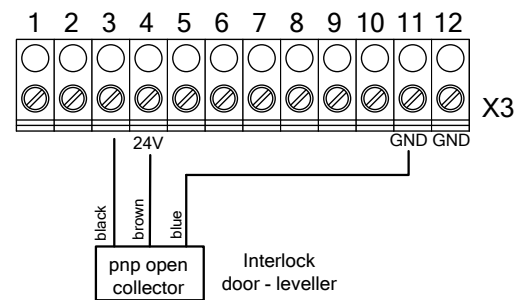
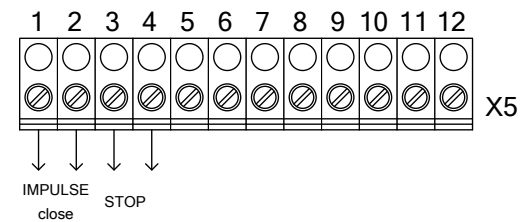
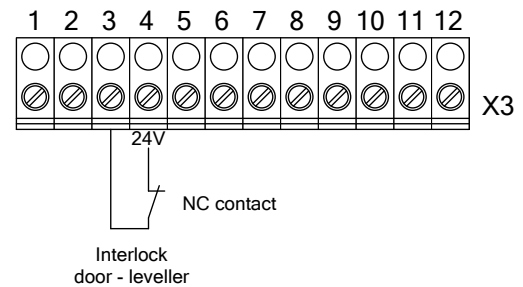

24 VDC for external units
max. 250 mA

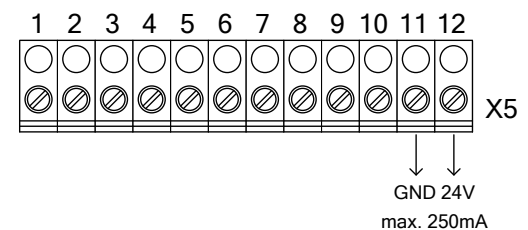

Traffic lights

- Inside green light (terminal 2)
- Inside red light (terminal 3)
- Outside green light (terminal 4)
- Outside red light (terminal 5)

Max. load
 24VDC max. 100mA
 230 VAC max. 40 W

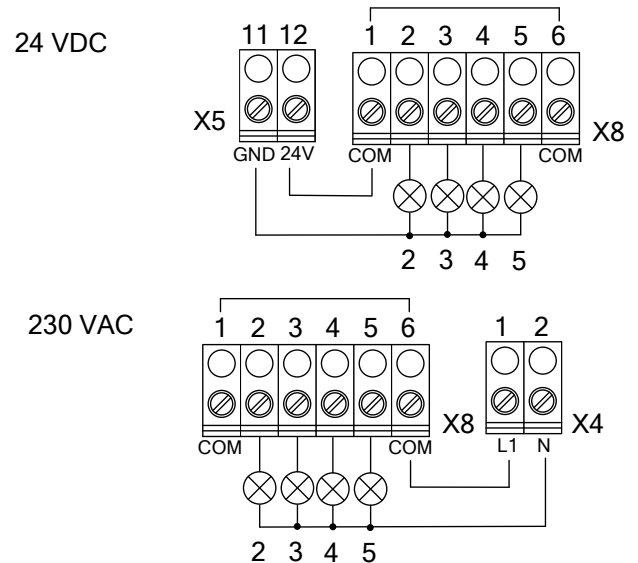

Tube motor for shelter door and 230 V Output

- The functions of the 230 VAC output have to be programmed via the display.
- MOD 1: Horn (standard)
 - MOD 2: Shelter fan
 - MOD 3: Loading lamp automatic
 - MOD 4: Loading lamp manual

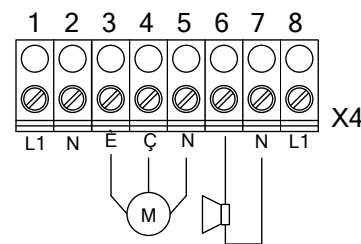

Vehicle detector:

Visual and audible collision safety applied by an approach sensor. If a vehicle in front of the gate activates the approach sensor a warning signal sounds and the lights outside red turns. Optionally, a door locking can be activated. This utility must be activated via the input function.

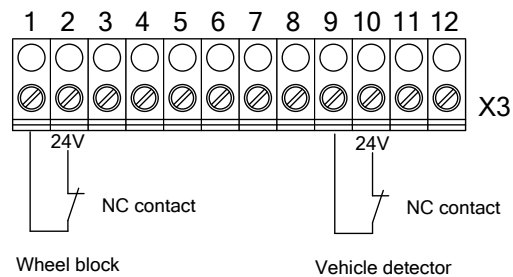

Wheel block:

The wheel block is used to secure the vehicle during the loading process. This utility must be activated via the input function.

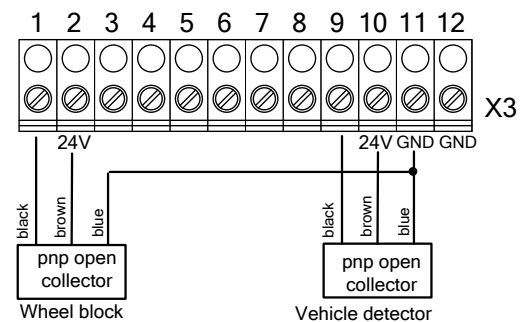

Free Connection

The operation of the free input can be selected via the input function to;

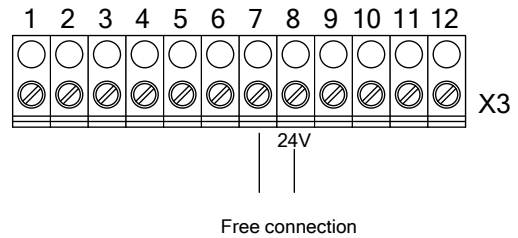

Traffic light confirmation: (NO contact)

The outer green traffic light turns on when the leveller is retracted, the wheel block is removed and the reset button has been pressed.

Safety fence: (NC Contact)

When the security fence is closed the dock leveller is locked.

Selector switch Shelter

Selector switch for the manual operation of the dock shelter.

Limit switch door leveller

The limit switch indicates that the dock leveller is in the home position.

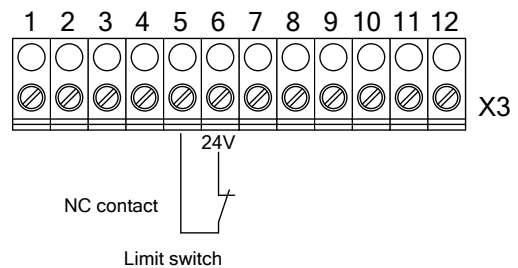

Cover button connections

All buttons are as No contact to close.

The cover LED (option) has the same function as the inner green light.

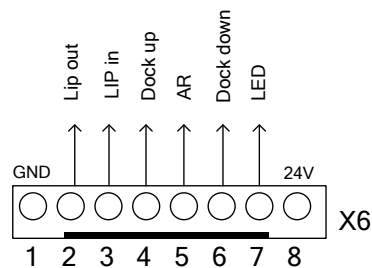

7 Functional description - Version hinged lip

7.1 Operation of the dock leveller

Raise the dock leveller with the button (dock UP) in dead-man operation mode. When the dock leveler reaches its upper end position the lip folds out automatically. The button should be released when the lip is completely folded out. The dock leveller descends automatically into the loading position (floating position).

With activated current detection, the upper position of the dock leveller is detected (unfolding of the lip) when lifting from the home position. If the upper end position is not reached within a minimum of 2 seconds, the control assumes that the lip is not completely unfolded and lowers the bridge back to its home position. When this position takes longer as 2 seconds to be reached, bridge lowers into the floating position.

7.2 Automatic return (AR)

Upon completion of the loading, the dock leveller is returned to its home position by pressing the AR button.

The AR function expires upon reaching the home position.

AR Version with current control (Standard)

- The dock leveller is raised until the upper end position is reached (this position is recognized through the current detection or by the time "AR RAISE 1").
To use the current detection, the time "AR RAISE 1" must be set at a high value.
- The leveller descends for the time "AR DROP 1"
- The leveller is raised again for the time "AR RAISE 2"
- The dock leveller descends automatically to the home position.
- After the interval "AR DROP 2" the leveller will continue with the program sequence.

AR Version timed function:

- The leveller raises for the time "AR RAISE 1"
- The leveller descends for the time "AR DROP 1"
- The leveller is raised again for the time "AR RAISE 2"
- The dock leveller descends automatically to the home position.
- After the interval "AR DROP 2" the leveller will continue with the program sequence.

GB 8 Further functions

8.1 Protection circuit

The control RS300K has an integrated protection circuit. If an emergency stop signal is received or the power is interrupted during the operation of the dock leveller, the stop circuit is switched off and locks the bridge in position.

Only after pressing the lift button can the bridge be moved into its home or floating position.

8.2 Detection of the phase rotation

The control RS300K has an integrated circuit for the detection of the phase rotation. The circuit checks to see if a clockwise rotating field has been applied before allowing a through connection. Where no clockwise rotating field is detected, then the contactor does not switch on. Furthermore, the circuit is protected against phase failure. Both of these errors are signaled by the LED 1.



The Detection of the phase rotation is possible only with the 400V mains supply. If the mains voltage 230 V 3Phasen should be used, then the Detection of the phase rotation must be deactivated with the Jumper 1.

8.3 Current detection in the folding lip version

The RS300 control has an integrated current measurement for the hydraulic unit. This measurement allows the detection of the upper end position of the dock leveller.

1. Recognition of the upper end position (unfolding of the lip) when lifting from the home position.

With activated current detection, the upper position of the dock leveller is detected (unfolding of the lip) when lifting from the home position. If the upper end position is not reached within a minimum of 2 seconds, the control assumes that the lip is not completely unfolded and lowers the bridge back to its home position. When this position takes longer than 2 seconds to be reached, the bridge lowers into the floating position.

2. Recognition of the upper end position during automatic return

Using "AR RAISE 1" the upper end position is recognized by the current detection or the set time. After detecting the upper limit position, the bridge lowers automatically to the home position.

9 Options DISPLAY

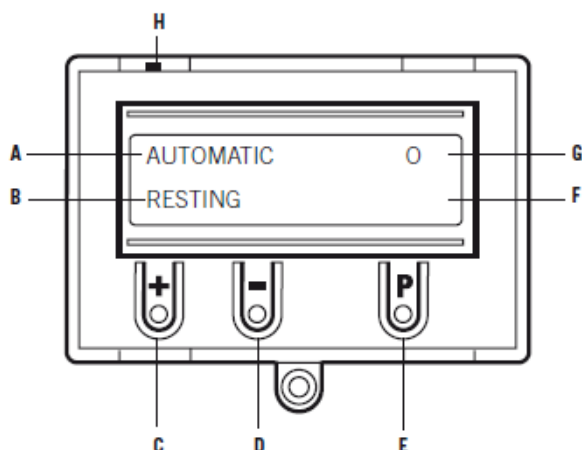

Key:

A: Operating mode / Diagnostic info

B: Parameters / Diagnostic info

C: + button

D: - button

E: P button

F: value / status

G: value / status

H: jumper

9.1 Operation mode of the LCD screen

With the LCD screen, the control is provided with 4 operation modes. If the Jumper H is pulled out, the key buttons +, - and P do not function. The display will continue to function.

Operation mode 1: AUTOMATIC

The dock is operated in the operation mode AUTOMATIC.

Display: - Notice about the running function
- Notice about the possible errors

Operation mode 2: INPUT

The values of the different parameters can be changed in the operation mode INPUT.

Display: - Notice about selected parameters
- Notice about the set values / status

Operation mode 3: DIAGNOSTIC

Controls specific to the leveller can be examined in the operation mode DIAGNOSTIC.

Display: - Notice about controls
- Notice about the control status

Operation mode 4: MAINTENANCE

MAINTENANCE mode allows the dock leveller to be operated via the installed housing buttons. The MAINTENANCE mode is only for commissioning. No floating positions are available.

Display: - Notice about the running functions.

9.2. Navigator

AUTOMATIC
STANDBY

P- > 1 sec.

INPUT	+ and -> 2 sec.	INPUT DEUTSCH	Scroll up through menu: + > 2 Sec Scroll down through menu: - > 2 sec. Select value: P > 1 sec. Increase value: + Decrease value: - Save value: P Return to INPUT mode: + and - > 1 sec.
		INPUT VALVE VER.: 1	
		INPUT AR RASIE 1 1.0	
		INPUT AR DROP 1 5.0	
		INPUT AR RAISE 2 6.0	
		INPUT AR DROP 2 2.0	
		INPUT TIME HYDR.: 50	
		INPUT TRAFFIC LIGHT MOD. 3	
		INPUT HORN/LIGHT: MOD 1	
		INPUT AUTORETURN: MOD 2	
		INPUT WHELL BLOCK: MOD 1	
		INPUT VEHICLE SENSOR MOD 1	
		INPUT SHELTER: MOD 1	
		INPUT SHELTER TIME: 1	
		INPUT RELEASE + / - MOD 1	
		INPUT RELEASE MOD 1	
		INPUT FREE 1 MOD 1	
		INPUT CURRENT CTRL 20%	
		INPUT DELAY TIME 0%	
		INPUT Y1 RAISE 0	

P- > 1 sec.

DIAGNOSIS	.	STOP CHAIN	ON	Scroll up through menu: + > 2 sec. Scroll down through menu: - > 2 sec. Return to AUTOMATIC mode: P Only queries are possible
		WHELL BLOCK	OFF	
		INTERLOCK	ON	
		HOME LS	OFF	
		ACKNOWLEDGE	OFF	
		VEHICLE SENSOR	OFF	
		LIP FORWARD	OFF	
		LIP BACK	OFF	
		RAISE	OFF	
		HOME	OFF	
		DROP	ON	
		CYCLE	OFF	

P- > 1 sec

MAINTENNACE	.	MANUAL OPERATION OF THE DOCK
		LIFT
		LOWER (AR)
		FORWARD
		BACK

P- > 1 sec

GB 9.3 Operating mode Automatic

Display	Meaning
AUTOMATIC STANDBY	The dock leveller is in initial position.
AUTOMATIC FLOATING	The dock leveller is in working position.
AUTOMATIC EMERGENCY STOP	The dock leveller is in the EMERGENCY STOPS status. For setting the leveller back into the initial position, the button leveller up must be pressed first and then the button automatic returns.
AUTOMATIC ADJUSTMENT	Delay before the leveller is lowering.
AUTOMATIC RAISE	The dock leveller is raised.
AUTOMATIC FOLD OUT	The lip is folded out.
AUTOMATIC AUTORETURN xxx	Automatic return cycle is active.

9.4 Operating mode Diagnosis

DISPLAY	Meaning	Status
STOP CHAIN	Stop circuit, Emergency Stop	ON: circuit closed OFF: interrupted (fault)
WHEEL BLOCK	Wheel block	ON: activated OFF: not activated
INTERLOCK	Interlock Door - leveller	ON: activated OFF: not activated
HOME LS	Limit switch dock leveller	OFF: activated ON: not activated
ACKNOWLEDGE	Acknowledged Traffic lights	ON: activated OFF: not activated
VEHICLE	Vehicle Sensor	ON: activated OFF: not activated
LIP-FORWARD	Push button Lip forward	ON: activated OFF: not activated
LIP-BACK	Push button Lip back	ON: activated OFF: not activated
RAISE	Push button dock up	ON: activated OFF: not activated
AR	Push button automatic return (AR)	ON: activated OFF: not activated
DROP	Push button drop (Option)	ON: activated OFF: not activated
CYCLE	cycle counter	Displays number of leveller cycles

9.5 Operating mode INPUT

Function	Description	Setting options	Factory setting																																																																																																																		
DEUTSCH	Select the menu language	DEUTSCH, ENGLISH, NEDERLANDS	DEUTSCH																																																																																																																		
Valve version	<p>1: 1 Valve standard</p> <table border="1"> <thead> <tr> <th colspan="2">1 Valve</th> <th colspan="2">standard</th> <th colspan="2">stop</th> </tr> <tr> <th>Function</th> <th>Contactor</th> <th>Y1</th> <th>Y1</th> <th>Y1</th> <th>Y1</th> </tr> </thead> <tbody> <tr> <td>Raise</td> <td>1</td> <td></td> <td>1</td> <td>1</td> <td></td> </tr> <tr> <td>Lower</td> <td>0</td> <td></td> <td>1</td> <td>1</td> <td></td> </tr> <tr> <td>Floating mode</td> <td>0</td> <td></td> <td>1</td> <td>1</td> <td></td> </tr> <tr> <td>Emergency mode</td> <td>0</td> <td></td> <td>0</td> <td>0</td> <td></td> </tr> </tbody> </table> <p>2: 1 Valve special</p> <table border="1"> <thead> <tr> <th colspan="2">1 Valve</th> <th colspan="2">special</th> <th colspan="2">stop</th> </tr> <tr> <th>Function</th> <th>Contactor</th> <th>Y1</th> <th>Y1</th> <th>Y1</th> <th>Y1</th> </tr> </thead> <tbody> <tr> <td>Raise</td> <td>1</td> <td></td> <td>0</td> <td>0</td> <td></td> </tr> <tr> <td>Lower</td> <td>0</td> <td></td> <td>1</td> <td>1</td> <td></td> </tr> <tr> <td>Floating mode</td> <td>0</td> <td></td> <td>1</td> <td>1</td> <td></td> </tr> <tr> <td>Emergency mode</td> <td>0</td> <td></td> <td>0</td> <td>0</td> <td></td> </tr> </tbody> </table> <p>3: 2 Valve special</p> <table border="1"> <thead> <tr> <th colspan="2">2 Valve</th> <th colspan="4">special</th> </tr> <tr> <th>Function</th> <th>Contactor</th> <th>Y1</th> <th>Y1</th> <th>Y2</th> <th>Y2</th> </tr> </thead> <tbody> <tr> <td>Raise</td> <td>1</td> <td>1</td> <td>0</td> <td>0</td> <td></td> </tr> <tr> <td>After Y1 time has elapsed</td> <td>1</td> <td>0</td> <td>0</td> <td>0</td> <td></td> </tr> <tr> <td>Lower</td> <td>0</td> <td>0</td> <td>1</td> <td>1</td> <td></td> </tr> <tr> <td>Floating mode</td> <td>0</td> <td>0</td> <td>1</td> <td>1</td> <td></td> </tr> <tr> <td>Emergency mode</td> <td>0</td> <td>0</td> <td>0</td> <td>0</td> <td></td> </tr> </tbody> </table>	1 Valve		standard		stop		Function	Contactor	Y1	Y1	Y1	Y1	Raise	1		1	1		Lower	0		1	1		Floating mode	0		1	1		Emergency mode	0		0	0		1 Valve		special		stop		Function	Contactor	Y1	Y1	Y1	Y1	Raise	1		0	0		Lower	0		1	1		Floating mode	0		1	1		Emergency mode	0		0	0		2 Valve		special				Function	Contactor	Y1	Y1	Y2	Y2	Raise	1	1	0	0		After Y1 time has elapsed	1	0	0	0		Lower	0	0	1	1		Floating mode	0	0	1	1		Emergency mode	0	0	0	0		1 ... 3	1
1 Valve		standard		stop																																																																																																																	
Function	Contactor	Y1	Y1	Y1	Y1																																																																																																																
Raise	1		1	1																																																																																																																	
Lower	0		1	1																																																																																																																	
Floating mode	0		1	1																																																																																																																	
Emergency mode	0		0	0																																																																																																																	
1 Valve		special		stop																																																																																																																	
Function	Contactor	Y1	Y1	Y1	Y1																																																																																																																
Raise	1		0	0																																																																																																																	
Lower	0		1	1																																																																																																																	
Floating mode	0		1	1																																																																																																																	
Emergency mode	0		0	0																																																																																																																	
2 Valve		special																																																																																																																			
Function	Contactor	Y1	Y1	Y2	Y2																																																																																																																
Raise	1	1	0	0																																																																																																																	
After Y1 time has elapsed	1	0	0	0																																																																																																																	
Lower	0	0	1	1																																																																																																																	
Floating mode	0	0	1	1																																																																																																																	
Emergency mode	0	0	0	0																																																																																																																	
AR-RAISE 1	Initial time to raise the dock leveller during the AR function from the floating position.	0,5 ... 25 Sek.	1 Sek.																																																																																																																		
AR-DROP 1	Time to drop the dock leveler during AR function to ensure that the lip is folded in completely before dropping to home position.	1 ... 5 Sek.	5 Sek.																																																																																																																		
AR-RAISE 2	Second time to raise the dock leveller during AR function..	1 ... 20 Sek.	6 Sek.																																																																																																																		
AR-DROP 2	Time to drop the dock leveller into home position.	1 ... 20 Sek.	2 Sek.																																																																																																																		
TIME HYDR	Maximum running time of the hydraulic unit. The watchdog timing of individual movement serves for the avoidance of overload due to defect push buttons or defective limit switches.	0 ... 254 Sek.	50 Sek.																																																																																																																		
TRAFFIC LIGHT MOD	Traffic lights are MOD 1: no traffic lights MOD 2: OFF in position home MOD 3: ON in position home	MOD 1 ... MOD 3	MOD 3																																																																																																																		

Function	Description	Setting options	Factory setting
Horn/LIGHT	<p>MOD 1: Horn Produces warning signal, if for example the wheel block is removed during the loading.</p> <p>MOD 2: Fan The fan is necessary for the function shelter as well as the tubular drive. During the activation of Shelter, MOD 2 is pre-selected and cannot be changed.</p> <p>MOD 3: Dock loading light After reaching the loading position the light is switched on and remains on, as long as to the dock leveler returns to home position.</p> <p>MOD 4:</p>	MOD 1 ... MOD 4	MOD 1
AUTORETURN	<p>MOD 1: Autoreturn not active</p> <p>MOD 2: Autoreturn active</p> <p>MOD 3: = MOD 2</p> <p>MOD 4: = MOD 2</p>	MOD 1 ... MOD 4	MOD2
WHEEL BLOCK	<p>MOD1: Wheel block not active</p> <p>MOD2: Wheel block active, with actuation during loading procedure the red traffic lights are switched on and the horn signalizes this.</p> <p>MOD3: Wheel block active, with actuation during loading procedure, all buttons are blocked.</p>	MOD 1 ... MOD 3	MOD1
VEHICLE SENSOR	<p>MOD 1: vehicle sensor not active</p> <p>MOD2: Optical and acoustic vehicle detection. When a vehicle drives in front of the door and activates the vehicle sensor, this is signalized by red traffic lights and the horn. The dock leveller is released for operation.</p> <p>MOD3: Optical and acoustic vehicle detection. When a vehicle drives in front of the door and activates the vehicle sensor, this is signalized by red traffic lights and the horn. The door (stop contact) is released for operation.</p>	MOD 1 ... MOD 3	MOD1

Function	Description	Setting options	Factory setting
SHELTER	MOD1: not active MOD2: Controlled via the program. MOD3: Controlled via the selector switch. (see free input)	MOD1 ... MOD3	MOD 1
SHELTER TIME	The time defines the delay for the release of the door before the start of the loading procedure as well as for the release of the green traffic light outside after the loading procedure.	0 ... 255 Sec.	5 Sec.
RELEASE +/-	MOD 1: NC contact MOD 2: NO contact	MOD 1, MOD2	MOD1
RELEASE	MOD1: active, if the door interlock is interrupted during the loading procedure, the leveller remains in floating position, both traffic lights switch to red, the buttons are locked and hydraulic unit is switched off. MOD2: active, if the door interlock is interrupted during the loading procedure, the leveller remains in floating position, both traffic lights switch to red.	MOD1, MOD2	MOD1
FREE INPUT	MOD 1: not active MOD 2: Traffic light acknowledge MOD 3: safety fence MOD 4: Selector switch shelter MOD 5: only for telescopic lip	MOD1 ... MOD 5	MOD1
Current control threshold	The value of the current control represents the increased height of the current of the hydraulic unit with the impact into an end position. This parameter must be adapted to the respective unit. 0= off	0% ... 35 % in percent	20%
Time Base	With this parameter different speeds of the telescopic lip can be adapted when drawing in and driving out. A negative value must be selected, if the lip is faster drawn in than driven out.	- 50 % ... 50%	0%
Y1 Raise (Visible only when mode value = 3)	After the set time value 1 (Y1) will the dock leveller extend.	0,1 ... 25,0	0

10. Error messages and rectification

Error messages	Cause	Rectification
System does not respond	No mains power	Check mains power to control box
Leveller is not rising when the UP button is operated.	interlock door – leveller is activated	Check interlock contact
Leveller is not raising when the UP button is operated, although motor is running, the red LED is out	Connection of the hydraulic unit is wrong	Swap two phase wires of the hydraulic unit
Red LED ON	Fuse defectively or phase is missing or to rotary field of the mains supply is wrong	Check hydraulic unit, cabling and fuses

Error message Display / Option	Cause	Rectification
ERROR HY ZEIT	The programmed running time been exceeded	Check buttons and cabling. Re-programme the running time
ERROR ROT:FIELD	An incorrect rotating field is connected to terminal X1	Ensure that a clockwise rotating field is connected
EMERGENCY STOP	Emergency stop circle opened or voltage failure during undefined position	- check emergency stop circuit - use the button up and AR to bring the leveller into the initial position.
INTERLOCK	interlock door – leveller is activated	Check interlock contact

11 Technical Data

Mains supply	3~ 400VAC, 50 Hz, +/- 10% 3~ 230VAC, 50 Hz, +/- 10%
Fuse supply voltage F1-F3	3 x 3,15A T at 400VAC 3 x 5A T at 230 VAC
Mains fuses	10A K- characteristic
Control voltage	24 VDC max. 0,9 A
Fuse control voltage (F4)	Resettable fuse 1,6 A
Maximal loads Hydraulic unit	Max 2,2 KW 6 A
Valve	24 VDC +/- 10%, 0,6 A / 100%
Mounting	Vertical on the wall , min. height 100 cm
Housing dimensions	215 mm x 275 m x 190 mm
Ambient temperature	-10° C ... +55°C
Storage temperature	-20°C ... +85°C
Isolation class	IP 65
Weight	5,5 Kg

